

# Product Summary Sheet

# HV254 32-Channel High Voltage Amplifier Array

## Applications

- MEMS Driver (microelectromechanical systems)
- Piezoelectric Transducer Driver
- Optical Crosspoint Switches (using MEMS technology)

### Product Overview:

The HV254 is a 32-channel high voltage amplifier array integrated circuit. Each channel is configured as a noninverting amplifier. The outputs can swing up to 250V with a guaranteed slew rate of 3V/μs while driving a 100pF load. The amplifier has an internal closed loop gain of 34dB or 50V/V saving the user from having to use external gain setting resistors. A 5V signal applied to the input of an amplifier will therefore create an output voltage of 250V.

The HV254 operates on a 275V supply and two low voltage supplies, +/-5V. It is designed to operate on minimal power while still maintaining a slew rate of 3V/μs. To further reduce power consumption, high value gain setting resistors are used for the internal feedback path. An integrated diode is also included to help monitor die temperature.

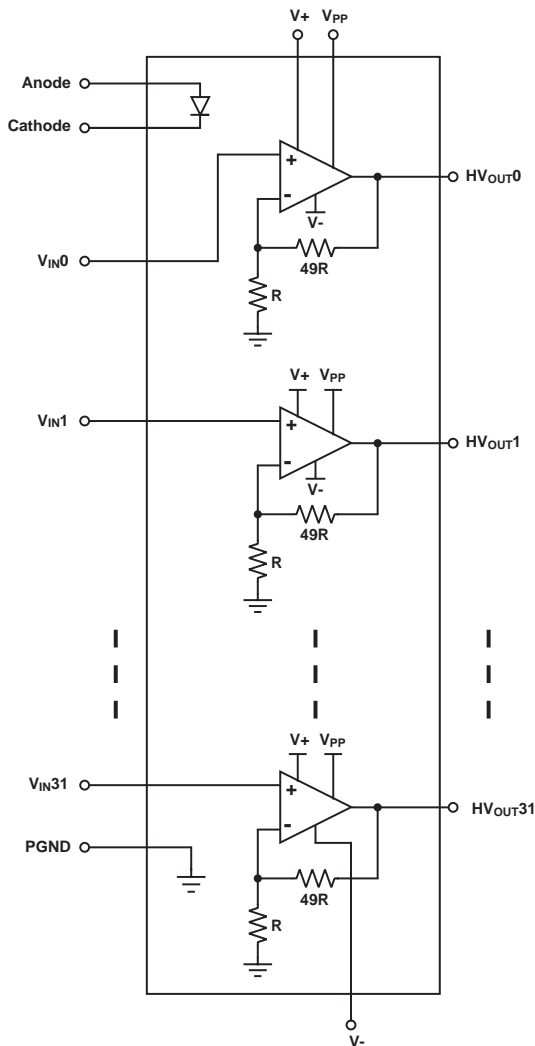

Block Diagram

### Features:

32 independent high voltage amplifiers

Output voltage up to 250V

3V/μs output slew rate

Integrated feedback resistors

High value internal feedback resistors

Very low operating current (typically 45μA per channel)

Integrated silicon diode for temperature sensing

### Benefits:

Saves board space

Provides adequate movement for an optical MEMS switch

Provides adequate switching time from one line to another

Saves board space. Reduces component count and simplifies board layout.

Minimizes power consumption and dissipation

Minimizes power consumption and dissipation

Allows for external temperature compensation or thermal protection

# HV254

## 32-Channel High Voltage Amplifier Array

### Electrical Specifications

<u>Device</u>	<u>Package</u>	<u># of Channels</u>	<u>Max. Output Voltage</u>	<u>Closed Loop Gain</u>
HV254FG	100 Lead MQFP	32	250V	50V/V
HV254X	Die Form	32	250V	50V/V

### Ordering Information / Availability

<u>Part Number</u>	<u>Datasheet</u>	<u>Samples</u>	<u>Demo Board</u>	<u>Lead Time</u>
HV254FG	HV254 Now	HV254FG Now	HV254DB1 11/15/02	4 - 5 weeks ARO

### Product Contact

If you have questions regarding the HV254 or would like to receive samples, contact Supertex Applications at:

Telephone: (800) 222-9883  
Fax: (408) 222-4895  
Email: [apps@supertex.com](mailto:apps@supertex.com)  
Web: [www.supertex.com](http://www.supertex.com)

Supertex Sales:

Contact your Supertex Area Sales Office