



## 32-Channel High Voltage Amplifier Array

### Features

- ❑ 32 independent high voltage amplifiers
- ❑ Output voltage up to 250V
- ❑ 3V/μs output slew rate
- ❑ Fixed gain of 50V/V
- ❑ High value internal feedback resistors
- ❑ Very low operating current (typically 45μA per channel)
- ❑ Integrated silicon diode for temperature sensing

### Application

- ❑ MEMS (microelectromechanical systems) driver
- ❑ Piezoelectric transducer driver
- ❑ Optical crosspoint switches (using MEMS technology)

### General Description

The Supertex HV254 is a 32-channel high voltage amplifier array integrated circuit. It operates on a 275V high voltage supply and two low voltage supplies: +5.0V and -5.0V. Each channel has its own input and output. An integrated diode is included to help monitor die temperature.

The input voltage can be from a dac with a voltage range of 0V to the low voltage supply, V+. The output of the HV254FG will swing from 7V to 250V. It cannot swing to ground. With the internal gain set at 50V/V, a minimum input signal of 140mV will still maintain linearity. Input voltages below 140mV can be applied without damage to the device. The amplifier, however, will be saturated. Typical output load is equivalent to a 125Mohm resistor in parallel with a 100pF capacitor. The outputs have a guaranteed slew rate of at least 3V/μs. The internal closed loop gain is set at a nominal value of 34.0dB (50V/V).

The HV254 is designed to operate with minimal power consumption while maintaining a guaranteed slew rate of 3V/μs. High value resistors are used for the gain setting to minimize current on the feedback path.

### Block Diagram

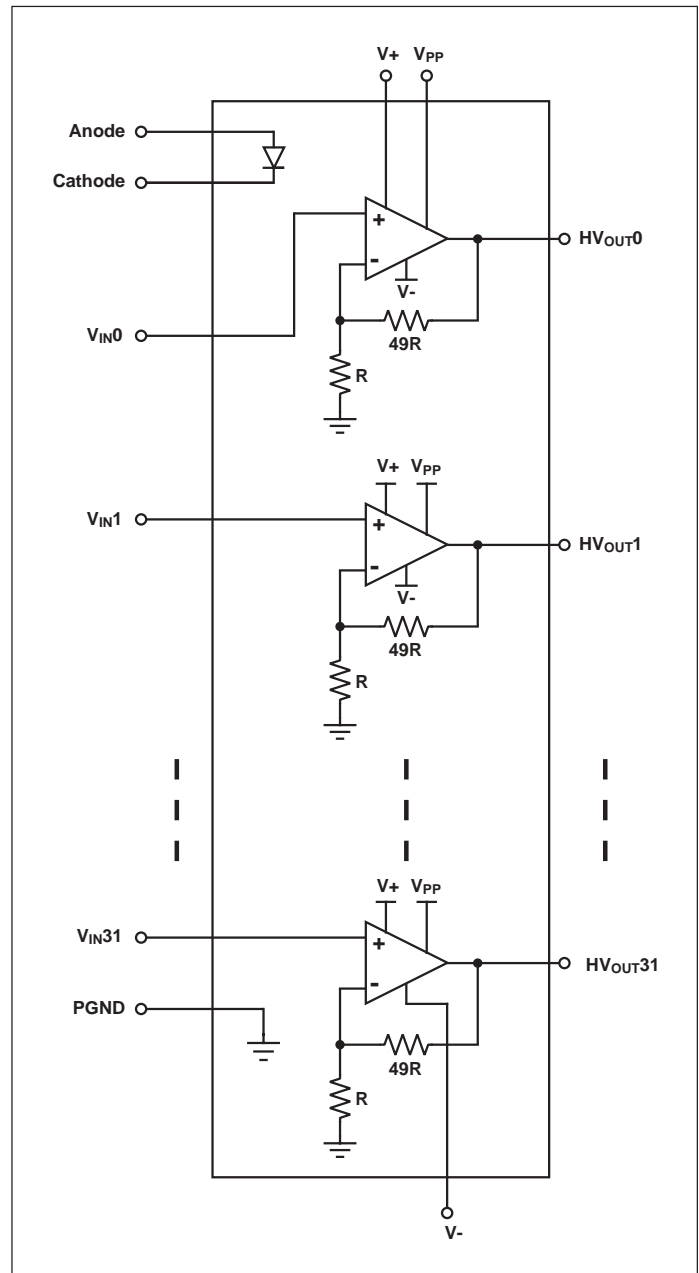

## Ordering Information

Device	Maximum Output Voltage	Package Options	
		100 Lead MQFP	Die
HV254	250V	HV254FG	HV254X

## Absolute Maximum Ratings\*

$V_{PP}$ , High voltage supply	275V
V+, Low voltage positive supply	7.0V
V-, Low voltage negative supply	-7.0V
$HV_{OUT}$ , Output voltage	0V to 275V
$V_{IN}$ , Analog input signal	0V to 5.0V
Storage temperature range	-65°C to 150°C
Maximum junction temperature	150°C

\* All voltages are referenced to device ground.

## Electrical Characteristics (Over operating conditions unless otherwise noted.)

Symbol	Parameter	Min	Typ	Max	Units	Conditions
--------	-----------	-----	-----	-----	-------	------------

### Operating Conditions

$V_{PP}$	High voltage positive supply	50		275	V	
V+	Low voltage positive supply	4.75	5.0	5.25	V	
V-	Low voltage negative supply	-4.75	-5.0	-5.25	V	
$I_{PP}$	$V_{PP}$ supply current	1.0		2.5	mA	$V_{PP}=275V$ , All inputs set at 140mV. Typically 45 $\mu$ A per channel
I+	V+ supply current			1.0	mA	V+ = 5.25V
I-	$V_{NN}$ supply current			-3.0	mA	V- = -5.25V
$T_A$	Ambient temperature range	-10		70	° C	
$T_J$	Junction temperature range	-10		TBD	° C	

### High Voltage Amplifier Output

$HV_{OUT}$	$HV_{OUT}$ voltage swing	7.0		250	V	$V_{PP} = 275V$ , Load=125M $\Omega$ //100pF
$V_{IN}$	Input Voltage Range	0.14		V+	V	
$HV_{OS}$	$HV_{OUT}$ DC offset		$\pm 1.5$	$\pm 1.52$	V	$V_{PP} = 275V$ . 30mV input offset
SR	$HV_{OUT}$ slew rate	3.0			V/ $\mu$ s	$V_{PP} = 275V$ , Load = 125M $\Omega$ //100pF
$R_{FB}$	Feedback impedance	8	12		M $\Omega$	
$A_V$	Closed loop gain	47.5	50.0	52.5	V/V	
BW	$HV_{OUT}$ -3dB channel bandwidth	5.0			KHz	$V_{PP} = 275V$
$C_{LOAD}$	$HV_{OUT}$ capacitive load	0		100	pF	
	Stability (max drift)			500	mV	Measured at $HV_{OUT}$

# Diode

Symbol	Parameter	Min	Typ	Max	Units	Conditions
PIV	Peak inverse voltage			5.0	V	cathode to anode
$V_F$	Forward diode drop			0.8	V	$I_f=2.0\text{mA}$ , anode to cathode
$I_F$	Forward diode current			2.0	mA	anode to cathode
$T_C$	$V_F$ temperature coefficient		TBD		mV/° C	anode to cathode

## Power Up/Down Sequence

The device can be damaged due to improper power up / down sequence. To prevent damage, please follow the acceptable power up /down sequences and add two external diodes as shown in the diagram below. The first diode is a high voltage diode across  $V_{pp}$  and  $V+$  where the anode of the diode is connected to  $V+$  and the cathode of the diode is connected to  $V_{pp}$ . Any low current high voltage diode such as a 1N4004 will be adequate. The second diode is a schottky diode across  $V-$  and PGND where the anode of the schottky diode is connected to  $V-$  and the cathode is connected to PGND. Any low current schottky diode such as a 1N5817 will be adequate.

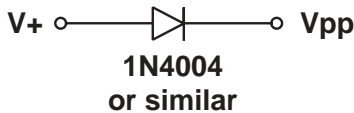

### Acceptable Power Up Sequences

- |             |         |             |                   |
|-------------|---------|-------------|-------------------|
| 1) $V_{pp}$ | 2) $V-$ | 3) $V+$     | 4) Inputs & Anode |
| 1) $V+$     | 2) $V-$ | 3) $V_{pp}$ | 4) Inputs & Anode |

### Acceptable Power Down Sequences

- |                   |             |         |             |
|-------------------|-------------|---------|-------------|
| 1) Inputs & Anode | 2) $V_{pp}$ | 3) $V+$ | 4) $V-$     |
| 1) Inputs & Anode | 2) $V+$     | 3) $V-$ | 4) $V_{pp}$ |

## Pin Description

$V_{pp}$	High voltage positive supply.
$V+$	Analog low voltage positive supply.
$V-$	Analog low voltage negative supply.
PGND	Device ground.
Anode	Anode side of a low voltage silicon diode that can be used to monitor die temperature.
Cathode	Cathode side of a low voltage silicon diode that can be used to monitor die temperature.
$V_{IN}0$ to $V_{IN}31$	Amplifier inputs.
$HV_{OUT}0$ to $HV_{OUT}31$	Amplifier outputs.

# Pin Configuration

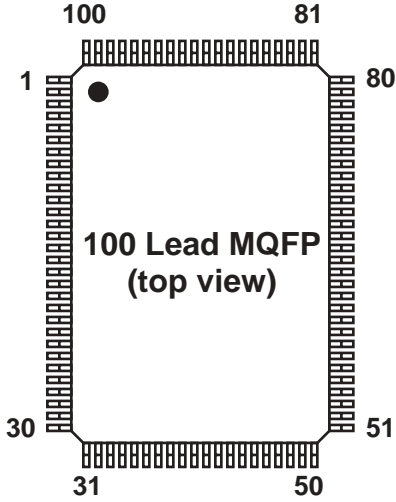

# Pin Configuration

Pin #	Function	Pin #	Function	Pin #	Function	Pin #	Function
1	HV <sub>OUT</sub> 29	26	HV <sub>OUT</sub> 4	51	V <sub>IN</sub> 2	76	V <sub>IN</sub> 27
2	HV <sub>OUT</sub> 28	27	HV <sub>OUT</sub> 3	52	V <sub>IN</sub> 3	77	V <sub>IN</sub> 28
3	HV <sub>OUT</sub> 27	28	HV <sub>OUT</sub> 2	53	V <sub>IN</sub> 4	78	V <sub>IN</sub> 29
4	HV <sub>OUT</sub> 26	29	HV <sub>OUT</sub> 1	54	V <sub>IN</sub> 5	79	V <sub>IN</sub> 30
5	HV <sub>OUT</sub> 25	30	HV <sub>OUT</sub> 0	55	V <sub>IN</sub> 6	80	V <sub>IN</sub> 31
6	HV <sub>OUT</sub> 24	31	NC	56	V <sub>IN</sub> 7	81	PGND
7	HV <sub>OUT</sub> 23	32	NC	57	V <sub>IN</sub> 8	82	NC
8	HV <sub>OUT</sub> 22	33	NC	58	V <sub>IN</sub> 9	83	NC
9	HV <sub>OUT</sub> 21	34	NC	59	V <sub>IN</sub> 10	84	NC
10	HV <sub>OUT</sub> 20	35	NC	60	V <sub>IN</sub> 11	85	NC
11	HV <sub>OUT</sub> 19	36	V <sub>PP</sub>	61	V <sub>IN</sub> 12	86	NC
12	HV <sub>OUT</sub> 18	37	V <sub>PP</sub>	62	V <sub>IN</sub> 13	87	NC
13	HV <sub>OUT</sub> 17	38	NC	63	V <sub>IN</sub> 14	88	NC
14	HV <sub>OUT</sub> 16	39*	I <sub>bias</sub>	64	V <sub>IN</sub> 15	89	NC
15	HV <sub>OUT</sub> 15	40	NC	65	V <sub>IN</sub> 16	90	NC
16	HV <sub>OUT</sub> 14	41	V-	66	V <sub>IN</sub> 17	91	NC
17	HV <sub>OUT</sub> 13	42	V-	67	V <sub>IN</sub> 18	92	NC
18	HV <sub>OUT</sub> 12	43	Anode	68	V <sub>IN</sub> 19	93	NC
19	HV <sub>OUT</sub> 11	44	Cathode	69	V <sub>IN</sub> 20	94	NC
20	HV <sub>OUT</sub> 10	45	V+	70	V <sub>IN</sub> 21	95	NC
21	HV <sub>OUT</sub> 9	46	V+	71	V <sub>IN</sub> 22	96	NC
22	HV <sub>OUT</sub> 8	47	NC	72	V <sub>IN</sub> 23	97	NC
23	HV <sub>OUT</sub> 7	48	PGND	73	V <sub>IN</sub> 24	98	NC
24	HV <sub>OUT</sub> 6	49	V <sub>IN</sub> 0	74	V <sub>IN</sub> 25	99	HV <sub>OUT</sub> 31
25	HV <sub>OUT</sub> 5	50	V <sub>IN</sub> 1	75	V <sub>IN</sub> 26	100	HV <sub>OUT</sub> 30

\* For internal testing only. Leave floating.  
NC=No Connect.

# Pad Configuration (Not Drawn to Scale)

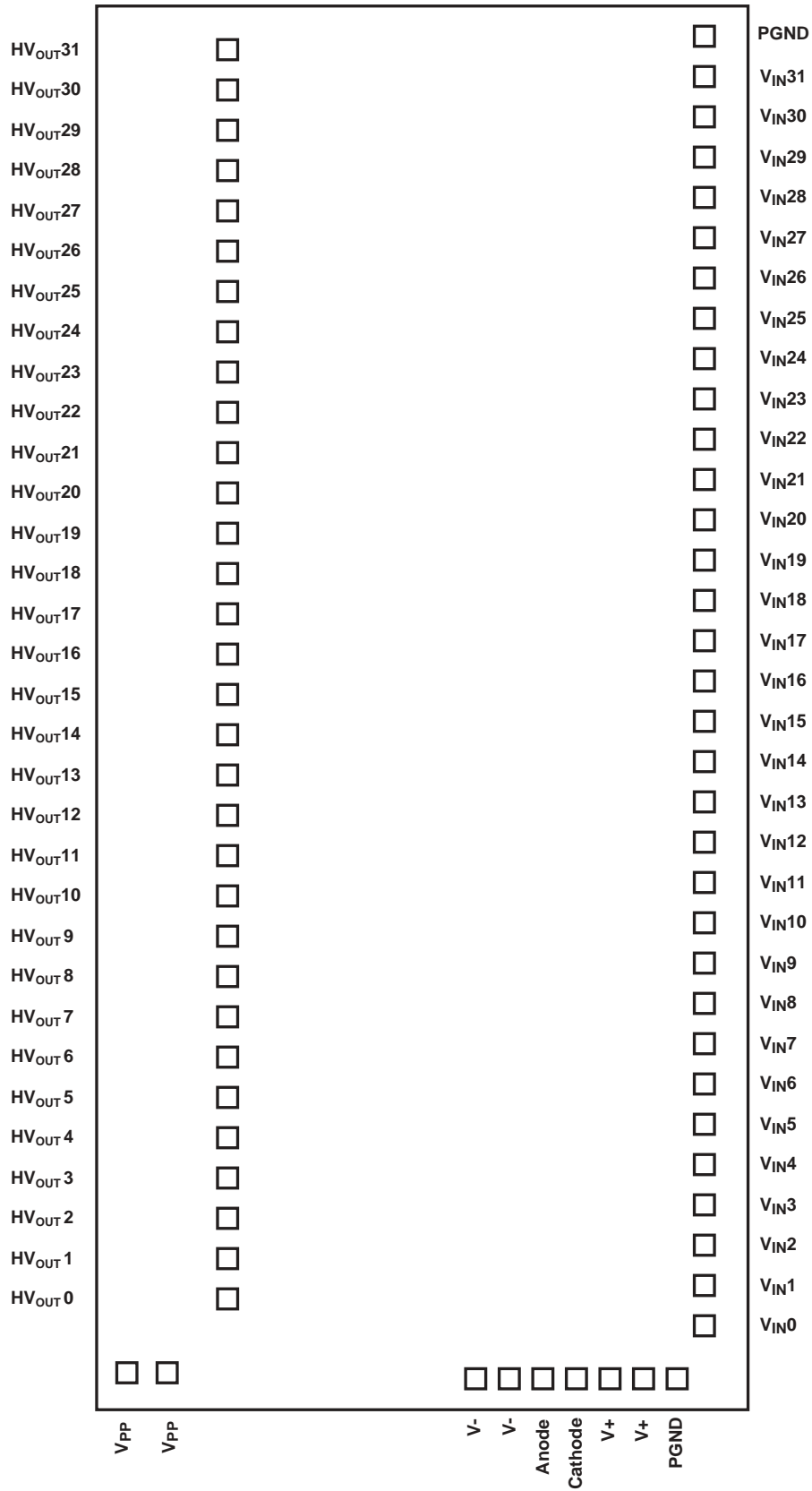

Die Size=4800 $\mu$ m X 11180 $\mu$ m (including scribes)

Center of the die is 0,0.

Coordinates for the four corners of the chip (not including scribe):

X ( $\mu$ m)	Y ( $\mu$ m)
-2402	5492
-2402	-5492
2335	5492
2335	-5492

**Notes:**

- 1) The two PGND pads are not electrically connected.
- 2) The two  $V_{PP}$  pads, V+ pads, and V- pads are electrically connected.
- 3) Backside potential is  $V_{PP}$ . Leave floating or connect to  $V_{PP}$ .
- 4) Anode and Cathode are connected to the P and N terminals (respectively) of a silicon diode which can be used to measure temperature.

## Pad Description:

$V_{PP}$	High voltage positive supply. Two $V_{PP}$ pads.
V+	Low voltage positive supply. Two V+ pads.
V-	Low voltage negative supply. Two V- pads.
$V_{IN0}$ to $V_{IN31}$	Amplifier inputs.
$HV_{OUT0}$ to $HV_{OUT31}$	Amplifier outputs.
PGND	Power ground. Two PGND pads. Need to be externally connected together.
Anode	Anode side of diode.
Cathode	Cathode side of diode.

## Pad Coordinates

Pad Name	X ( $\mu$ m)	Y ( $\mu$ m)
HV <sub>OUT</sub> 31	-1447.5	5244
HV <sub>OUT</sub> 30	-1447.5	4926.5
HV <sub>OUT</sub> 29	-1447.5	4609
HV <sub>OUT</sub> 28	-1447.5	4291.5
HV <sub>OUT</sub> 27	-1447.5	3974
HV <sub>OUT</sub> 26	-1447.5	3656.5
HV <sub>OUT</sub> 25	-1447.5	3339
HV <sub>OUT</sub> 24	-1447.5	3021.5
HV <sub>OUT</sub> 23	-1447.5	2704
HV <sub>OUT</sub> 22	-1447.5	2386.5
HV <sub>OUT</sub> 21	-1447.5	2069
HV <sub>OUT</sub> 20	-1447.5	1751.5
HV <sub>OUT</sub> 19	-1447.5	1434
HV <sub>OUT</sub> 18	-1447.5	1116.5
HV <sub>OUT</sub> 17	-1447.5	799
HV <sub>OUT</sub> 16	-1447.5	481.5
HV <sub>OUT</sub> 15	-1447.5	164
HV <sub>OUT</sub> 14	-1447.5	-153.5
HV <sub>OUT</sub> 13	-1447.5	-471
HV <sub>OUT</sub> 12	-1447.5	-788.5
HV <sub>OUT</sub> 11	-1447.5	-1106
HV <sub>OUT</sub> 10	-1447.5	-1423.5
HV <sub>OUT</sub> 9	-1447.5	-1741
HV <sub>OUT</sub> 8	-1447.5	-2058.5
HV <sub>OUT</sub> 7	-1447.5	-2376

Pad Name	X ( $\mu$ m)	Y ( $\mu$ m)
HV <sub>OUT</sub> 6	-1447.5	-2693.5
HV <sub>OUT</sub> 5	-1447.5	-3011
HV <sub>OUT</sub> 4	-1447.5	-3328.5
HV <sub>OUT</sub> 3	-1447.5	-3646
HV <sub>OUT</sub> 2	-1447.5	-3963.5
HV <sub>OUT</sub> 1	-1447.5	-4281
HV <sub>OUT</sub> 0	-1447.5	-4598.5
$V_{PP}$	-2057	-4985
$V_{PP}$	-1897	-4985
V-	1030.5	-5018
V-	1190.5	-5018
Anode	1350.5	-5018
Cathode	1550.5	-5018
V+	1710.5	-5018
V+	1870.5	-5018
Pgnd	2034.5	-5018
$V_{IN0}$	2156.5	-4725
$V_{IN1}$	2156.5	-4411
$V_{IN2}$	2156.5	-4097
$V_{IN3}$	2156.5	-3783
$V_{IN4}$	2156.5	-3469
$V_{IN5}$	2156.5	-3155
$V_{IN6}$	2156.5	-2841
$V_{IN7}$	2156.5	-2527
$V_{IN8}$	2156.5	-2213

Pad Name	X ( $\mu$ m)	Y ( $\mu$ m)
$V_{IN9}$	2156.5	-1899
$V_{IN10}$	2156.5	-1585
$V_{IN11}$	2156.5	-1271
$V_{IN12}$	2156.5	-957
$V_{IN13}$	2156.5	-643
$V_{IN14}$	2156.5	-329
$V_{IN15}$	2156.5	-15
$V_{IN16}$	2156.5	299
$V_{IN17}$	2156.5	613
$V_{IN18}$	2156.5	927
$V_{IN19}$	2156.5	1241
$V_{IN20}$	2156.5	1555
$V_{IN21}$	2156.5	1869
$V_{IN22}$	2156.5	2183
$V_{IN23}$	2156.5	2497
$V_{IN24}$	2156.5	2811
$V_{IN25}$	2156.5	3125
$V_{IN26}$	2156.5	3439
$V_{IN27}$	2156.5	3753
$V_{IN28}$	2156.5	4067
$V_{IN29}$	2156.5	4381
$V_{IN30}$	2156.5	4695
$V_{IN31}$	2156.5	5009
Pgnd	2156.5	5315.5

07/24/03rev.6e