

P145010E PHOTOELECTRIC SMOKE DETECTOR IC

1. Product description

1.1 Basic function:

P145010E is a CMOS LSI used for smoke detection. Ultra-low power analog and digital circuits are contained in it. Combined with an IR photoelectric chamber, this IC is used to detect smoke through receiving light scattered by tiny smoke particles going into the chamber. When smoke is detected, A burst of alarm sounds are generated by an external piezoelectric buzzer driven by the push-pull output of this IC.

1.2 Applications:

Smoke detection system.

2. Features:

Power supply range: 6V ~ 12V

Average supply current: 12uA

Operating temperature range: -10 ~ 60°C

Ideal for battery powered applications.

3. Block diagram

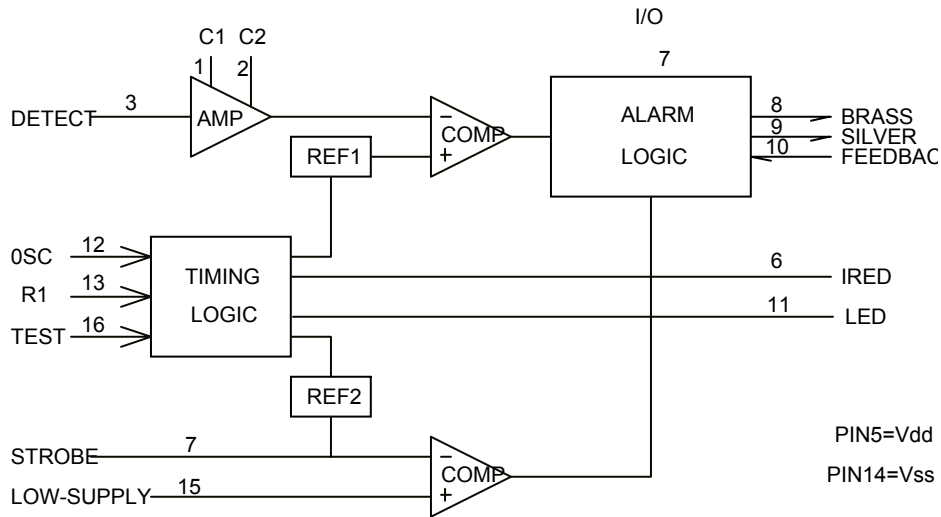

4. Pin assignment

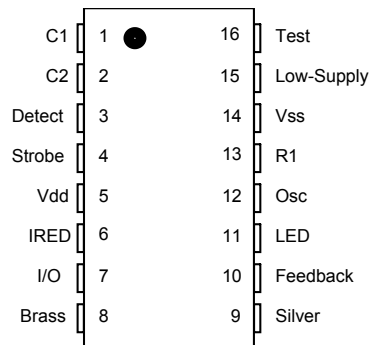

5. Pin description

Pin No.	Symbol	Input/output	Functions	
1, 2	C1, C2		External capacitor connection	By connecting external capacitor, a voltage feedback amplifier is formed. The gain of it is determined by capacitor's value.
3	DETECT	I	Detecting input	Connect a photodiode to supply a signal to the internal comparator.
4	STROBE	0	Strobe	A strobe voltage output, referenced to V_{DD} . When output = $V_{DD} - 5V$, it enables other internal circuits.
5, 14	V_{DD} , GND		Power supply	To supply the power
6	IREDD	0	Output signal	To output pulse drive signal for external NPN transistor which drives a IR photodiode.
7	I/O		Input/output	It can be used to connect up to 40 detectors to make auxiliary alarm, remote alarm, auto-dialer...
8, 9	BRASS, SILVER	0	Push-pull driver's output	Push-pull driver outputs signal to drive external buzzer to alarm, and to show various operation states.
10	FEEDBACK	I	Feedback terminal	To feed 'silver' signal back to the push-pull output driver circuit's input
11	LED	0	Output signal	It is an open drain output, can drive LED directly. The LED can tell the detector's various operation states.
12	OSC	I	Oscillator's input	Connected to external R and C, which determine the internal oscillator's frequency.
13	R1		External R and C connecting terminal	Connected to external R and C, which determine the output pulse period of IREDD.
15	LOW-SUPPLY	I	Low voltage detecting input	It connected to external resistor divider between V_{DD} and LED to get a low supply alarm threshold voltage

16	TEST	I	Test terminal	This pin is normally low by an internal pull-down device. When it is set high, the IC enters into a simulated-smoke condition. When floating, this pin comes back to V _{SS} (low) by pull-down device.
----	------	---	---------------	---

6. Function of this IC:

6.1. The variable gain photoelectric amplifier is directly connected to IR detector (photodiode). The amplifier's gain is determined by external capacitors C1 and C2. During standby, the amplifier's gain is at minimum. Under smoke condition, the amplifier's gain is at medium. Entering into test condition, the amplifier's gain is at maximum. Additionally, under standby state, if the special supervisory circuit is activated to check the chamber's sensitivity, the amplifier's gain is also at its maximum.

6.2. Using V_{SS} as its reference, the I/O pin can be used to connect up to 40 units together. When I/O pin is used as an input, its on-chip pull-down resistor can prevent noise from entering into the unit. Under smoke status, the unit activates I/O driver to send a signal to its interconnected units to activate remote alarm.

6.3. Display method: LED (connected to LED pin) flashing combined with alarm sound, indicates a LOCAL SMOKE condition. Only pulsating alarm sound without LED flashing indicates a REMOTE SMOKE condition.

7. Specifications:

7.1. Absolute maximum ratings (V_{SS} as reference)

Symbol	Parameter	Limits	Units
V _{DD}	Supply voltage	-0.5 ~ +12	
V _{IN} DC input voltage	C1, C2, Detect	-0.25 ~ V _{DD} +0.25	V
	OSC, low-supply trip	-0.25 ~ V _{DD} +0.25	
	I/O	-0.25 ~ V _{DD} +0.25	
	Feedback	-15 ~ +15	
	Test	-1.0 ~ V _{DD} +0.25	
I _{IN}	DC input current	±10	mA
I _{OUT}	DC output current	±25	mA
I _{DD}	Supply current	+25/-150	mA
PD	Power dissipation in still air, 5Sec	1200	mW
	Continuous	350	
TSTG	Storage temperature	-55 ~ 125	°C
TL	Soldering temperature	260	°C

7.2 DC Electrical characteristics (T_a=25 °C, V_{SS} as reference, unless otherwise indicated)

Symbol	Parameters		Test condition	V _{DD}	Min.	Max.	Unit
V _{DD}	Power supply voltage range			--	6.0	12	V
V _{TH}	Supply threshold voltage, Low supply alarm voltage		Low supply trip voltage V _{IN} = V _{DD} /3		6.5	7.8	V
I _{DD}	Average supply current		Standby, (See sample figure)	12	--	12	uA
i _{DD}	Supply peak current		Strobe on, IRED off (See sample figure)	12	--	2.0	mA
V _{IL}	Low level input voltage, I/O Feedback Test			9.0 9.0 9.0		1.5 2.7 7.0	V
V _{IH}	High level input voltage I/O Feedback Test			9.0 9.0 9.0	3.2 6.3 8.5		V
I _{IN}	Input current OSC, Detect Low supply trip Feedback		V _{IN} = V _{SS} or V _{DD} V _{IN} = V _{SS} or V _{DD} V _{IN} = V _{SS} or V _{DD}	12 12 12		±100 ±100 ±100	nA
I _{IL}	Low level input current TEST		V _{IN} = V _{SS}	12		-1	uA
I _{IH}	Pull-down current Test I/O		V _{IN} = V _{DD} No local smoke, V _{IN} = V _{DD} No local smoke, V _{IN} = 17V	9.0 9.0 12	0.5 25 --	10 100 140	uA
V _{OL}	Low level output voltage, LED Silver, Brass		I _{OUT} = 10mA I _{OUT} = 16mA	6.5 6.5		0.6 1.0	V
V _{OH}	High level output voltage Silver, Brass		I _{OUT} = -16mA	6.5	5.5	-	V
V _{OUT}	Output voltage (See pin description)	Strobe	Inactive, I _{OUT} = -1uA Active, I _{OUT} = 100uA to 500uA (load regulation)	- 9.0	V _{DD} -0.1 V _{DD} -4.4	V _{DD} -5.6	V
		IRED	Inactive, I _{OUT} =-1uA Active, I _{OUT} =6uA (load regulation)	- 9.0	- 2.25	0.1 3.75	

I _{OH}	High-level output current, I/O	Local smoke, V _{OUT} =4.5V	6.5	-4	--	mA
		Local smoke, V _{OUT} = V _{SS} (short-circuit current)	12	--	-16	
I _{OZ}	Output off-state leak current, LED	V _{OUT} = V _{SS} or V _{DD}	12	-	±1	uA
V _{IC}	Common-mode voltage range C1, C2, Detect	Local smoke, Pushbutton test or chamber sensitivity test	--	V _{DD} -4	V _{DD} -2	V
V _{REF}	Internal reference voltage of smoke comparator	Local smoke, pushbutton test or chamber sensitivity test	--	V _{DD} -3.08	V _{DD} -3.92	V

7.3 AC ELECTRICAL CHARACTERISTICS

(T_A = 25°C, V_{DD} = 9.0 V, Component Values: R1 = 100.0 K, C3 = 1500.0 pF, R2 = 10.0 MΩ)

Symbol	Parameters	Test condition	Clocks	Min	Max	Unit
1/f _{osc}	Oscillator Period*	Free-Running Sawtooth Measured at Pin 12	1	9.5	11.5	ms
t _{LED}	LED Pulse Period	No Local Smoke, and No Remote Smoke	4096	38.9	47.1	s
		Remote Smoke, but No Local Smoke	-	None		
		Local Smoke or Pushbutton Test	64	0.60	0.74	
t _{w(LED)} , t _{w(stb)}	LED Pulse Width and Strobe Pulse Width		1	9.5	11.5	ms
t _{IRED}	IRED Pulse Period	Smoke Test	1024	9.67	11.83	s
		Chamber Sensitivity Test, without Local Smoke	4096	38.9	47.1	
		Pushbutton Test	32	0.302	0.370	
t _{w(IRED)}	IRED Pulse Width		Tf*	94	116	us
t _r	IRED Rise Time		-	-	30	us
t _f	IRED Fail Time		-	-	200	us
t _{mod}	Silver and Brass Modulation Period	Local or Remote Smoke	-	297	363	ms
t _{on} /t _{mod}	Silver and Brass Duty Cycle	Local or Remote Smoke	-	73	77	%

t_{CH}	Silver and Brass Chirp Pulse Period	Low Supply or Degraded Chamber Sensitivity	4096	38.9	47.1	s
$t_{w(CH)}$	Silver and Brass Chirp Pulse Width	Low Supply or Degraded Chamber Sensitivity	1	9.5	11.5	ms
t_{RR}	Rising Edge on I/O to Smoke Alarm Response Time	Remote Smoke, No Local Smoke	-	-	800	ms
t_{stb}	Strobe Out Pulse Period	Smoke Test	1024	9.67	11.83	s
		Chamber Sensitivity Test, without Local Smoke	4096	38.9	47.1	
		Low Supply Test, without Local Smoke	4096	38.9	47.1	
		Pushbutton Test	-	0.302	0.370	

*Oscillator period T ($= T_r + T_f$) is determined by the external components $R1$, $R2$, and $C3$ where $T_r = (0.6931) R2 * C3$ and $T_f = (0.6931) R1 * C3$.

The other timing characteristics are some multiple of the oscillator timing as shown in the table.

8. Typical Application

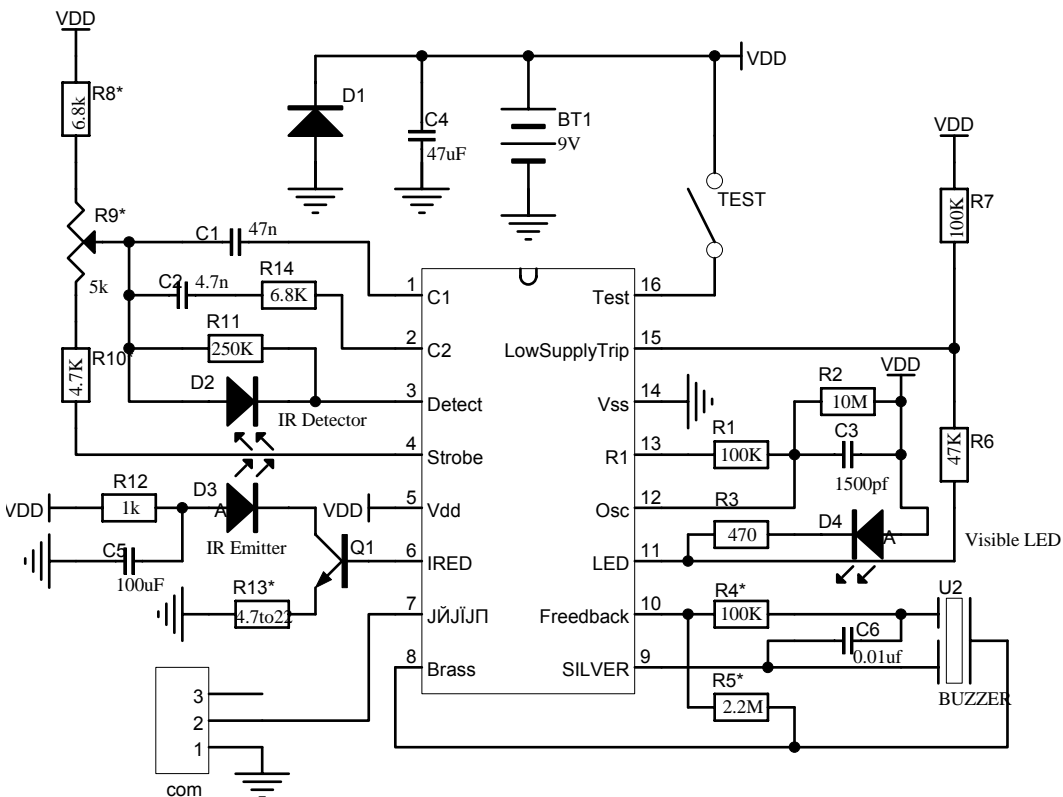

9. Calibration:

To enter calibration mode, pin16 (TEST) must be below VSS, pulling more than 100uA continuously out of the pin for at least one OSC cycle. To exit this mode, the TEST pin is floated at least one OSC cycle.

Table. Configuration of pins in the calibration mode

Description	PIN	Comments
I/O	7	Forcing this pin = V_{DD} , places photo amp' s output on pin2 when pin15= V_{DD} , or on pin1 when pin15= V_{SS} .
Low-supply	15	Low: normal gain of photo amplifier on pin1. High: supervisory gain on pin2.
Feedback	10	When pin15=low, driving it high enables gain with a hysteresis in the photo amp.
OSC	12	It equals to internal clock.
Silver	9	This pin becomes smoke comparator' s output. Positive pulses indicate that smoke has been detected. A static low level indicates no smoke.
Brass	8	This pin becomes the smoke integrator' s output. Static high level means two consecutive smoke detections. Static low level means two no-detections.