



TSM108

AUTOMOTIVE SWITCH MODE VOLTAGE AND CURRENT CONTROLLER

PRELIMINARY DATA

- CURRENT MEASUREMENT ON OUTPUT POSITIVE LINE
- CONSTANT VOLTAGE MODE CONTROL
- CONSTANT CURRENT MODE CONTROL
- PRECISION VOLTAGE AND CURRENT CONTROL LOOPS
- ADJUSTABLE SWITCHING FREQUENCY
- ADJUSTABLE OVER VOLTAGE LOCKOUT
- ADJUSTABLE UNDER VOLTAGE LOCKOUT
- STANDBY MODE (LOW QUIESCENT CURRENT)
- SUSTAINS 60V
- MINIMAL EXTERNAL COMPONENTS COUNT
- DRIVING ABILITY FOR EITHER P-MOSFET OR PNP TRANSISTORS

DESCRIPTION

TSM108 is a P-channel MOSFET controller which ensures constant voltage and constant current in Switching Mode Power Supply (step down) like in automotive battery charging applications.

TSM108 can easily be configured for very wide voltage and current needs.

TSM108 is built in rugged BCD technology and includes a PWM generator, Voltage and Current control loops, a precision Voltage Reference, and a PMosfet Gate Drive output. TSM108 can sustain 60V on Vcc, and therefore meet the standard Load Dump requirements in the Automotive field.

TSM108 includes security functions which lock the PMosfet in OFF state: OVLO (Over Voltage Lock-Out) and UVLO (Under Voltage LockOut). The PMosfet Gate is also protected from overvoltage drive thanks to a 12V clamping protection circuit.

TSM108 includes a standby feature which allows very low quiescent current when activated, as well as safe P-Mosfet Off state.

TSM108 is suitable for car environment accessories, as well as numerous other DC/DC step down regulation.

APPLICATION DIAGRAM

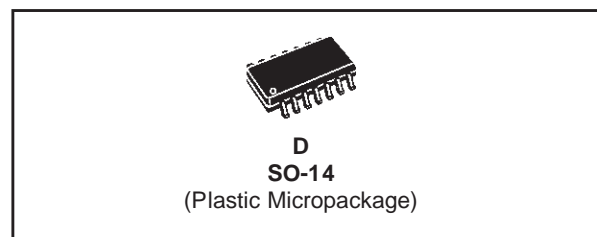
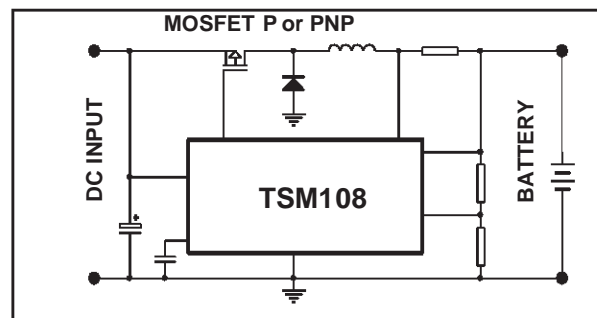

ORDER CODE

Part Number	Temperature Range	Package
		D
TSM108I	-40°, +125°C	•

D = Small Outline Package (SO) - also available in Tape & Reel (DT)

PIN CONNECTIONS (top view)

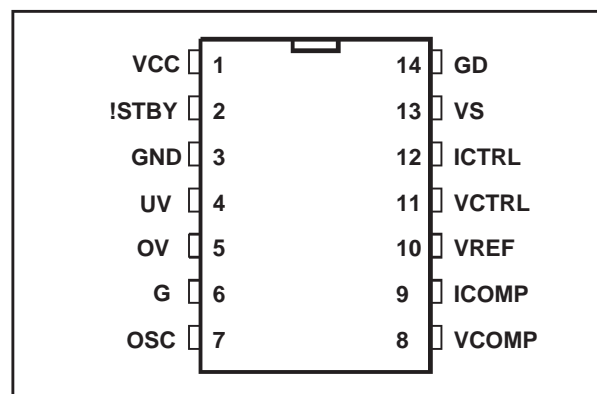

TSM108

PIN DESCRIPTION

Name	Pin	Type	Description
V _{CC}	1	Power Supply	Power Supply Line of the Device - Source of the P-MOSFET
GND	3	Power Ground	0V Reference for all Voltages
GD	14	Gate Drive	Gate Drive Pin of the P-MOSFET - Middle Point of the MOSET Push Pull Output Stage
V _{ref}	10	Output	Voltage Reference Output
V _s	13	HZ Input	Voltage Sense Resistor Input
I _{ctrl}	12	HZ Input	Current Regulation Input
V _{ctrl}	11	HZ Input	Voltage Regulation Input
V _{comp}	8	Output	Compensation pin - Output of Voltage Control Op-Amp
I _{comp}	9	Output	Compensation pin - Output of Current Control Op-Amp
OSC	7	Input	Oscillator Frequency Set Capacitor
!Stby	2	Input	Standby Command (Command = 0V ==> Device Standby)
UV	4	I/O	Programmable Under Voltage LockOut. The middle point of the integrated resistor bridge is accessible. Preset value is 8V min.
OV	5	I/O	Programmable Over Voltage LockOut. The middle point of the integrated resistor bridge is accessible. Preset value is 33V max.
G	6	Test Pin	Internally Connected to Ground

ABSOLUTE MAXIMUM RATINGS

Symbol	Parameter	Value	Unit
V _{CC}	Supply Voltage - Transient conditions (400ms max.)	60	v
T _j	Maximum Junction Temperature	150	°C
R _{thja}	Thermal Resistance Junction to Ambient (SO package)	130	°C/W
T _{amb}	Ambiant Temperature	-55 to +125	°C

OPERATING CONDITIONS

Symbol	Parameter	Value	Unit
V _{CC}	Supply Voltage	UVLO to OVLO	V

ELECTRICAL CHARACTERISTICS**T_{amb} = 25°C, V_{CC} + 12V (unless otherwise specified)**

Symbol	Parameter	Test Condition	Min.	Typ.	Max.	Unit
CURRENT CONSUMPTION						
I _{CC}	Current Consumption			4	7	mA
STANDBY						
I _{stby}	Current Consumption in Standby Mode			150		μA
V _{sh}	Input Standby Voltage High Impedance	Internal Pull up resistor. Stby pin should be left open	2			V
V _{sl}	Input Standby Voltage Low				0.8	V
OSCILLATOR						
F _{OSC}	Frequency of the Oscillator	C _{OSC} = 220pF	70	100	130	kHz
VOLTAGE CONTROL ^{1) 2)}						
V _{ref}	Voltage Control Reference	T _{amb} = 25°C -25°C < T _{amb} < 85°C	2.450	2.520	2.590	V
CURRENT CONTROL ^{3) 4) 5)}						
V _{sense}	Current Control Reference Voltage	T _{amb} = 25°C -25°C < T _{amb} < 85°C	196 191	206	216 221	mV
GATE DRIVE - P CHANNEL MOSFET DRIVE						
I _{sink}	Sink Current - Switch ON	T _{amb} = 25°C -25°C < T _{amb} < 85°C	15	40		mA
I _{source}	Source Current - Switch OFF	T _{amb} = 25°C -25°C < T _{amb} < 85°C	30	80		mA
C _{load}	Input Capacitance of the PMOSFET ⁶⁾			1	1.5	nF
PWM						
Δ _{max.}	Maximum Duty Cycle of the PWM function			95	100	%
UVLO						
UV	Under Voltage Lock Out ⁷⁾	-25°C < T _{amb} < 85°C	8		9	V
UV _{hyst}	UVLO Voltage Hysteresis - low to high			200		mV
R _{Uvl}	Upper Resistor of UVLO bridge ⁸⁾	T _{amb} = 25°C		184		kΩ
R _{Uvl}	Lower Resistor of UVLO bridge (see note 8)	T _{amb} = 25°C		76.5		kΩ
OVLO						
OV	Over Voltage Lock Out (see note 7)	-25°C < T _{amb} < 85°C	32		35	V
OV _{hyst}	OVLO Voltage Hysteresis - low to high			400		mV
R _{Ovl}	Upper Resistor of OVLO bridge (see note 8)	T _{amb} = 25°C		275		kΩ
R _{Ovl}	Lower Resistor of OVLO bridge (see note 8)	T _{amb} = 25°C		23.2		kΩ

1. V_{ref} parameter indicates global precision of the voltage control loop.

2. Control Gain : A_v = 95dB ; Input Resistance : R_{in} = infinite ; Output Resistance : R_{out} = 700MΩ ; Output Source/Sink Current : I_{so}, I_{sj} = 150μA ; Recommended values for the compensation network are : 22nF & 22kΩ in series between output and ground.

3. V_{sense} parameter indicated global precision of the current control loop.

4. Control Gain : A_v = 105dB ; Input Resistance : R_{in} = 380kΩ ; Output Resistance : R_{out} = 105MΩ ; Output Source/Sink Current : I_{so}, I_{sj} = 150μA ; Recommended values for the compensation network are : 22nF & 22kΩ in series between output and ground.

5. A current foldback function is implemented thanks to a systematic -6mV negative offset on the current amplifier inputs which protects the battery from over charging current under low battery voltage conditions, or output short circuit conditions.

6. The Gate Drive output stage has been optimized for PMosfets with input capacitance equal to C_{load}. A bigger Mosfet (with input capacitance higher than C_{load}) can be used with TSM108, but the gate drive performances will be reduced (in particular when reaching the D_{max}. PWM mode).

7. The given limits comprise the hysteresis (UV_{hyst}).

8. It is possible to modify the UVLO and OVLO limits by adding a resistor (to ground or to V_{CC}) on the pins UV and OV. The internal values of the resistor should be taken into account.

TSM108 AS A STAND ALONE DC/DC CONVERTER FOR CIGARETTE LIGHTER ACCESSORIES

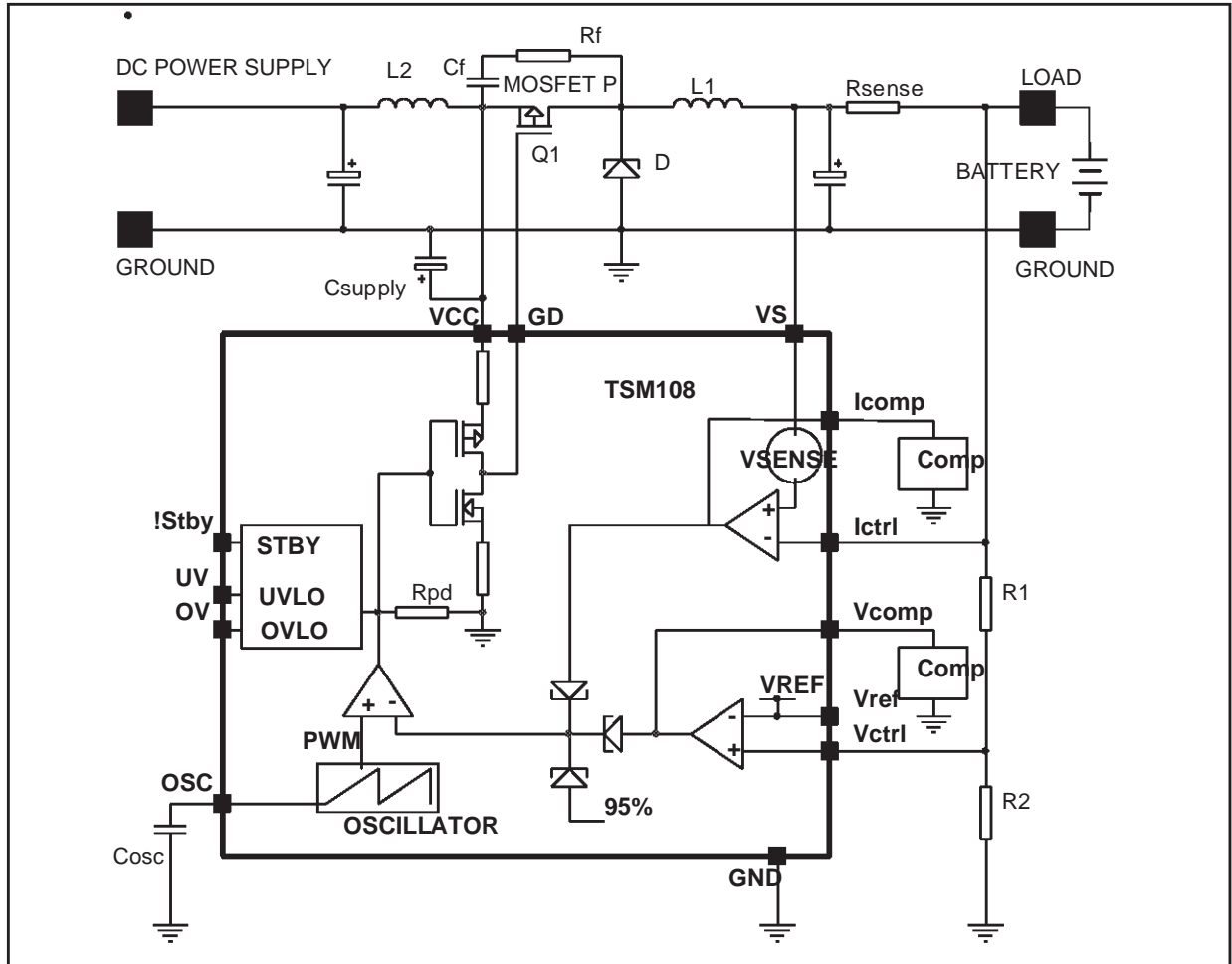

PRINCIPLE OF OPERATION AND APPLICATION HINTS

Description of a DC/DC step down battery charging application

1. Voltage and Current Controller

TSM108 is designed to drive a P-Channel MOSFET transistor in Switch Mode Step Down Converter applications. Its two integrated operational amplifiers ensure accurate Voltage and Current Regulation.

The Voltage Control dedicated operational amplifier acts as an error amplifier and compares a part of the output voltage (external resistor bridge) to an integrated highly precise voltage reference (V_{ref}).

The Current Control dedicated operational amplifier acts as an error amplifier and compares the drop voltage through the sense resistor to an integrated low value voltage reference (V_s).

These two amplified errors are ORed through diodes, and the resulting signal ("max of") is a reference for the PWM generator to set the switching duty cycle of the P-Channel MOSFET transistor.

The PWM generator comprises an oscillator (saw tooth) and a comparator which gives a variable duty cycle from 0 to 95%. This PWM signal is the direct command of the output Push Pull stage to drive the Gate of the P-Channel MOSFET.

Thanks to this architecture, the TSM108 is ideal to be used from a DC power supply to control the charging Voltage and Current of a battery in applications such as Automotive accessories for Portable Phone charging and power supplies.

2. Voltage Control

The Voltage Control loop is to be set thanks to an external resistor bridge connected between the output positive line and the Ground reference. The middle point is to be connected to the V_{ctrl} pin of TSM108, and, if R1 is the upper resistor, and R2, the lower resistor of the bridge, the values of R1 and R2 should follow:

$$\square \text{ eq1: } V_{ref} = V_{out} \times R2 / (R1 + R2)$$

When under Constant Voltage Control mode, the output voltage is fixed thanks to the R1/R2 resistor bridge.

The total value of R1 + R2 resistor bridge will determine the necessary bleeding current to keep the Voltage Control loop effective, even under "no load" conditions.

The current compensation loop is directly accessible from the pins Vcomp and Vref (negative input of the Voltage Control dedicated operational amplifier). The compensation network is highly dependant of the conditions of use of the TSM108 (switching frequency, external components (R, L, C), MOSFET, output capacitor...).

3. Current Control

The Current control loop is to be set thanks to the Sense resistor which is to be placed in series on the output positive line. The output side of the Sense resistor should be connected to the Ictrl pin of TSM108, and the common point between Rsense and the filtering self L should be connected to the Vs pin of TSM108. If Ilim is the value of the charging current limit The value of Rsense should verify:

$$\square \text{ eq2: } V_s = R_{sense} \times I_{lim}$$

When under Constant Current Control mode, the output current is fixed thanks to the Rsense resistor (under output short circuit conditions, please refer to this corresponding section).

The wattage calibration (W) of the sense resistor should be chosen according to:

$$\square \text{ eq2a: } W > R_{sense} \times I_{lim}^2$$

The current compensation loop is directly accessible from the pins Icomp and Ictrl (negative input of the Current Control dedicated operational amplifier).

The compensation network is highly dependant of the conditions of use of the TSM108 (switching frequency, external components (R, L, C), MOSFET, output capacitor...).

4. PWM frequency

The internal oscillator of TSM108 is a saw tooth waveform that can be frequency adjusted.

In automotive accessory battery charging applications, it is recommended to set the switching frequency at a typical 100kHz in order to obtain the

best compromise between electrical noise, and size of the filtering self.

An external capacitor is to be connected between ground and the Osc pin of TSM108 to set the switching frequency.

The maximum duty cycle of the PWM function is limited to 95% in order to ensure safe driving of the MOSFET.

5. Gate Drive

The Gate Drive stage is directly commanded from the PWM output signal. The Gate Drive stage is a Push Pull Mosfet stage which bears different On resistances in order to ensure a slower turn ON than turn OFF of the P-Channel MOSFET. The values of the output Gate Drive currents are given by I_{sink} (switch ON) and I_{source} (switch OFF).

The Gate Drive stage bears an integrated voltage clamp which will prevent the P-Channel MOSFET gate to be driven with voltages higher than 15V (acting like a zener diode between V_{cc} and GD (Gate Drive) pin).

6. Under Voltage Lock-Out, Over Voltage Lock-Out

The UVLO and OVLO security functions aim at the global application security.

When the Power supply decreases, there is the inherent risk to drive the P-Channel MOSFET with insufficient Gate voltage, and therefore to lead the MOSFET to linear operation, and to its destruction.

The UVLO is an input power supply voltage detection which imposes a complete switch OFF of the P-Channel MOSFET as soon as the Power Supply decreases below UV. To avoid unwanted oscillation of the MOSFET, a fixed hysteresis margin is integrated (UV_{hyst}).

UVLO is internally programmed to ensure 8V min and 9V max, but the middle point of the integrated resistor bridge is accessible and the value of the UVLO is therefore adjustable by adding an external resistor to modify the bridge ratio. The resistor typical values of the bridge are given (R_{uvh} , R_{uvl}).

When the Power supply increases, there is the inherent risk to dissipate too much conduction energy through the P-Channel MOSFET, and therefore to lead to its destruction.

The OVLO is an input power supply voltage detection which imposes a complete switch OFF of the P-Channel MOSFET as soon as the Power Supply increases above OV. To avoid unwanted oscillation of the MOSFET, a fixed hysteresis margin is integrated (OV_{hyst}).

OVLO is internally programmed to ensure 32V min. and 33V max., but the middle point of the integrated resistor bridge is accessible and the value of the OVLO is therefore adjustable by adding an external resistor to modify the bridge ratio.

The resistor typical values of the bridge are given (R_{ovh} , R_{ovl}).

Examples:

Let's suppose that the internally set value of the UVLO and / or OVLO level should be modified in a specific application, or under specific requirements.

6.1. UVLO decrease:

If the UVLO level needs to be lowered (UV1), an additional resistor (R_{uvh1}) must be connected between UV and V_{cc} following the equation:

$$\begin{aligned} \square \quad UV &= V_{ref} (R_{uvh}/R_{uvl} + 1) \\ \square \quad UV1 &= V_{ref} ((R_{uvh}/R_{uvh1})/R_{uvl} + 1) \quad (i) \end{aligned}$$

where R_{uvh}/R_{uvh1} means that R_{uvh1} is in parallel to R_{uvh}

Solving i. we obtain:

$$\square \quad R_{uvh1} = R_{uvl} \times R_{uvh} (UV1 - V_{ref}) / (V_{ref} \times R_{uvh} - R_{uvl} (UV1 - V_{ref}))$$

As an example, if UV1 needs to be set to 6V, $R_{uvh1} = 256k\Omega$

6.2. UVLO increase:

If the UVLO level needs to be increased (UV2), an additional resistor (R_{uvl2}) must be connected between UV and Gnd following the equation.

$$\begin{aligned} \square \quad UV &= V_{ref} (R_{uvh}/R_{uvl} + 1) \\ \square \quad UV1 &= V_{ref} (R_{uvh}/(R_{uvl}/R_{uvl2}) + 1) \quad (ii) \end{aligned}$$

where R_{uvl}/R_{uvl2} means that R_{uvl2} is in parallel to R_{uvl}

Solving ii. we obtain:

$$\square \quad R_{uvl2} = V_{ref} \times R_{uvh} \times R_{uvl} / (UV2 \times R_{uvl} - V_{ref} \times (R_{uvh} + R_{uvl}))$$

As an example, if UV2 needs to be set to 12V, $R_{uvl2} = 132k\Omega$

6.3. OVLO decrease:

If the OVLO level needs to be lowered (OV1), an additional resistor (R_{ovh1}) must be connected between OV and V_{cc} following the equation:

$$\begin{aligned} \square \quad OV &= V_{ref} (R_{ovh}/R_{ovl} + 1) \\ \square \quad OV1 &= V_{ref} ((R_{ovh}/R_{ovh1})/R_{ovl} + 1) \quad (iii) \end{aligned}$$

where R_{ovh}/R_{ovh1} means that R_{ovh1} is in parallel to R_{ovh}

Solving iii. we obtain:

$$\square \quad R_{ovh1} = R_{ovl} \times R_{ovh} (OV1 - V_{ref}) / (V_{ref} \times R_{ovh} - R_{ovl} (OV1 - V_{ref}))$$

As an example, if OV1 needs to be set to 25V, $R_{ovh1} = 867k\Omega$

6.4. OVLO increase:

If the OVLO level needs to be increased (OV2), an additional resistor (Rovl2) must be connected between OV and Gnd following the equation.

- $OV = V_{ref} (R_{ovh}/R_{ovl} + 1)$
- $OV2 = V_{ref} (R_{ovh}/(R_{ovl}/R_{ovl2} + 1))$ (iv)

where R_{ovl}/R_{ovl2} means that R_{ovl2} is in parallel to R_{ovl}

Solving iv. we obtain:

- $R_{ovl2} = V_{ref} \times R_{ovh} \times R_{ovl} / (OV2 \times R_{ovl} - V_{ref} \times (R_{ovh} + R_{ovl}))$

As an example, if OV2 needs to be set to 40V, $R_{ovl2} = 87k\Omega$

7. Standby Mode

In order to reduce to a minimum the current consumption of the TSM108 when in inactive phase, the Standby mode (!Stby pin of TSM108) imposes a complete OFF state of the P-Channel MOSFET, as well as a complete shut off of the main functions of the TSM108 (operational amplifier, PWM generator and oscillator, UVLO and OVLO) and therefore reduces the consumption of the TSM108 to the !stby value.

This !Stby command is TTL compatible, which means that it can be directly commanded from whatever logic signal.

8. Power Transistor: P-MOSFET or PNP Transistor?

The TSM108 can drive, with minor external components change, either a P-channel MOSFET, or a PNP transistor. The choice of the transistor is completely to the user's responsibility, nevertheless, here follows a few elements which will help to decide which is the most adapted transistor to drive depending on the application characteristics in terms of power and performances.

The following figures shows two different schematics where both driving abilities of TSM108 are shown. The third schematic shows how to improve the switch off commutation when using a bipolar PNP transistor.

P- MOSFET? PNP Transistor?

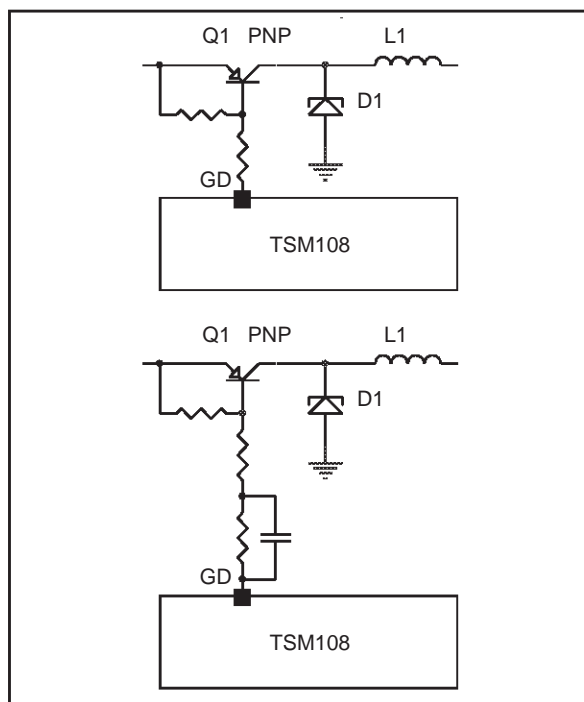
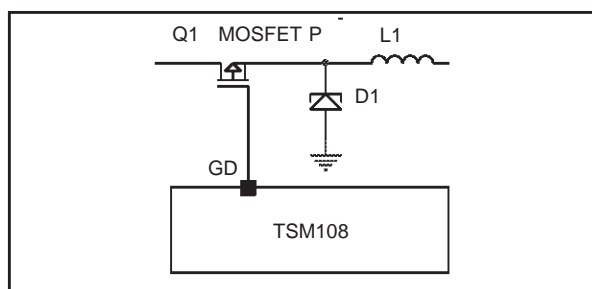

The most immediate way to choose from a P-channel MOSFET or a PNP transistor is to consider the ratio between the output power of the application and the expected components price: the lower the power, the more suitable the PNP transistor is; the higher the power, the more suitable the P-channel MOSFET is. As an example, for a DC/DC adaptor built for 12V/6V, the recommended limit to choose from one to the other is situated around 200mA.

Below 200mA, the price/performance ration of the PNP transistor is very attractive, whereas above 200mA, the P-channel Mosfet takes the advantage.

9. Calculation of the Passive Elements

Let's consider the following characteristics for a Cigarette Lighter Cellular Phone Battery Charger:

$V_{in} = 12V$ - input voltage of the converter

$V_{out} = 6V$ - output voltage of the converter

$F = 100kHz$ - switching frequency of the converter adjustable with an external capacitor

$I_{out} = 625mA$ - output current limitation

9.1. Inductor

The minimum inductor value to choose should apply to

$$L_{min} = (1 - D) R / 2F$$

where $R = V_{out} / I_{out} = 9.6W$

and where $D = V_{out} / V_{in} = 0.5$

Therefore, $L_{min} = 24\mu H$.

This component value is valid if the above described characteristics are fixed... but in the automotive field, the input voltage of the converter is dependant of the car battery conditions. Also, the frequency may vary depending on the temperature, due to the fact that the frequency is fixed by an external capacitor. Therefore, we must calculate the inductor value considering the worst case condition in order to avoid the saturation of the inductor, which is when the battery voltage is at it's highest, and the switching frequency at it's lowest. Thanks to the OVLO function integrated in TSM108, the operation of the DC/DC converter will be stopped as soon as the voltage exceeds the OVLO level. Let's suppose the OVLO pin has been left open, therefore, the maximum input voltage of the DC/DC converter will be $V_{in\ max.} = 32V$. Frequency min stands in the range of 75kHz. In this case, $D = 6 / 32 = 0.1875$, therefore $L_{min} = 52\mu H$.

If we allow a 25% security margin

$$L_{min} = 68\mu H$$

9.2. Capacitor

The capacitor choice will depend mainly on the accepted voltage ripple on the output

$$Ripple = DV_{out} / V_{out} = (1-D) / 8LCF$$

Therefore, $C = (1-D) / 8LRippleF$. If $C = 22\mu F$, then $Ripple = 0.4\%$ which should be far acceptable.

Here again, the worst conditions for the ripple are set when the input voltage is at the highest (32V) and the frequency at it's lowest (75kHz).

with $C = 22\mu F$, $Ripple = 1.2\%$

9.3. Ratings for the Inductor, Capacitor, Transistor and Diode

The inductor wire must be rated at the rms current, and the core should not saturate for peak inductor current. The capacitor must be selected to limit the output ripple to the design specifications, to withstand peak output voltage, and to carry the required rms current.

The transistor and the diode should be rated for the maximum input voltage (up to 60V in automotive applications). The diode recovery time must be in accordance with the time period and the maximum authorised switching time of the power transistor.

A compromise between the switching and conducting performances of the transistor must be found, because choosing a very low ohmic Mosfet aiming at the benefit of low conduction losses may bring much higher switching losses than the expected benefit.

Losses in the switch are:

$$P_{switch} = P_{rise} + P_{fall} + P_{on}$$

where $P_{rise} + P_{fall}$ represent the switching losses and where P_{on} represents the conduction losses.

$$P_{rise} + P_{fall} = I_{out} \times V_{in} \times (T_{rise} + T_{fall}) \times F / 2$$

$$P_{on} = R_{on} \times I_{out} \times d$$

where T_{rise} is the switching on time, and T_{fall} is the switching off time, and where d is the duty cycle of the switching profile, which can be approximated to 1 under full load conditions.

With the two last equations, we can see easily that what we may gain by choosing a performing low R_{dson} Pchannel MOSFET (for example) may be jeopardised by the long on and off switching times required when using a large input gate capacitance.

10. Electromagnetic Compatibility

The small schematic hereafter shows how to reduce the EMC noise when used in an EMC sensitive environment:

EMC Improvement

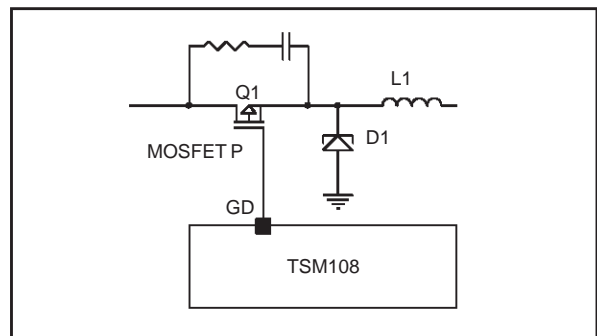

The RC components should realise a time constant corresponding to one tenth of the switching time constant of the TSM108 (i.e. in our example, the oscillator frequency is set to 10µs corresponding to 100kHz, therefore, the RC couple should realise a time constant close to 1µs).

Choosing the components must privilege a rather small resistivity (between 10 to 100W). A guess couple of values for RC in our example would be: $R = 22W$, $C = 47nF$

11. Efficiency Calculations (rough estimation)

The following gives a rough estimation of the efficiency of a car phone charger, knowing that the exact calculations depend on a lot of parameters, as well as on a wide choice of external components.

Let's consider the following characteristics of a classical car phone charger application:

- Vin = Vcc = 12V, Iout = 625mA, Vout = 6V
- Mosfet: Pchannel Mosfet: Rds(on) = 100mΩ, Ciss = 1nF.
- Driver: TSM108
- PWM frequency: 100kHz
- Free wheel diode: Vf = 0.7V
- Shunt: Rsense = 330mΩ

The efficiency (η) of a regulator is defined as the ratio of the charging power (Pout) to the total power from the supply (Pin).

$$\text{Eq3: } \eta = P_{\text{out}} / P_{\text{in}}$$

The output power is:

$P_{\text{out}} = I_{\text{out}} \times V_{\text{out}}$ where Iout is the charging current ($V_{\text{sense}} / R_{\text{sense}} = 625\text{mA}$ at full load) and Vout is the regulated voltage ($V_{\text{ref}}(1+R1/R2) = 6\text{V}$).

$$P_{\text{out}} = 3.75\text{W}$$

The input power can be found by adding the output power (Pout) to the total power loss in the circuit (Plosses) i.e.

$$\text{Pin} = P_{\text{out}} + P_{\text{losses}}$$

The power is lost partly on the chip and partly on the external components which are mainly the diode, the switch and the shunt. $P_{\text{losses}} = P_{\text{chip}} + P_{\text{switch}} + P_{\text{diode}} + P_{\text{shunt}}$.

In Plosses, we neglect the losses in the inductor (because the current through the inductor is smoothed making the serial resistor of the inductor very low), and the losses in the Gate (charge and discharge).

a. The power lost in the chip is $P_{\text{chip}} = V_{\text{cc}} \times I_{\text{cc}}$. ($V_{\text{cc}} = 12\text{V}$, $I_{\text{cc}} = 6\text{mA}$) $P_{\text{chip}} = 72\text{mW}$

b. The power lost in the switch depends on the ON resistance of the switch and the current passing through it. Also there is power loss in the switch during switching time (commutation losses) and that depends on the switching frequency and the rise and fall time of the switching signal.

Rise time (Pchannel goes off) depends on the output source current of the TSM108 and the input gate capacitance of the Mosfet.

$$T_{\text{rise}} = C_{\text{iss}} \times V_{\text{gate}} / I_{\text{source}}$$

Fall time (Pchannel goes on) depends on the output sink current of the TSM108 and the input gate capacitance of the Mosfet .

$$T_{\text{fall}} = C_{\text{iss}} \times V_{\text{gate}} / I_{\text{sink}}$$

$T_{\text{rise}} = 150\text{ns}$ and $T_{\text{fall}} = 300\text{ns}$ (V_{gate} is approx 12V).

$$P_{\text{switch}} = P_{\text{rise}} + P_{\text{fall}} + P_{\text{on}}$$

where:

$$P_{\text{rise}} = I_{\text{out}} \times (V_{\text{cc}} + V_{\text{f}}) \times T_{\text{rise}} \times \text{PWMfreq} / 2$$

$$P_{\text{rise}} = 625\text{mA} \times 12.7 \times 150\text{ns} \times 100\text{kHz} / 2.$$

$$P_{\text{rise}} = 59.5\text{mW}$$

where:

$$P_{\text{fall}} = I_{\text{out}} \times (V_{\text{cc}} + V_{\text{f}}) \times T_{\text{fall}} \times \text{PWMfreq} / 2$$

$$P_{\text{fall}} = 625\text{mA} \times 12.7 \times 300\text{ns} \times 100\text{kHz} / 2.$$

$$P_{\text{fall}} = 119.1\text{mW}$$

where:

$P_{\text{on}} = R_{\text{ds(on)}} \times I_{\text{out}} \times D$ (where D is the duty cycle - at full charge, D can be approximated to 1)

$$P_{\text{on}} = 100\text{m}\Omega \times 625\text{mA} \cdot P_{\text{on}} = 39.1\text{mW}$$

$$P_{\text{switch}} = 217.7\text{mW}$$

c. The power lost in the fly back diode is $P_{\text{diode}} = V_{\text{f}} \times I_{\text{out}}(1-D)$ where $D = V_{\text{out}} / V_{\text{cc}} = 6/12$. $D = 0.5$

$$P_{\text{diode}} = 219\text{mW}$$

d. the power lost in the sense resistor (shunt resistor) is $P_{\text{shunt}} = R_{\text{sense}} \times I_{\text{out}}^2$

$$P_{\text{shunt}} = 129\text{mW}$$

Therefore,

$$P_{\text{losses}} = P_{\text{chip}} + P_{\text{switch}} + P_{\text{diode}} + P_{\text{shunt}}$$

$$= 72\text{mW} + 217.7\text{mW} + 219\text{mW} + 129\text{mW}$$

$$P_{\text{losses}} = 638\text{mW}$$

The yield (efficiency) is

$$P_{\text{out}} / P_{\text{in}} = 3.75 / (3.75 + 0.638) = 85.5\%$$

$$\eta = 85.5\%$$

The following table gives a tentative yield improvement view following the choice of some external components. Be aware that some of the following choices have non negligible cost effects on the total application.

Improved yield - by changing the external components value one by one

Rsense	330mΩ	220mΩ	-	-	-	-
Iout	625mA	936mA	-	-	-	-
Vout (R1/R2)	6V	-	7.5V	-	-	-
Rds(on)	100mΩ	-	-	140mΩ	-	-
Ciss	0nF	-	-	0.85nF	-	-
PWM Freq	100kHz	-	-	-	50kHz	-
Free Wheel	0.7V	-	-	-	-	0.3V
Yield	85.5%	85.6%	88.9%	85.7%	87.3%	88.1%
Cost influence	-	=	=	<	>	>>

12. Measured Performances

The few following curves show the measured performances of TSM108 used in DC/DC step down

converter, either with a Pchannel MOSFET or with a PNP bipolar transistor.

12.1. Voltage and Current Control, Efficiency Performances using a Pchannel MOSFET:

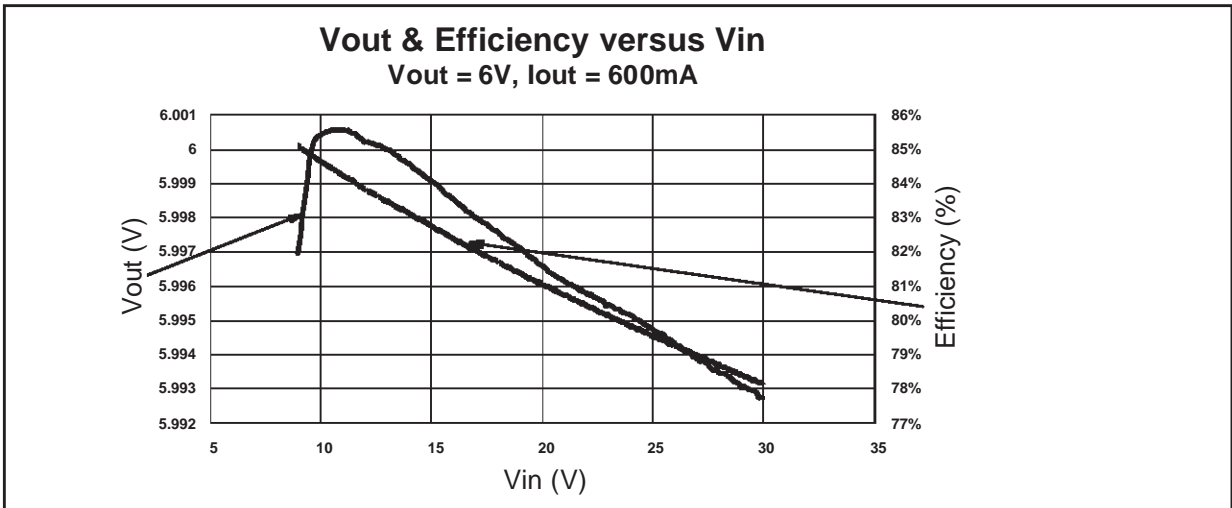
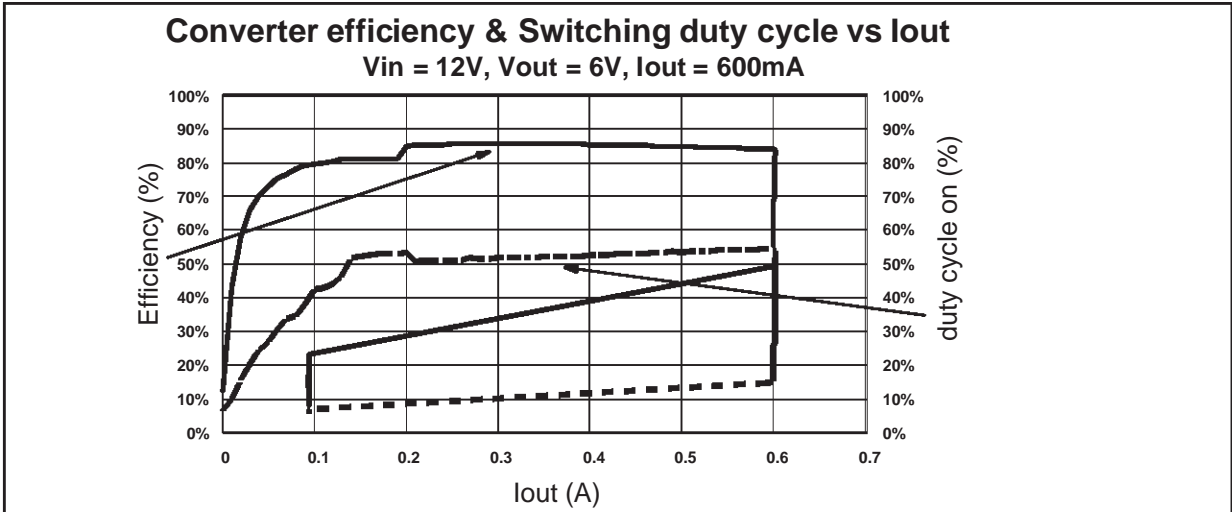
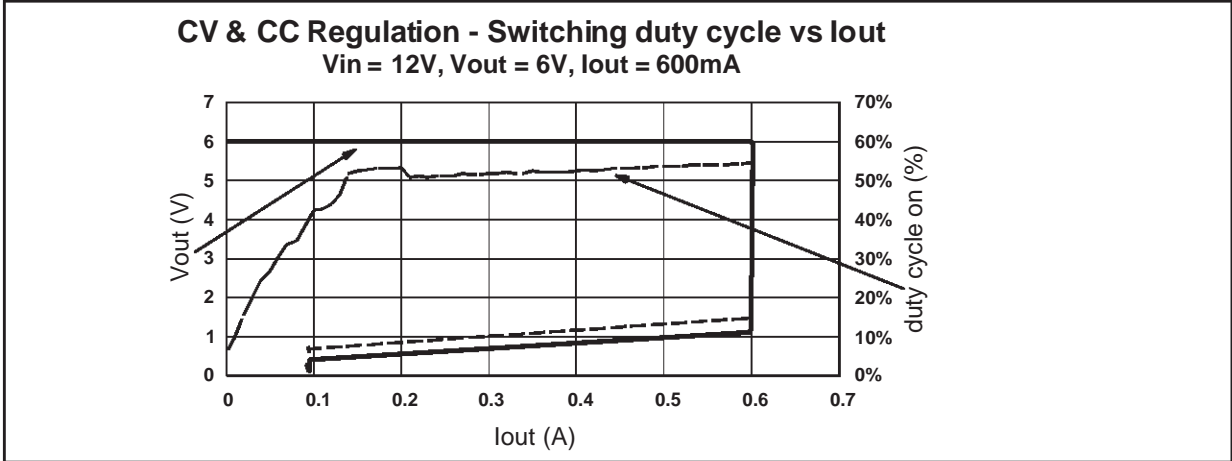

12.2. Voltage and Current Control, Efficiency Performances using a PNP bipolar transistor

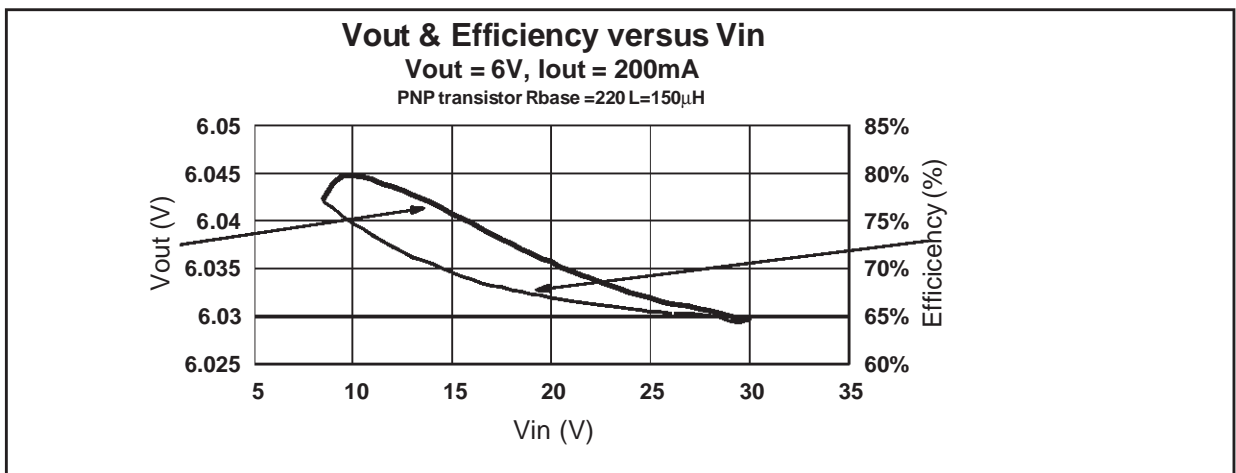
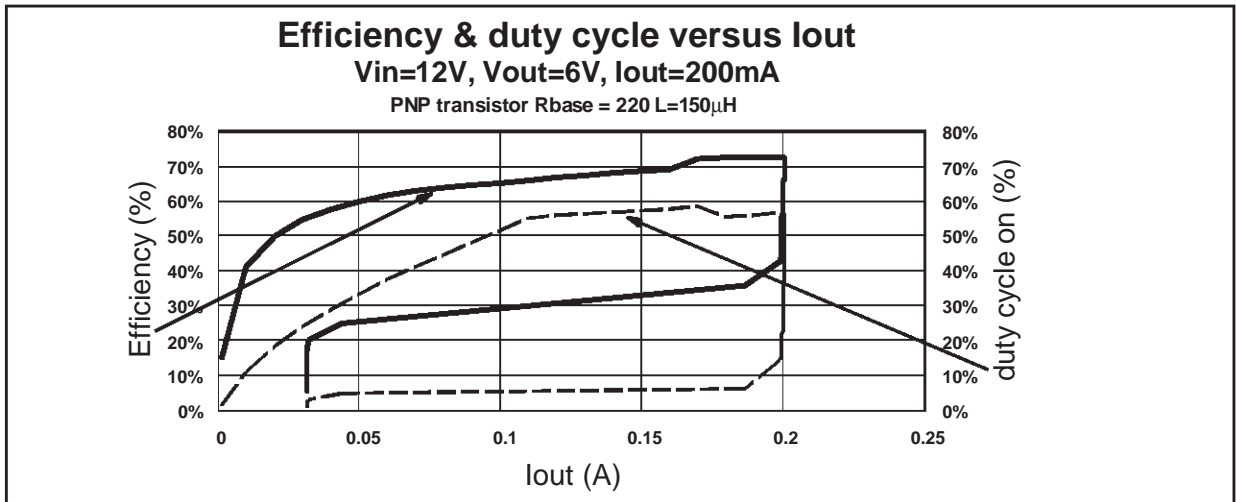
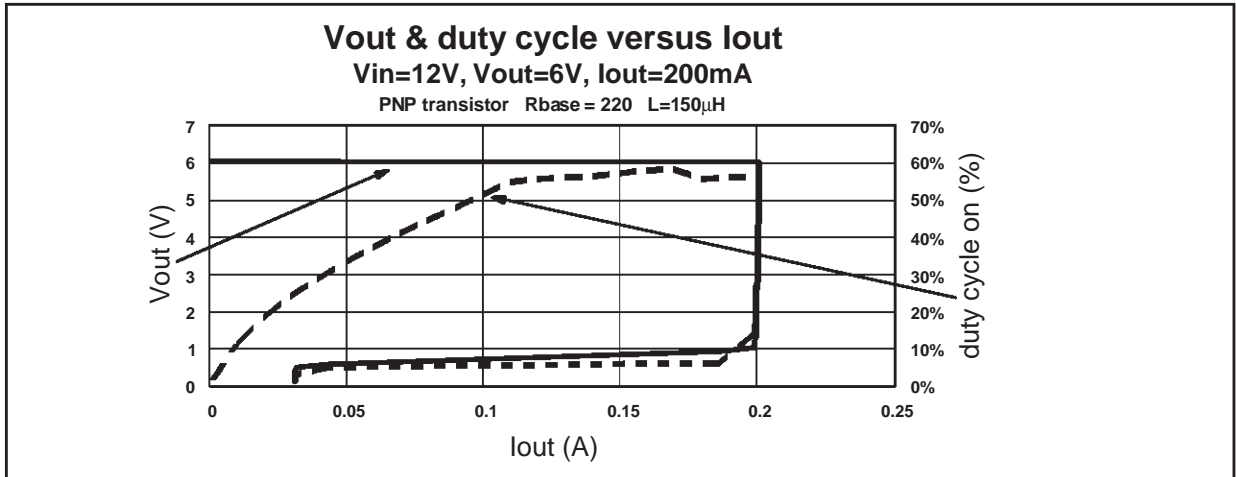

TSM108

PACKAGE MECHANICAL DATA 14 PINS - PLASTIC MICROPACKAGE (SO)

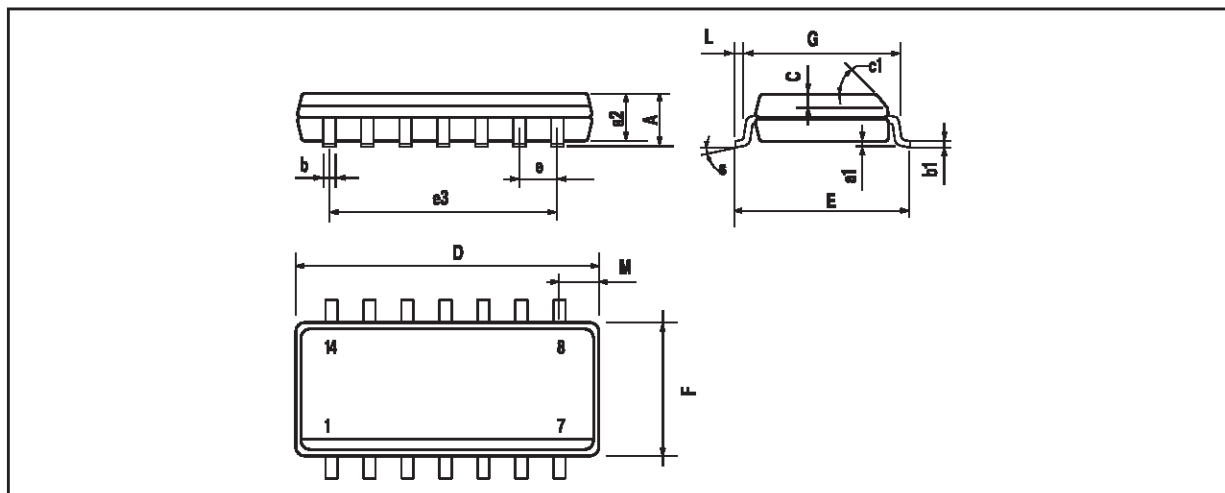

Dim.	Millimeters			Inches		
	Min.	Typ.	Max.	Min.	Typ.	Max.
A			1.75			0.069
a1	0.1		0.2	0.004		0.008
a2			1.6			0.063
b	0.35		0.46	0.014		0.018
b1	0.19		0.25	0.007		0.010
C		0.5			0.020	
c1						45° (typ.)
D (1)	8.55		8.75	0.336		0.344
E	5.8		6.2	0.228		0.244
e		1.27			0.050	
e3		7.62			0.300	
F (1)	3.8		4.0	0.150		0.157
G	4.6		5.3	0.181		0.208
L	0.5		1.27	0.020		0.050
M			0.68			0.027
S						8° (max.)

Note : (1) D and F do not include mold flash or protrusions - Mold flash or protrusions shall not exceed 0.15mm (.066 inc) ONLY FOR DATA BOOK.

Information furnished is believed to be accurate and reliable. However, STMicroelectronics assumes no responsibility for the consequences of use of such information nor for any infringement of patents or other rights of third parties which may result from its use. No license is granted by implication or otherwise under any patent or patent rights of STMicroelectronics. Specifications mentioned in this publication are subject to change without notice. This publication supersedes and replaces all information previously supplied. STMicroelectronics products are not authorized for use as critical components in life support devices or systems without express written approval of STMicroelectronics.

© The ST logo is a registered trademark of STMicroelectronics

© 2000 STMicroelectronics - Printed in Italy - All Rights Reserved
STMicroelectronics GROUP OF COMPANIES

Australia - Brazil - China - Finland - France - Germany - Hong Kong - India - Italy - Japan - Malaysia - Malta - Morocco
 Singapore - Spain - Sweden - Switzerland - United Kingdom

© <http://www.st.com>

