



DC-DC CONVERTER CONTROL CIRCUITS

- OUTPUT SWITCH CURRENT IN EXCESS OF 1.5A
- 2% REFERENCE ACCURACY
- LOW QUIESCENT CURRENT: 2.5mA (TYP.)
- OPERATING FROM 3V TO 40V
- FREQUENCY OPERATION TO 100KHz
- ACTIVE CURRENT LIMITING

DESCRIPTION

The MC34063A/E series is a monolithic control circuit delivering the main functions for DC-DC voltage converting.

The device contains an internal temperature compensated reference, comparator, duty cycle controlled oscillator with an active current limit circuit, driver and high current output switch.

Output voltage is adjustable through two external resistors with a 2% reference accuracy.

Employing a minimum number of external components the MC34063A/E devices series is designed for Step-Down, Step-Up and Voltage-Inverting applications.

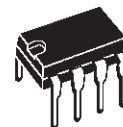

DIP-8



SO-8

BLOCK DIAGRAM

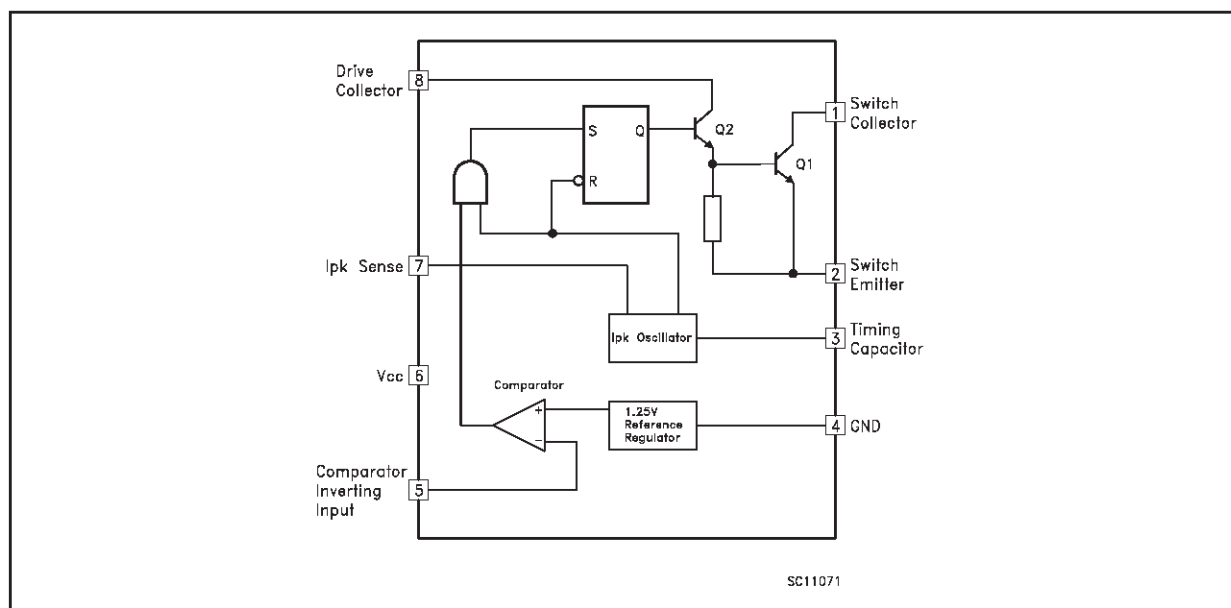

ABSOLUTE MAXIMUM RATINGS

Symbol	Parameter	Value	Unit
V _{CC}	Power Supply Voltage	50	V
V _{ir}	Comparator Input Voltage Range	-0.3 to 40	V
V _{SWC}	Switch Collector Voltage	40	V
V _{SWE}	Switch Emitter Voltage (V _{SWC} = 40V)	40	V
V _{CE}	Switch Collector to Emitter Voltage	40	V
V _{dc}	Driver Collector Voltage	40	V
I _{dc}	Driver Collector Current	100	mA
I _{SW}	Switch Current	1.5	A
P _{tot}	Power Dissipation at T _{amb} = 25 °C (for Plastic Package) (for SOIC Package)	1.25 0.625	W
T _{op}	Operating Ambient Temperature Range (for AC and EC SERIES) (for AB SERIES) (for EB SERIES)	0 to 70 - 40 to 85 - 40 to 125	°C °C °C
T _{stg}	Storage Temperature Range	- 40 to 150	°C

Absolute Maximum Rating are those values beyond which damage to the device may occur. Functional operation under these condition is not implied.

THERMAL DATA

Symbol	Parameter	DIP-8	SO-8	Unit
R _{thj-amb}	Thermal Resistance Junction-ambient (*)	Max 100	160	°C/W

(*) This value depends from thermal design of PCB on which the device is mounted.

CONNECTION DIAGRAM (top view)

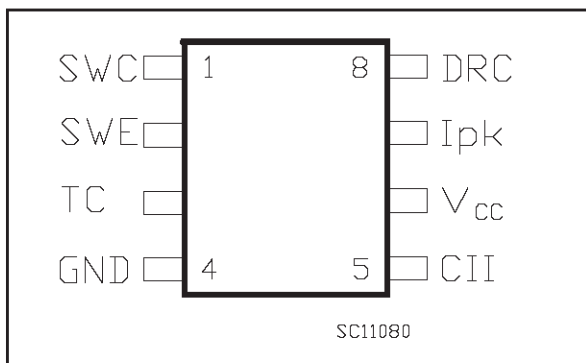

PIN CONNECTIONS

Pin No	Symbol	Name and Function
1	SWC	Switch Collector
2	SWE	Switch Emitter
3	TC	Timing Capacitor
4	GND	Ground
5	CII	Comparator Inverting Input
6	V _{CC}	Voltage Supply
7	I _{pk}	I _{pk} Sense
8	DRC	Voltage Driver Collector

ORDERING NUMBERS

Type	DIP-8	SO-8	SO-8 (tape & reel)
MC34063AB	MC34063ABN	MC34063ABD	MC34063ABD-TR
MC34063AC	MC34063ACN	MC34063ACD	MC34063ACD-TR
MC34063EB	MC34063EBN	MC34063EBD	MC34063EBD-TR
MC34063EC	MC34063ECN	MC34063ECD	MC34063ECD-TR

ELECTRICAL CHARACTERISTICS (Refer to the test circuits, $V_{CC} = 5V$, $T_a = T_{LOW}$ to T_{HIGH} , unless otherwise specified, see note 2)

OSCILLATOR

Symbol	Parameter	Test Conditions	Min.	Typ.	Max.	Unit
f_{OSC}	Frequency	$V_{pin5} = 0V$ $C_T = 1nF$ $T_a = 25^\circ C$	24	33	42	KHz
I_{chg}	Charge Current	$V_{CC} = 5$ to $40V$ $T_a = 25^\circ C$	24	33	42	μA
I_{dischg}	Discharge Current	$V_{CC} = 5$ to $40V$ $T_a = 25^\circ C$	140	200	260	μA
I_{dischg}/I_{chg}	Discharge to Charge Current Ratio	Pin 7 = V_{CC} $T_a = 25^\circ C$	5.2	6.2	7.5	
$V_{ipk(sense)}$	Current Limit Sense Voltage	$I_{chg} = I_{dischg}$ $T_a = 25^\circ C$	250	300	350	mV

OUTPUT SWITCH

Symbol	Parameter	Test Conditions	Min.	Typ.	Max.	Unit
$V_{CE(sat)}$	Saturation Voltage, Darlington Connection	$I_{SW} = 1A$ Pins 1, 8 connected		1	1.3	V
$V_{CE(sat)}$	Saturation Voltage	$I_{SW} = 1A$ $R_{pin8} = 82\Omega$ to V_{CC} , Forced $\beta \sim 20$		0.45	0.7	V
h_{FE}	DC Current Gain	$I_{SW} = 1A$ $V_{CE} = 5V$ $T_a = 25^\circ C$	50	120		
$I_{C(off)}$	Collector Off-State Current	$V_{CE} = 40V$		0.01	100	μA

COMPARATOR

Symbol	Parameter	Test Conditions	Min.	Typ.	Max.	Unit
V_{th}	Threshold Voltage	$T_a = 25^\circ C$ $T_a = T_{LOW}$ to T_{HIGH}	1.225 1.21	1.25	1.275 1.29	V V
Reg_{line}	Threshold Voltage Line Regulation	$V_{CC} = 3$ to $40V$		1	5	mV
I_B	Input Bias Current	$V_{IN} = 0V$		-5	-400	nA

TOTAL DEVICE

Symbol	Parameter	Test Conditions	Min.	Typ.	Max.	Unit
I_{CC}	Supply Current	$V_{CC} = 5$ to $40V$ $C_T = 1nF$ Pin 7 = V_{CC} $V_{pin5} > V_{th}$ Pin 2 = GND Remaining pins open for MC34063A for MC34063E		2.5 1.5	4 4	mA mA
$V_{START-UP}$	Start-up Voltage (note 4)	$T_a = 25^\circ C$ $C_T = 1\mu F$ Pin 5 = $0V$ for MC34063A for MC34063E		2.1 1.5		V V

NOTES:

- Maximum package power dissipation limit must be observed.
- $T_{LOW} = 0^\circ C$, $T_{HIGH} = 70^\circ C$ (AC and EC series); $T_{LOW} = -40^\circ C$, $T_{HIGH} = 85^\circ C$ (AB and EB series).
- If Darlington configuration is not used, care must be taken to avoid deep saturation of output switch. The resulting switch-off time may be adversely affected. In a Darlington configuration the following output driver condition is suggested:
Forced β of output current switch = $I_{COUTPUT}/(I_{CDRIVER} - 1mA^*) \geq 10$
* Current less due to a built in 1K Ω antileakage resistor.
- Start-up Voltage is the minimum Power Supply Voltage at which the internal oscillator begins to work.

TYPICAL ELECTRICAL CHARACTERISTICS

Emitter Follower Configuration Output Saturation Voltage vs Emitter Current

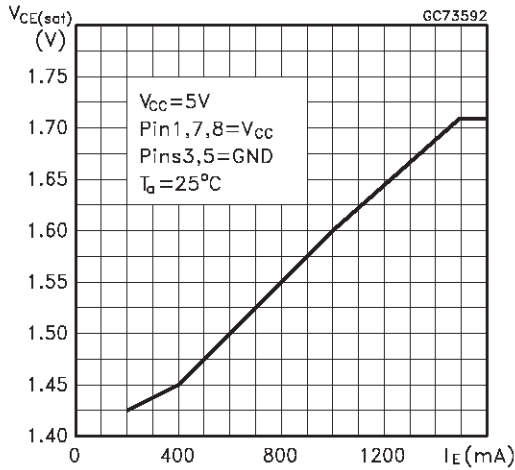

Output Switch ON-OFF Time vs Oscillator Timing Capacitor

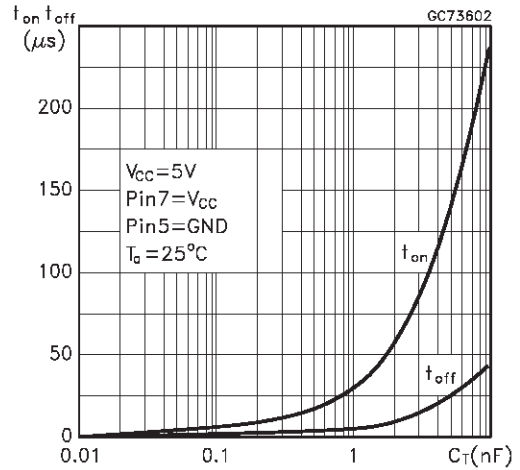

Common Emitter Configuration Output Switch Saturation Voltage vs Collector Current

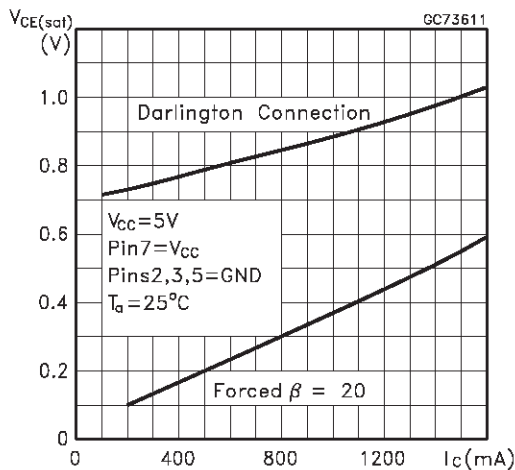

Darlington Configuration Collector Emitter Saturation Voltage ($V_{CE(sat)}$) vs Temperature

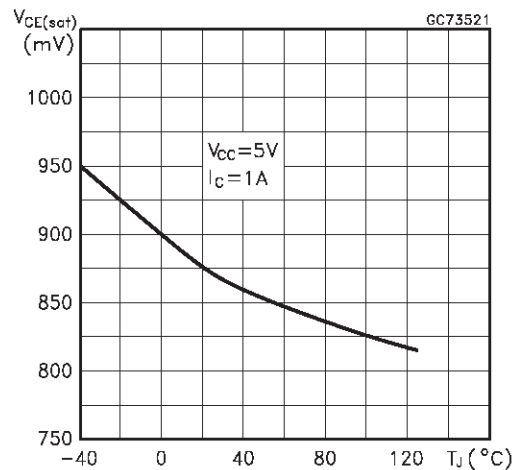

Power Collector Emitter Saturation Voltage ($V_{CE(sat)}$) vs Temperature

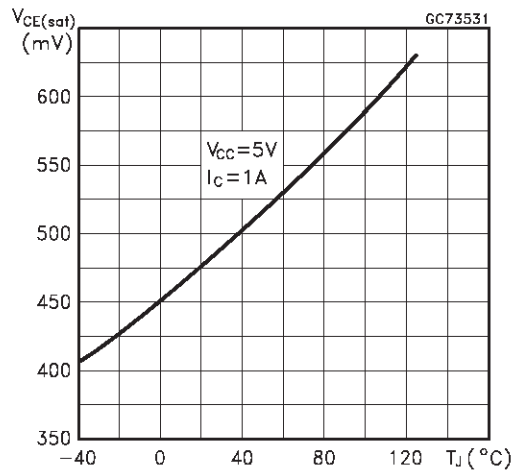

Current Limit Sense Voltage (V_{ipk}) vs Temperature

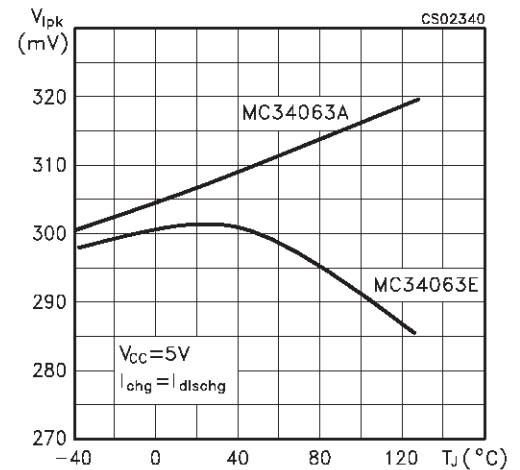

TYPICAL ELECTRICAL CHARACTERISTICS (Continued)

Reference Voltage vs Temperature

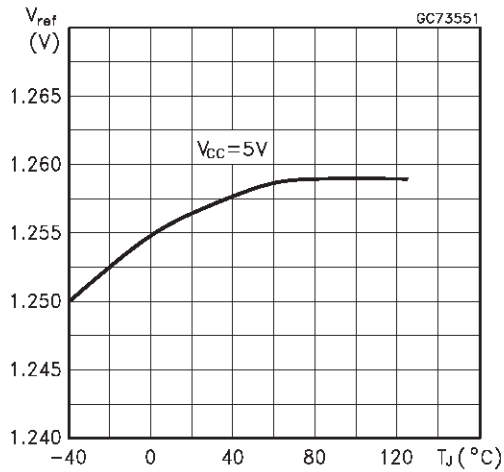

Bias Current vs Temperature

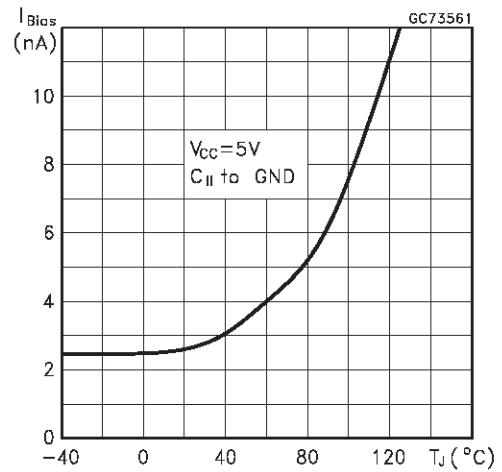

Supply Current vs Temperature

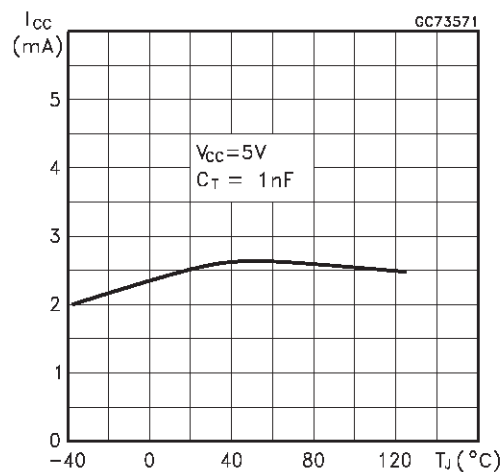

Supply Current vs Input Voltage

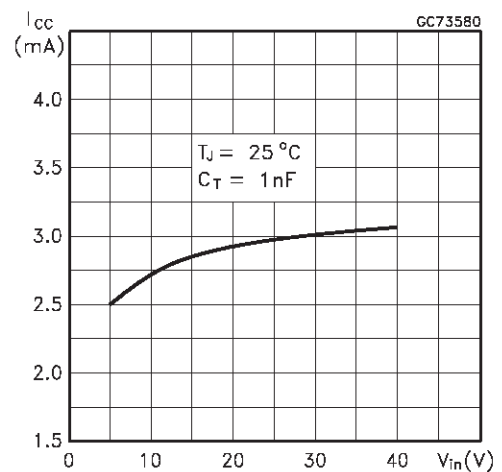

TYPICAL APPLICATION CIRCUIT

Step-Up Converter

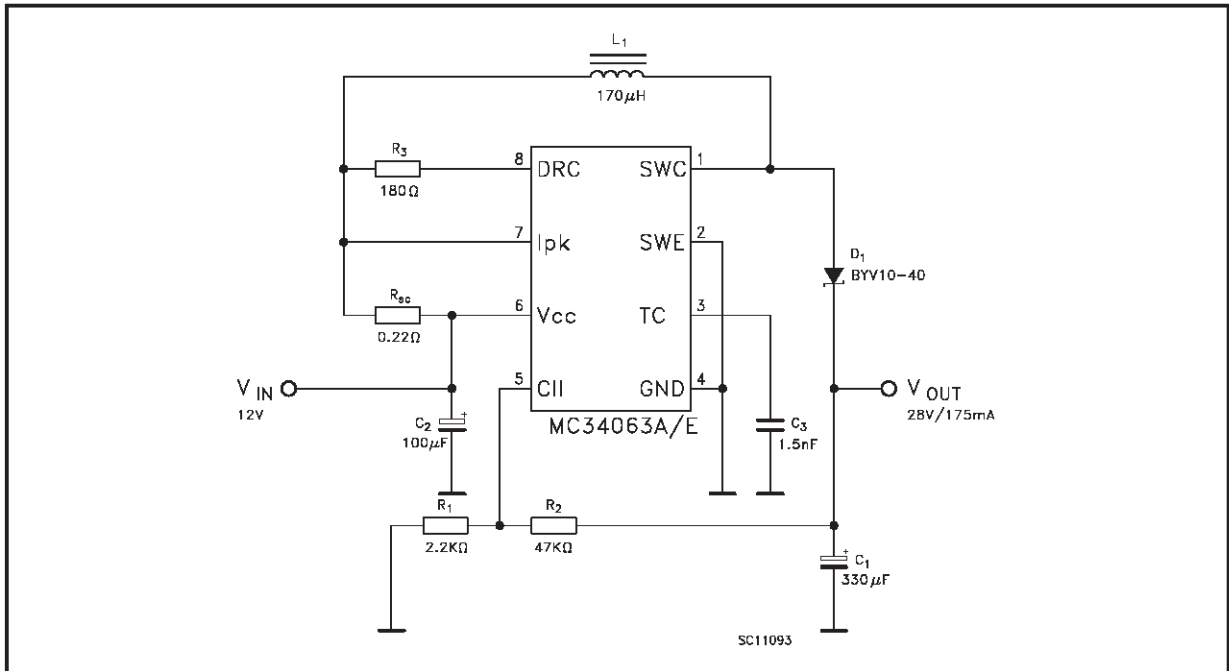

Printed Demoboard

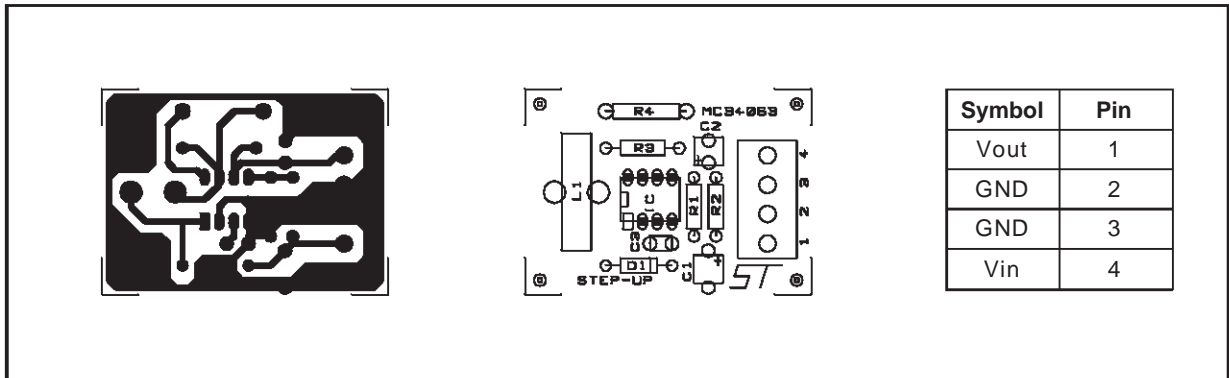

Test Condition ($V_{OUT} = 28V$)

Test	Conditions	Value (Typ.)	Unit
Line Regulation	$V_{IN} = 8 \text{ to } 16V, I_O = 175 \text{ mA}$	30	mV
Load Regulation	$V_{IN} = 12V, I_O = 75 \text{ to } 175 \text{ mA}$	10	mV
Output Ripple	$V_{IN} = 12V, I_O = 175 \text{ mA}$	300	mV
Efficiency	$V_{IN} = 12V, I_O = 175 \text{ mA}$	89	%

Step-Down Converter

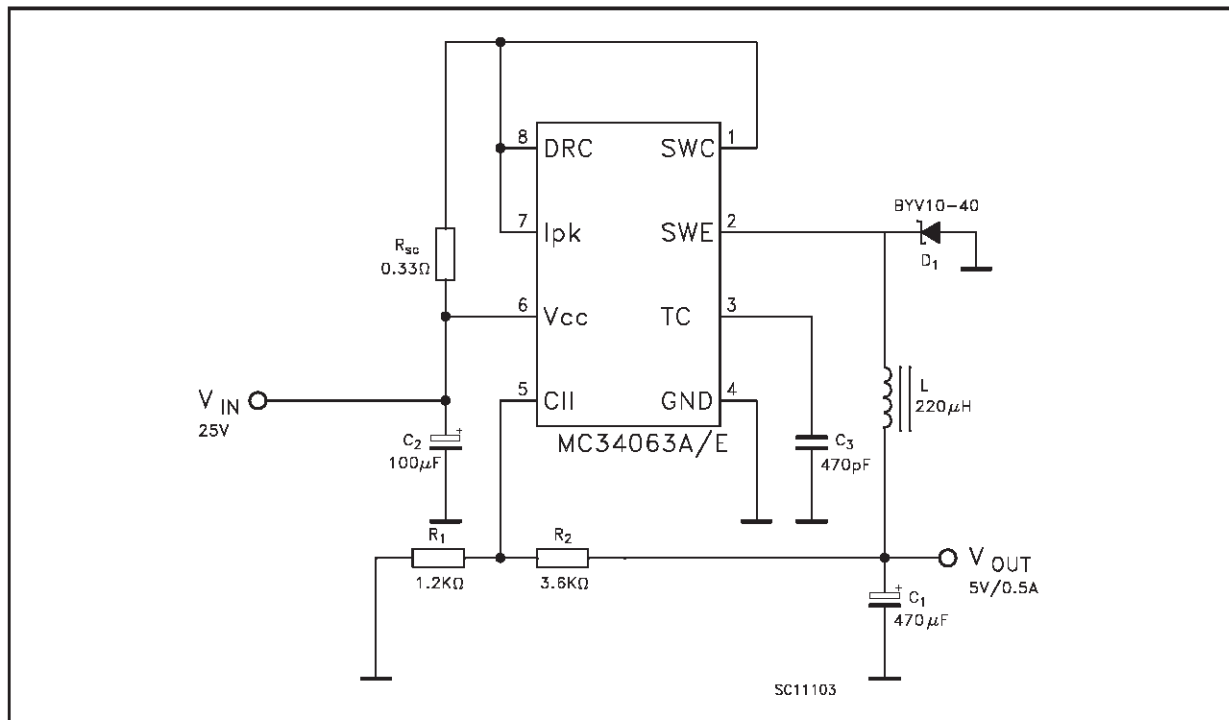

Printed Demoboard

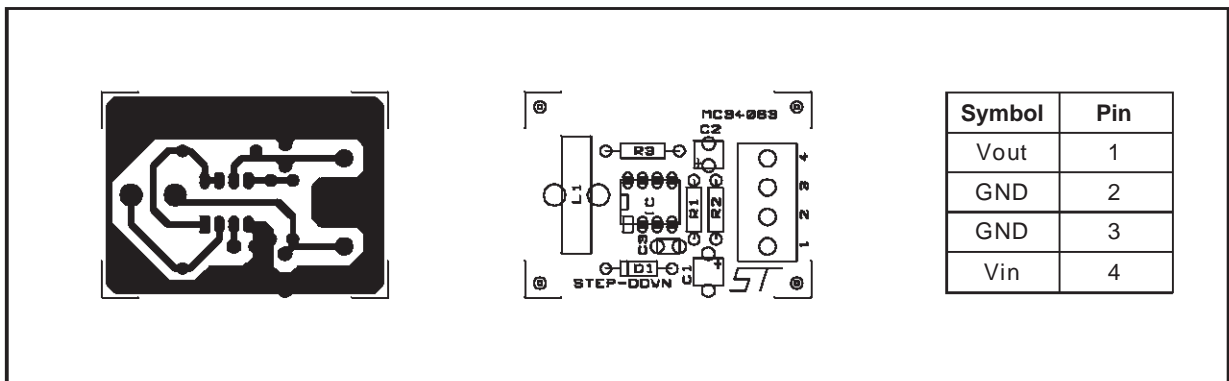

Test Condition ($V_{OUT} = 5V$)

Test	Conditions	Value (Typ.)	Unit
Line Regulation	$V_{IN} = 15 \text{ to } 25V, I_O = 500 \text{ mA}$	5	mV
Load Regulation	$V_{IN} = 25V, I_O = 50 \text{ to } 500 \text{ mA}$	30	mV
Output Ripple	$V_{IN} = 25V, I_O = 500 \text{ mA}$	100	mV
Efficiency	$V_{IN} = 25V, I_O = 500 \text{ mA}$	80	%
I_{sc}	$V_{IN} = 25V, R_{LOAD} = 0.1\Omega$	1.2	A

MC34063A/E

Voltage Inverting Converter

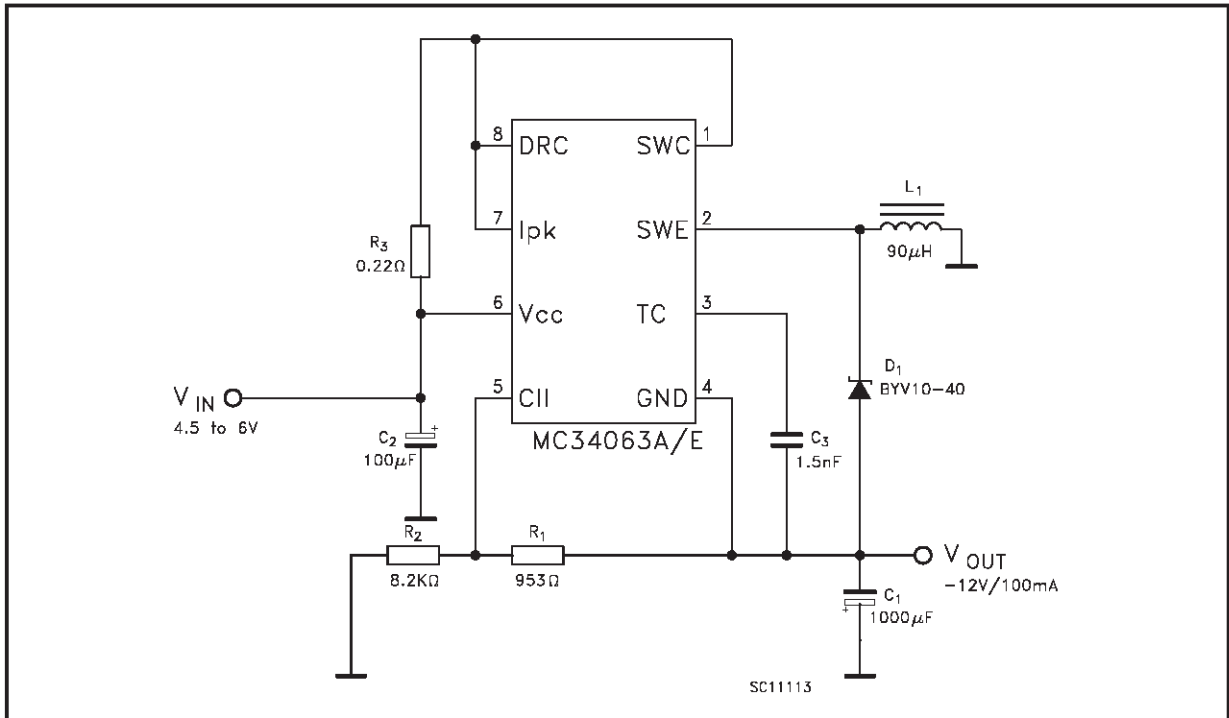

Printed Demoboard

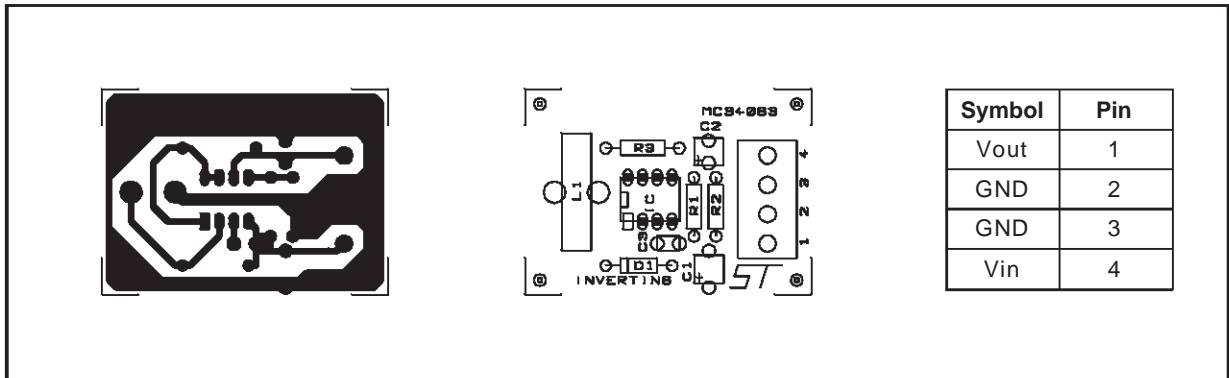

Test Condition (V_{OUT} = -12V)

Test	Conditions	Value (Typ.)	Unit
Line Regulation	V _{IN} = 4.5 to 6V, I _O = 100 mA	15	mV
Load Regulation	V _{IN} = 5V, I _O = 10 to 100 mA	20	mV
Output Ripple	V _{IN} = 5V, I _O = 100 mA	230	mV
Efficiency	V _{IN} = 5V, I _O = 100 mA	58	%
I _{sc}	V _{IN} = 5V, R _{LOAD} = 0.1Ω	0.9	A

Calculation

Parameter	Step-Up (Discontinuos mode)	Step-Down (Continuos mode)	Voltage Inverting (Discontinuos mode)
t_{on}/t_{off}	$\frac{V_{out} + V_F - V_{in(min)}}{V_{in(min)} - V_{sat}}$	$\frac{V_{out} + V_F}{V_{in(min)} - V_{sat} - V_{out}}$	$\frac{ V_{out} + V_F}{V_{in} - V_{sat}}$
$(t_{on} + t_{off})_{max}$	$1/f_{min}$	$1/f_{min}$	$1/f_{min}$
C_T	$4.5 \times 10^{-5} t_{on}$	$4.5 \times 10^{-5} t_{on}$	$4.5 \times 10^{-5} t_{on}$
$I_{PK(switch)}$	$2I_{out(max)}[(t_{on}/t_{off}) + 1]$	$2I_{out(max)}$	$2I_{out(max)}[(t_{on}/t_{off}) + 1]$
R_{sc}	$0.3/I_{PK(switch)}$	$0.3/I_{PK(switch)}$	$0.3/I_{PK(switch)}$
C_o	$\cong \frac{I_{out} t_{on}}{V_{ripple(p-p)}}$	$\frac{I_{PK(switch)} (t_{on} + t_{off})}{8V_{ripple(p-p)}}$	$\cong \frac{I_{out} t_{on}}{V_{ripple(p-p)}}$
$L(min)$	$\frac{V_{in(min)} - V_{sat}}{I_{PK(switch)}} t_{on(max)}$	$\frac{V_{in(min)} - V_{sat} - V_{out}}{I_{PK(switch)}} t_{on(max)}$	$\frac{V_{in(min)} - V_{sat}}{I_{PK(switch)}} t_{on(max)}$

NOTES:

V_{sat} = Saturation voltage of the output switch

V_F = Foward voltage drop of the output rectifier

THE FOLLOWING POWER SUPPLY CHARACTERISTICS MUST BE CHOSEN:

V_{in} = Nominal input voltage

V_{out} = Desired output voltage, $|V_{out}| = 1.25(1 + R_2/R_1)$

I_{out} = Desired output current

f_{min} = Minimum desired output switching frequency at the selected values of V_{in} and I_o

V_{ripple} = Desired peak to peak output ripple voltage. In practice, the calculaed capacitor value will and to be increased due to its equivalent series resistance and board layout. The ripple voltage should be kept to a low value since it will directly affect the line and load regulation.

Step-up With External NPN Switch

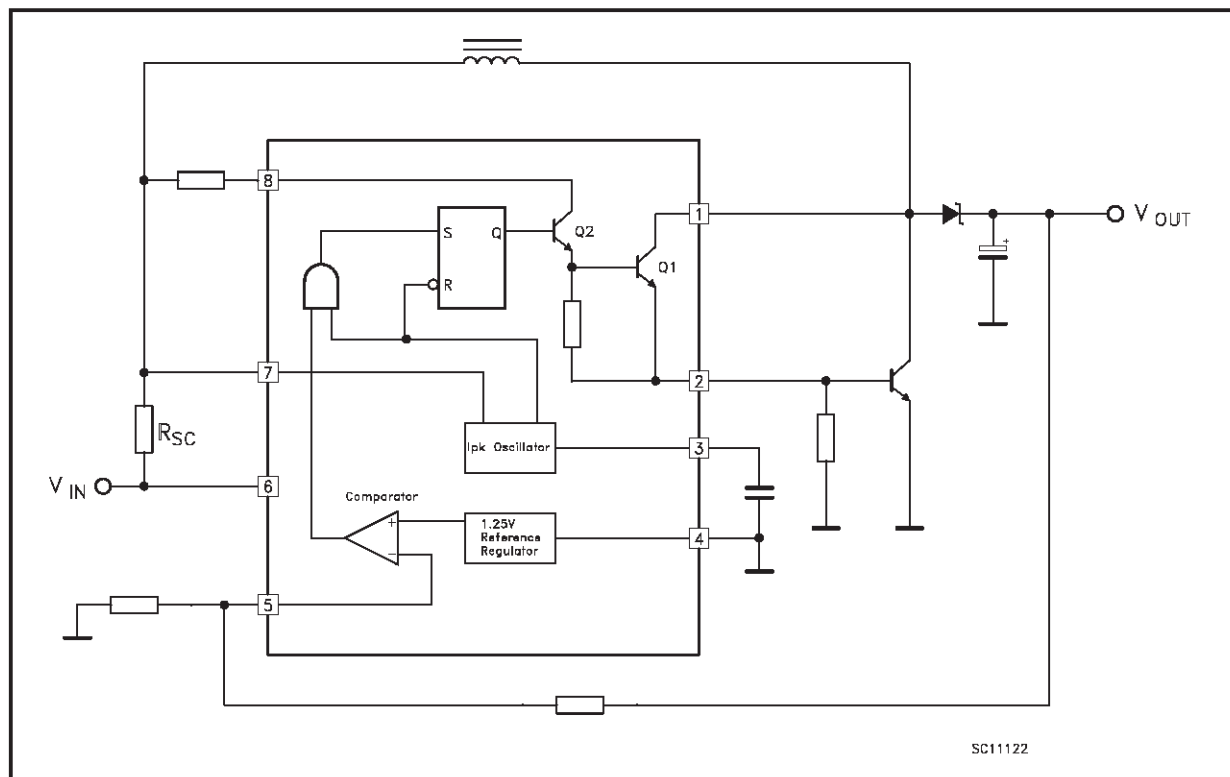

Step-down With External NPN Switch

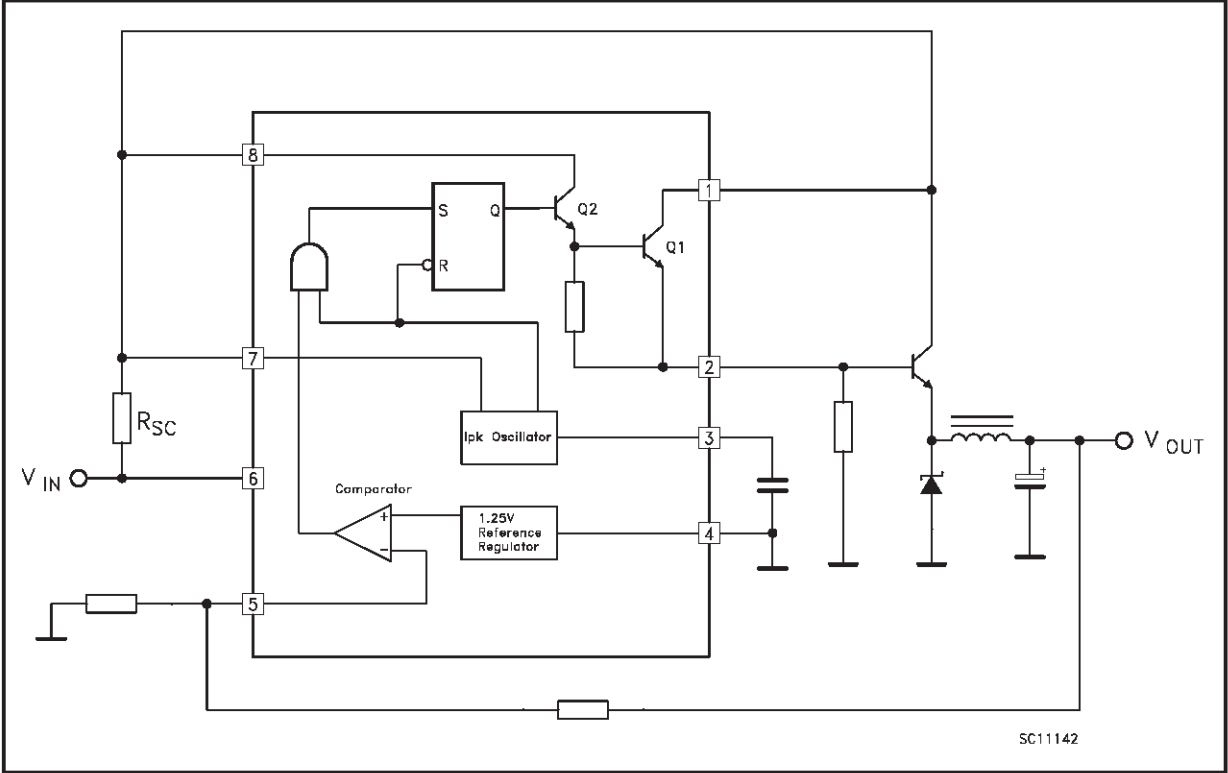

Step-down With External PNP Switch

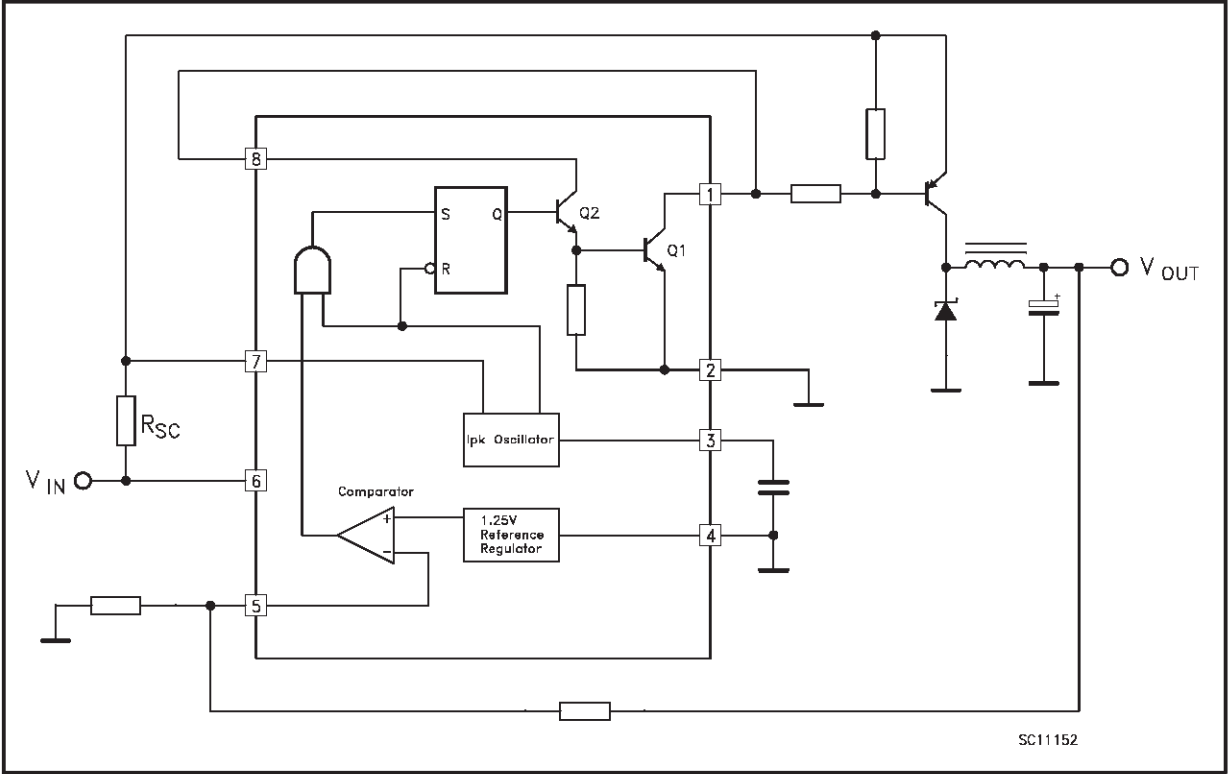

Voltage Inverting With External NPN Switch

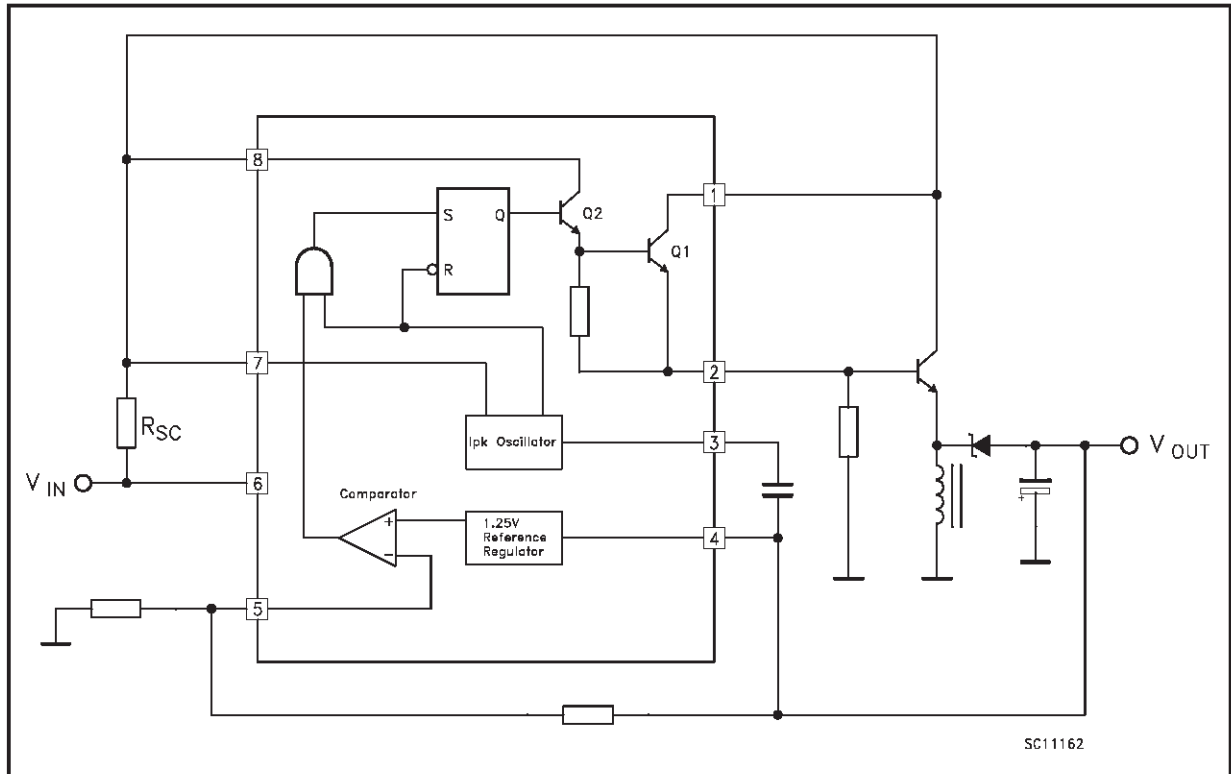

Voltage Inverting With External PNP Saturated Switch

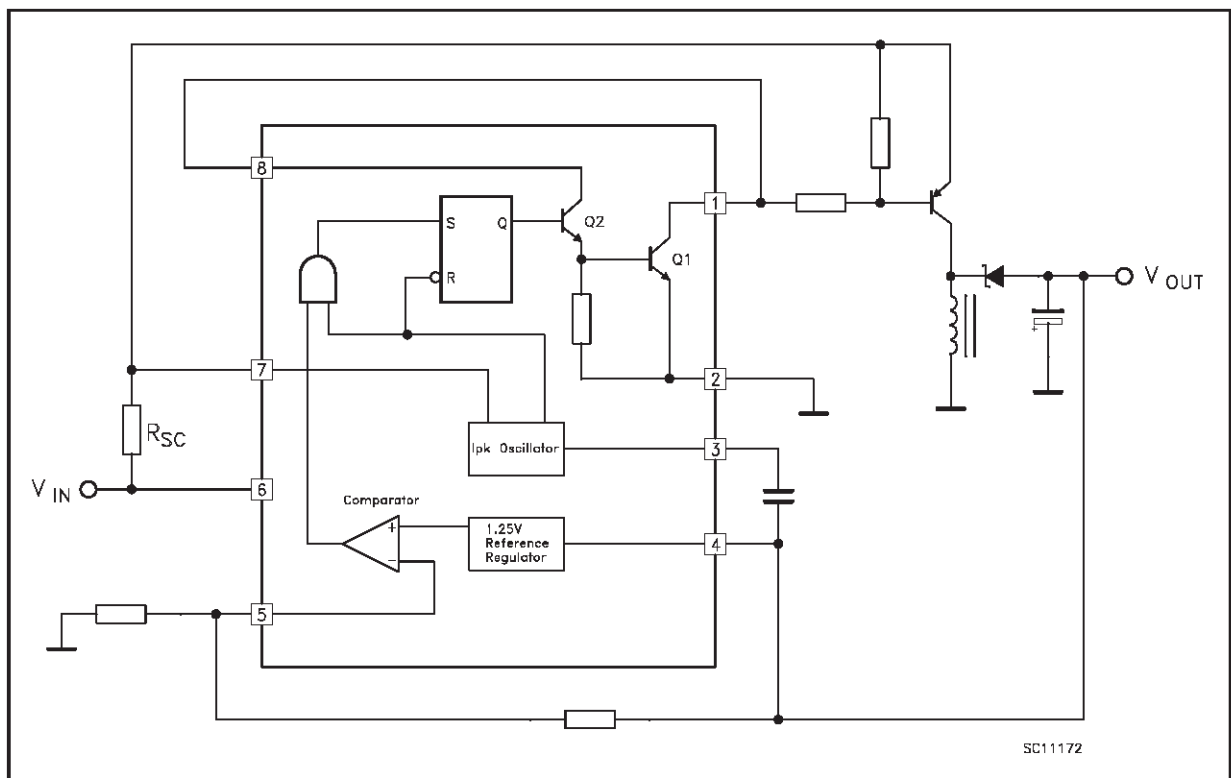

Dual Output Voltage

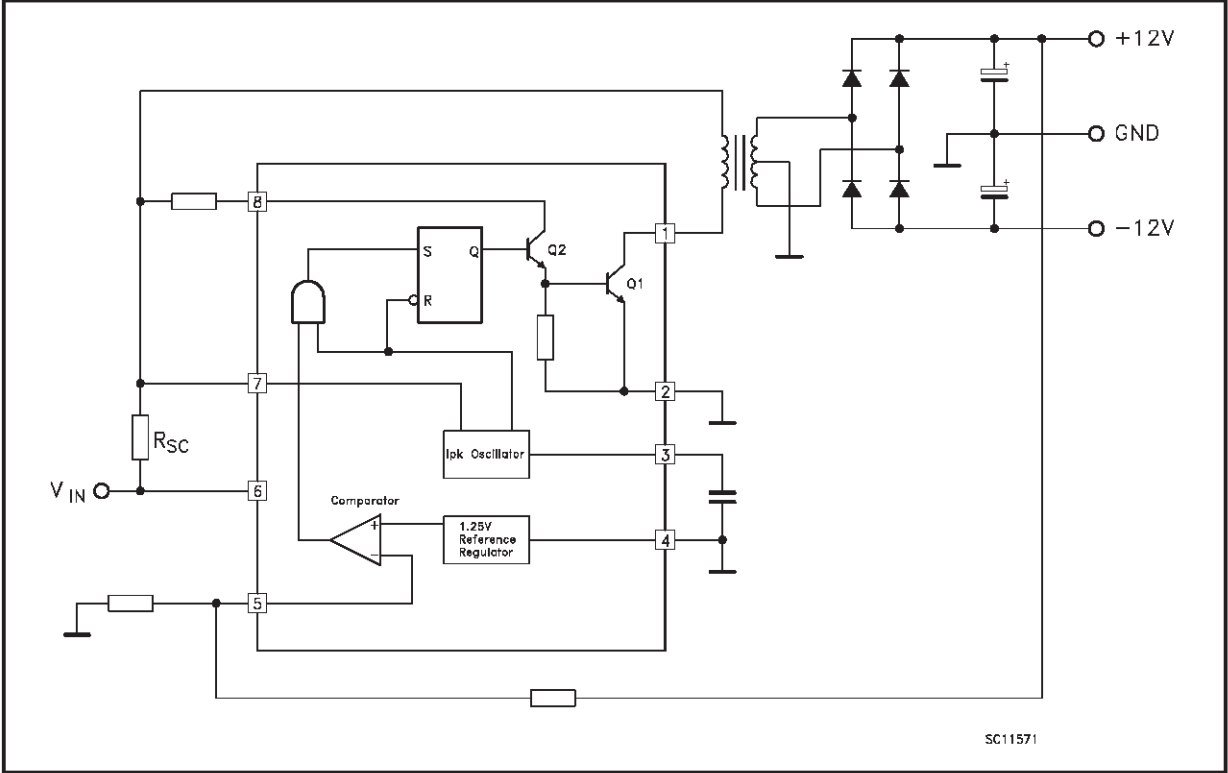

Higher Output Power, Higher Input Voltage

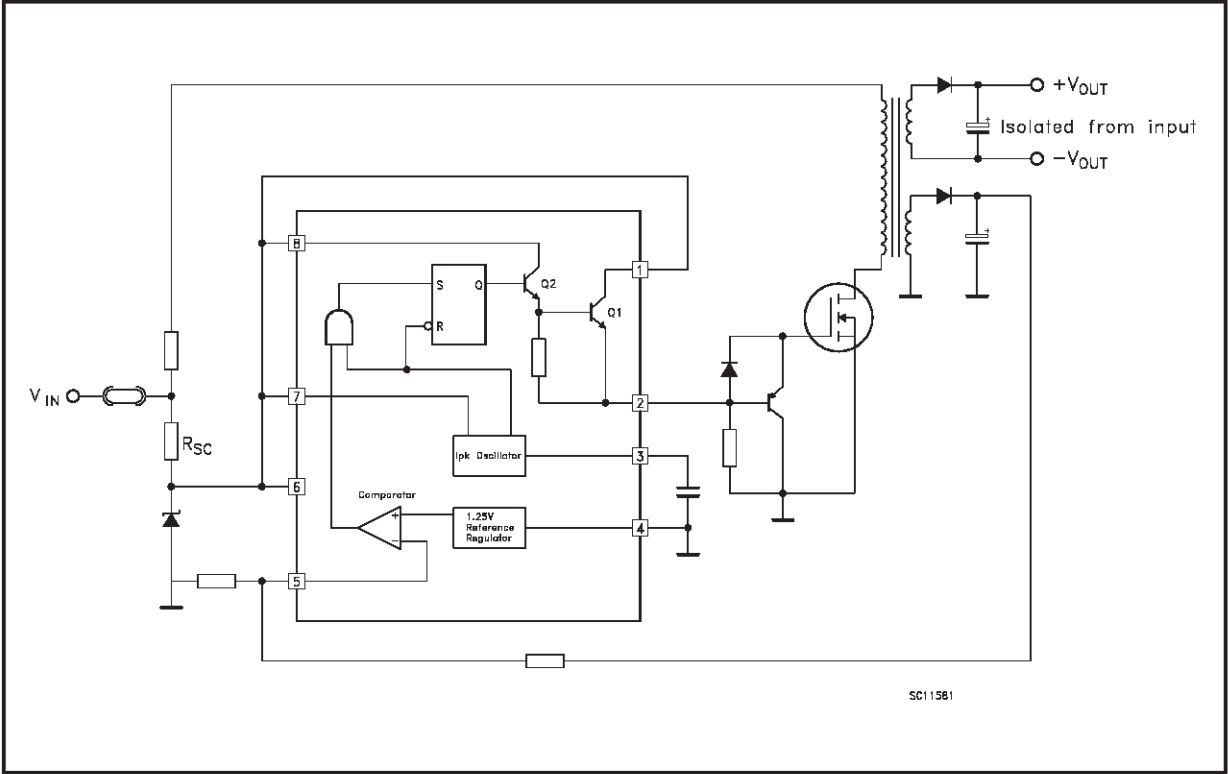

Plastic DIP-8 MECHANICAL DATA

DIM.	mm			inch		
	MIN.	TYP.	MAX.	MIN.	TYP.	MAX.
A		3.3			0.130	
a1	0.7			0.028		
B	1.39		1.65	0.055		0.065
B1	0.91		1.04	0.036		0.041
b		0.5			0.020	
b1	0.38		0.5	0.015		0.020
D			9.8			0.386
E		8.8			0.346	
e		2.54			0.100	
e3		7.62			0.300	
e4		7.62			0.300	
F			7.1			0.280
I			4.8			0.189
L		3.3			0.130	
Z	0.44		1.6	0.017		0.063

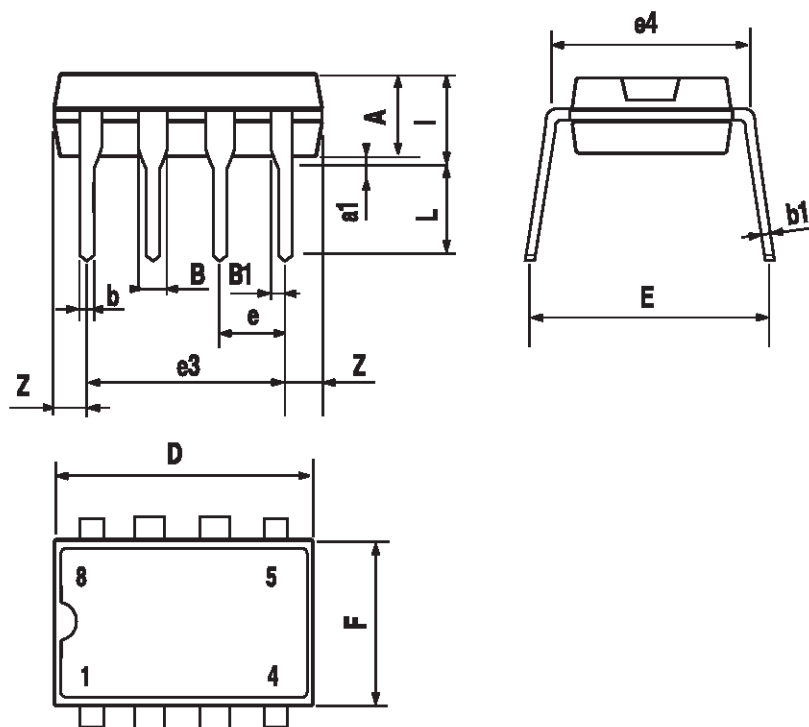

P001F

SO-8 MECHANICAL DATA

DIM.	mm			inch		
	MIN.	TYP.	MAX.	MIN.	TYP.	MAX.
A			1.75			0.068
a1	0.1		0.25	0.003		0.009
a2			1.65			0.064
a3	0.65		0.85	0.025		0.033
b	0.35		0.48	0.013		0.018
b1	0.19		0.25	0.007		0.010
C	0.25		0.5	0.010		0.019
c1	45 (typ.)					
D	4.8		5.0	0.188		0.196
E	5.8		6.2	0.228		0.244
e		1.27			0.050	
e3		3.81			0.150	
F	3.8		4.0	0.14		0.157
L	0.4		1.27	0.015		0.050
M			0.6			0.023
S	8 (max.)					

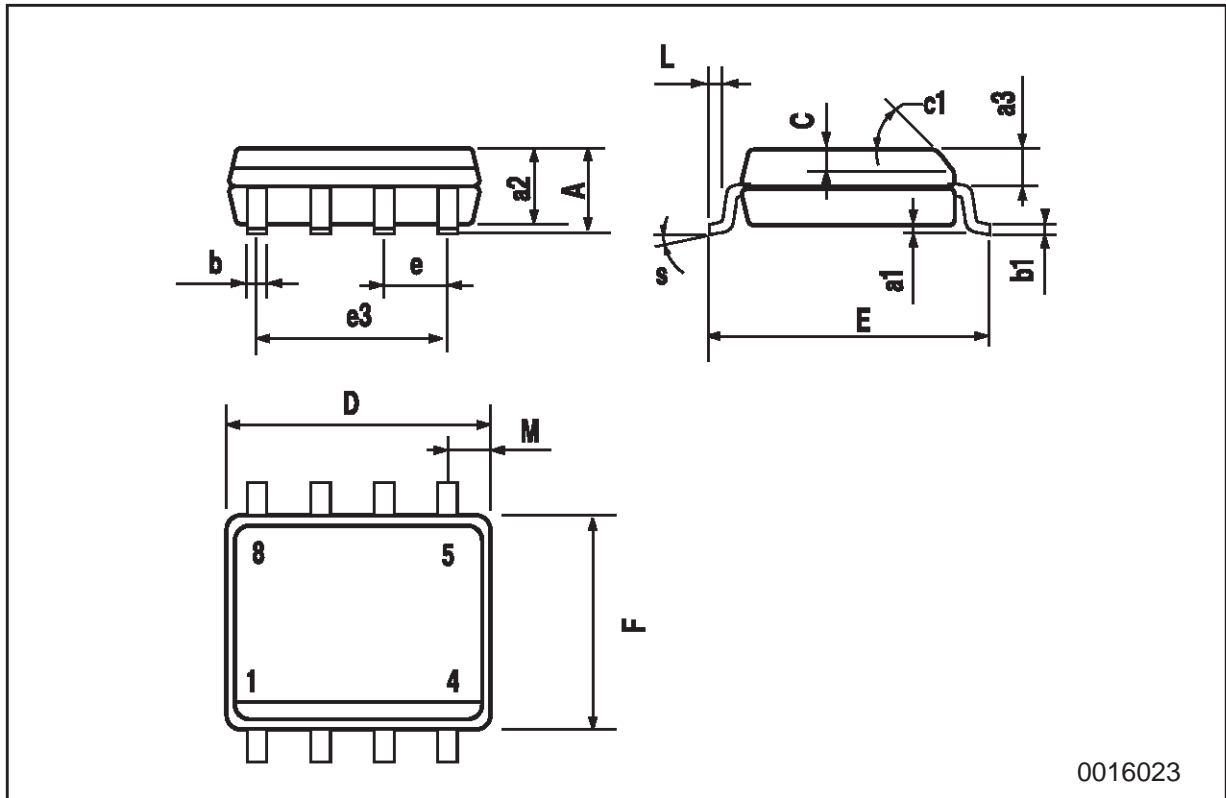

0016023

Information furnished is believed to be accurate and reliable. However, STMicroelectronics assumes no responsibility for the consequences of use of such information nor for any infringement of patents or other rights of third parties which may result from its use. No license is granted by implication or otherwise under any patent or patent rights of STMicroelectronics. Specification mentioned in this publication are subject to change without notice. This publication supersedes and replaces all information previously supplied. STMicroelectronics products are not authorized for use as critical components in life support devices or systems without express written approval of STMicroelectronics.

The ST logo is a registered trademark of STMicroelectronics

© 2001 STMicroelectronics – Printed in Italy – All Rights Reserved
STMicroelectronics GROUP OF COMPANIES

Australia - Brazil - China - Finland - France - Germany - Hong Kong - India - Italy - Japan - Malaysia - Malta - Morocco
Singapore - Spain - Sweden - Switzerland - United Kingdom - U.S.A.

<http://www.st.com>