



# LD1117A SERIES

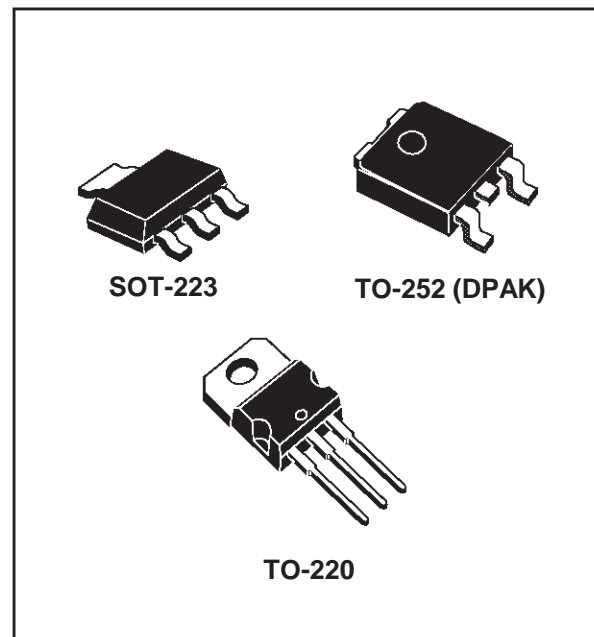
## LOW DROP FIXED AND ADJUSTABLE POSITIVE VOLTAGE REGULATORS

PRELIMINARY DATA

- LOW DROPOUT VOLTAGE  
(1.15V TYP @  $I_{OUT}=1A$ , 25°C)
- VERY LOW QUIESCENT CURRENT  
(5mA TYP @ 25°C)
- TYPE A: OUTPUT CURRENT UP TO 1A
- FIXED OUTPUT VOLTAGE OF: 1.8V, 2.5V,  
2.85V, 3.3V, 5.0V
- ADJUSTABLE VERSION AVAILABILITY  
( $V_{REF}=1.25V$ )
- INTERNAL CURRENT AND THERMAL LIMIT
- ONLY 10  $\mu F$  FOR STABILITY
- AVAILABLE IN  $\pm 2\%$  (AT 25°C) AND 4% IN  
FULL TEMPERATURE RANGE
- HIGH SUPPLY VOLTAGE REJECTION :  
(80dB TYP AT 25°C)
- TEMPERATURE RANGE : 0°C TO 125°C

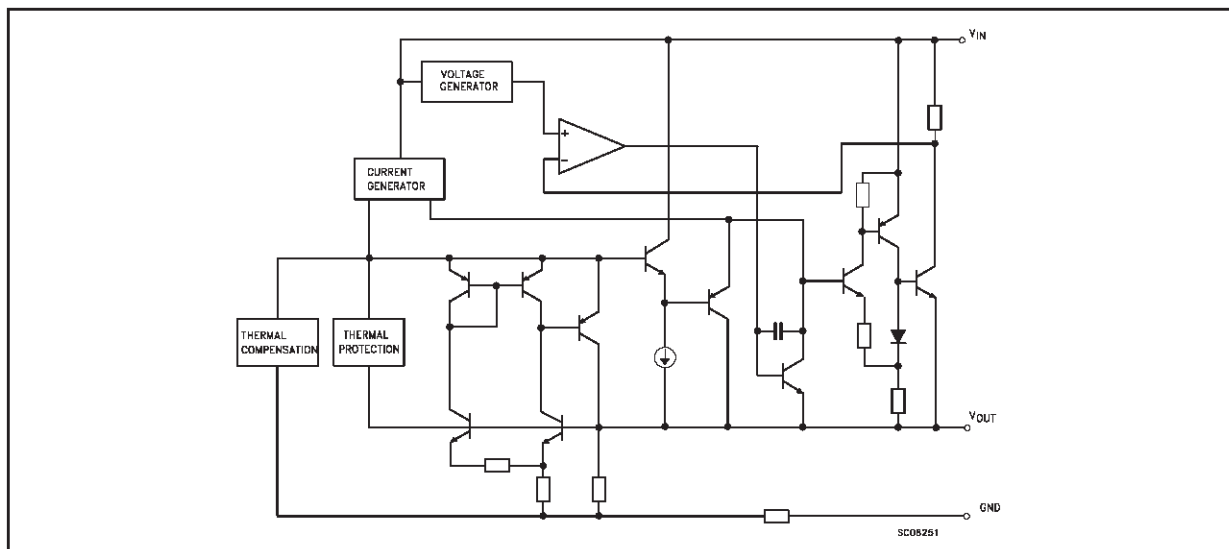
### DESCRIPTION

The LD1117A is a LOW DROP Voltage Regulator able to provide up to 1A of Output Current, available even in adjustable version ( $V_{REF}=1.25V$ ). Concerning fixed versions, are offered the following Output Voltages: 1.8V, 2.5V, 2.85V, 3.3V and 5.0V. The 2.85V type is ideal for SCSI-2 lines active termination. The device is supplied in: SOT-223, DPAK, TO-220. The surface mount packages optimize the thermal characteristics even offering a relevant



space saving effect. High efficiency is assured by NPN pass transistor. Only a very common 10 $\mu F$  minimum capacitor is needed for stability. Only chip trimming allows the regulator to reach a very tight output voltage tolerance, within  $\pm 2\%$  at 25°C

### BLOCK DIAGRAM



## LD1117A SERIES

### ABSOLUTE MAXIMUM RATINGS

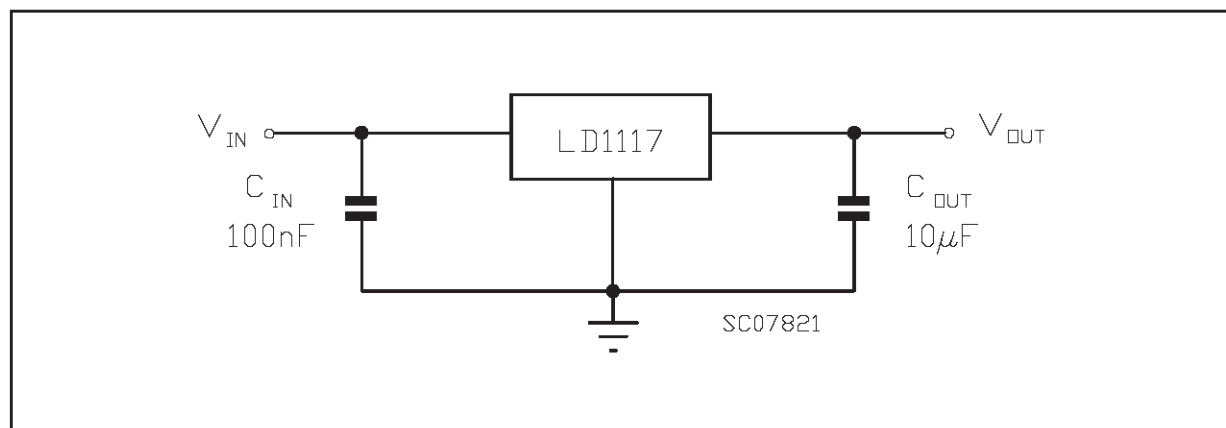
Symbol	Parameter	Value	Unit
$V_{IN}$	DC Input Voltage	10	V
$P_{tot}$	Power Dissipation	12	W
$T_{stg}$	Storage Temperature Range	-40 to 150	°C
$T_{op}$	Operating Junction Temperature Range	0 to 125	°C

Absolute Maximum Ratings are those value beyond which damage to the device may occur. Functional operation under these condition is not implied. Over the above suggested Max Power Dissipation a Short Circuit could definitively damage the device.

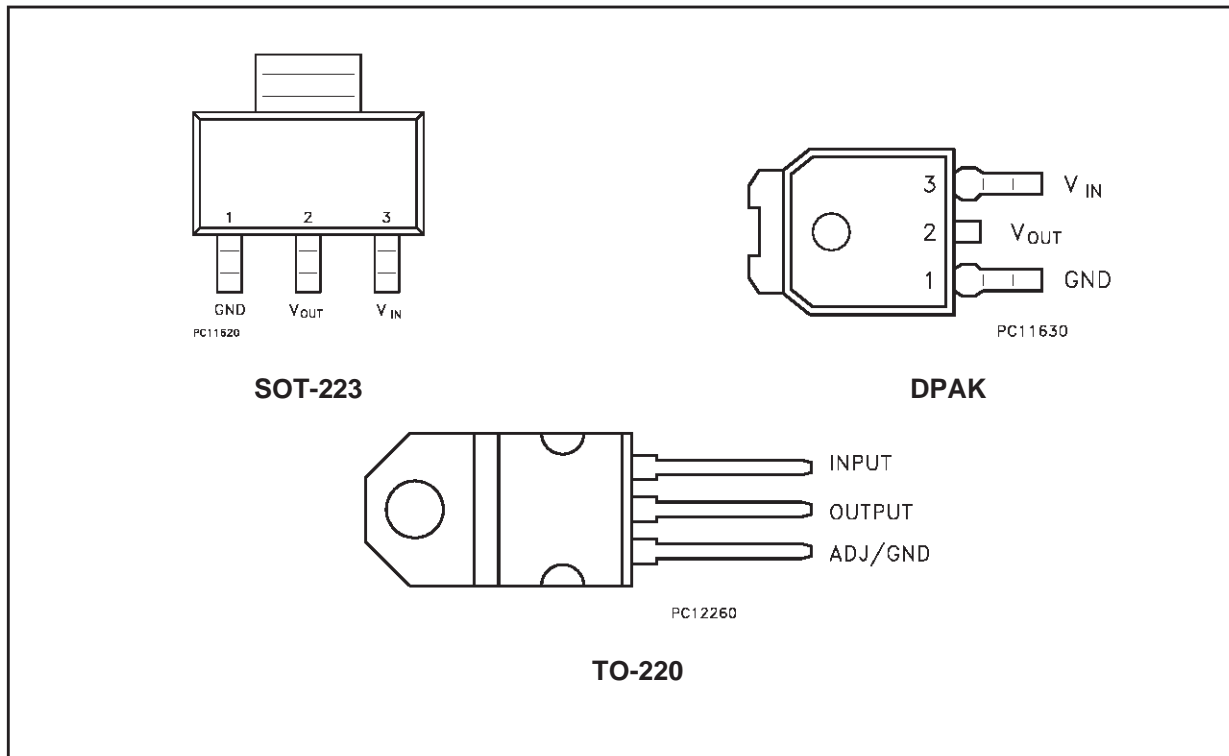
### THERMAL DATA

Symbol	Parameter	TO-220	SOT-223	DKPAK	Unit
$R_{thj-case}$	Thermal Resistance Junction-case	3	15	8	°C/W
$R_{thj-amb}$	Thermal Resistance Junction-ambient	50			°C/W

### APPLICATION CIRCUIT



CONNECTION DIAGRAM AND ORDERING NUMBERS (top view)



SOT-223	DPAK	TO-220	Output Voltage
LD1117AS18TR	LD1117ADT18TR	LD1117AV18	1.8V
LD1117AS25TR	LD1117ADT25TR	LD1117AV25	2.5V
LD1117AS28TR	LD1117ADT28TR	LD1117AV28	2.85V
LD1117AS33TR	LD1117ADT33TR	LD1117AV33	3.3V
LD1117AS50TR	LD1117ADT50TR	LD1117AV50	5V
LD1117AST-R	LD1117ADT-R	LD1117AV	ADJUSTABLE FROM 1.25 TO 15V

## LD1117A SERIES

**ELECTRICAL CHARACTERISTICS FOR LD1117A#18** (refer to the test circuits,  
 $T_j = 0$  to  $125$  °C,  $C_O = 10$   $\mu$ F,  $C_I = 10$   $\mu$ F unless otherwise specified)

Symbol	Parameter	Test Conditions	Min.	Typ.	Max.	Unit
$V_O$	Output Voltage	$V_I = 3.8$ V $I_O = 10$ mA $T_j = 25$ °C	1.764	1.8	1.836	V
$V_O$	Output Voltage	$I_O = 0$ to 1000 mA $V_I = 3.3$ to 8 V	1.728		1.872	V
$\Delta V_O$	Line Regulation	$V_I = 3.3$ to 8 V $I_O = 0$ mA		1	6	mV
$\Delta V_O$	Load Regulation	$V_I = 3.3$ V $I_O = 0$ to 1000 mA		1	10	mV
$V_I$	Operating Input Voltage	$I_O = 100$ mA			10	V
$I_d$	Quiescent Current	$V_I \leq 8$ V $I_O = 0$ mA		5	10	mA
$I_O$	Output Current	$V_I - V_O = 5$ V $T_j = 25$ °C	1000			mA
SVR	Supply Voltage Rejection	$I_O = 40$ mA $f = 120$ Hz $V_I - V_O = 3$ V $V_{ripple} = 1$ Vpp	60	80		dB
$V_D$	Dropout Voltage	$I_O = 100$ mA $I_O = 500$ mA $I_O = 1000$ mA		1 1.05 1.15	1.10 1.15 1.30	V V V
$\Delta V_{O(pwr)}$	Thermal Regulation	$T_a = 25$ °C 30ms Pulse		0.08	0.2	%/W

**ELECTRICAL CHARACTERISTICS FOR LD1117A#25** (refer to the test circuits,  
 $T_j = 0$  to  $125$  °C,  $C_O = 10$   $\mu$ F,  $C_I = 10$   $\mu$ F unless otherwise specified)

Symbol	Parameter	Test Conditions	Min.	Typ.	Max.	Unit
$V_O$	Output Voltage	$V_I = 4.5$ V $I_O = 10$ mA $T_j = 25$ °C	2.45	2.5	2.55	V
$V_O$	Output Voltage	$I_O = 0$ to 1000 mA $V_I = 3.9$ to 8 V	2.4		2.6	V
$\Delta V_O$	Line Regulation	$V_I = 3.9$ to 8 V $I_O = 0$ mA		1	6	mV
$\Delta V_O$	Load Regulation	$V_I = 3.9$ V $I_O = 0$ to 1000 mA		1	10	mV
$V_I$	Operating Input Voltage	$I_O = 100$ mA			10	V
$I_d$	Quiescent Current	$V_I \leq 10$ V $I_O = 0$ mA		5	10	mA
$I_O$	Output Current	$V_I - V_O = 5$ V $T_j = 25$ °C	1000	1200		mA
SVR	Supply Voltage Rejection	$I_O = 40$ mA $f = 120$ Hz $V_I - V_O = 3$ V $V_{ripple} = 1$ Vpp	60	80		dB
$V_D$	Dropout Voltage	$I_O = 100$ mA $I_O = 500$ mA $I_O = 1000$ mA		1 1.05 1.15	1.10 1.15 1.30	V V V
$\Delta V_{O(pwr)}$	Thermal Regulation	$T_a = 25$ °C 30ms Pulse		0.08	0.2	%/W

**ELECTRICAL CHARACTERISTICS FOR LD1117A#28** (refer to the test circuits,  
 $T_j = 0$  to  $125$  °C,  $C_O = 10$   $\mu$ F,  $C_I = 10$   $\mu$ F unless otherwise specified)

Symbol	Parameter	Test Conditions	Min.	Typ.	Max.	Unit
$V_O$	Output Voltage	$V_I = 4.85$ V $I_O = 10$ mA $T_j = 25$ °C	2.793	2.85	2.907	V
$V_O$	Output Voltage	$I_O = 0$ to 1000 mA $V_I = 4.25$ to 10 V	2.736		2.964	V
$\Delta V_O$	Line Regulation	$V_I = 4.25$ to 8 V $I_O = 0$ mA		1	6	mV
$\Delta V_O$	Load Regulation	$V_I = 4.25$ V $I_O = 0$ to 1000 mA		2	10	mV
$V_I$	Operating Input Voltage	$I_O = 100$ mA			10	V
$I_d$	Quiescent Current	$V_I \leq 10$ V $I_O = 0$ mA		4.5	10	mA
$I_O$	Output Current	$V_I - V_O = 5$ V $T_j = 25$ °C	1000	1200		mA
SVR	Supply Voltage Rejection	$I_O = 40$ mA $f = 120$ Hz $V_I - V_O = 3$ V $V_{ripple} = 1$ Vpp	60	75		dB
$V_D$	Dropout Voltage	$I_O = 100$ mA $I_O = 500$ mA $I_O = 1000$ mA		1 1.05 1.15	1.10 1.15 1.30	V V V
$\Delta V_{O(pwr)}$	Thermal Regulation	$T_a = 25$ °C 30ms Pulse		0.08	0.2	%/W

**ELECTRICAL CHARACTERISTICS FOR LD1117A#33** (refer to the test circuits,  
 $T_j = 0$  to  $125$  °C,  $C_O = 10$   $\mu$ F,  $C_I = 10$   $\mu$ F unless otherwise specified)

Symbol	Parameter	Test Conditions	Min.	Typ.	Max.	Unit
$V_O$	Output Voltage	$V_I = 5.3$ V $I_O = 10$ mA $T_j = 25$ °C	3.234	3.3	3.366	V
$V_O$	Output Voltage	$I_O = 0$ to 1000 mA $V_I = 4.75$ to 10 V	3.168		3.432	V
$\Delta V_O$	Line Regulation	$V_I = 4.75$ to 8 V $I_O = 0$ mA		1	6	mV
$\Delta V_O$	Load Regulation	$V_I = 4.75$ V $I_O = 0$ to 1000 mA		1	10	mV
$V_I$	Operating Input Voltage	$I_O = 100$ mA			10	V
$I_d$	Quiescent Current	$V_I \leq 10$ V $I_O = 0$ mA		5	10	mA
$I_O$	Output Current	$V_I - V_O = 5$ V $T_j = 25$ °C	1000	1200		mA
SVR	Supply Voltage Rejection	$I_O = 40$ mA $f = 120$ Hz $V_I - V_O = 3$ V $V_{ripple} = 1$ Vpp	60	75		dB
$V_D$	Dropout Voltage	$I_O = 100$ mA $I_O = 500$ mA $I_O = 1000$ mA		1 1.05 1.15	1.10 1.15 1.30	V V V
$\Delta V_{O(pwr)}$	Thermal Regulation	$T_a = 25$ °C 30ms Pulse		0.08	0.2	%/W

## LD1117A SERIES

**ELECTRICAL CHARACTERISTICS FOR LD1117A#50** (refer to the test circuits,  
 $T_j = 0$  to  $125\text{ }^\circ\text{C}$ ,  $C_O = 10\text{ }\mu\text{F}$ ,  $C_I = 10\text{ }\mu\text{F}$  unless otherwise specified)

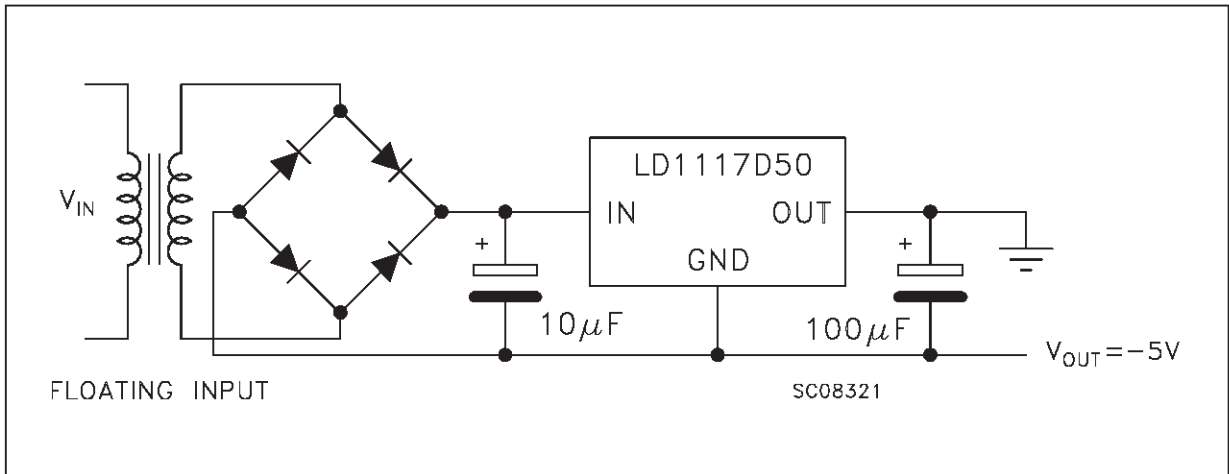
Symbol	Parameter	Test Conditions	Min.	Typ.	Max.	Unit
$V_O$	Output Voltage	$V_I = 7\text{ V}$ $I_O = 10\text{ mA}$ $T_j = 25\text{ }^\circ\text{C}$	4.9	5	5.1	V
$V_O$	Output Voltage	$I_O = 0$ to $1000\text{ mA}$ $V_I = 6.4$ to $10\text{ V}$	4.8		5.2	V
$\Delta V_O$	Line Regulation	$V_I = 6.4$ to $8\text{ V}$ $I_O = 0\text{ mA}$		1	6	mV
$\Delta V_O$	Load Regulation	$V_I = 6.4\text{ V}$ $I_O = 0$ to $1000\text{ mA}$		1	10	mV
$V_I$	Operating Input Voltage	$I_O = 100\text{ mA}$			10	V
$I_d$	Quiescent Current	$V_I \leq 10\text{ V}$ $I_O = 0\text{ mA}$		5	10	mA
$I_O$	Output Current	$V_I - V_O = 5\text{ V}$ $T_j = 25\text{ }^\circ\text{C}$	1000	1200		mA
SVR	Supply Voltage Rejection	$I_O = 40\text{ mA}$ $f = 120\text{ Hz}$ $V_I - V_O = 3\text{ V}$ $V_{\text{ripple}} = 1\text{ V}_{\text{pp}}$	60	80		dB
$V_D$	Dropout Voltage	$I_O = 100\text{ mA}$ $I_O = 500\text{ mA}$ $I_O = 1000\text{ mA}$		1 1.05 1.15	1.10 1.15 1.30	V V V
$\Delta V_{O(\text{pwr})}$	Thermal Regulation	$T_a = 25\text{ }^\circ\text{C}$ 30ms Pulse		0.08	0.2	%/W

**ELECTRICAL CHARACTERISTICS FOR LD1117ADJ** (refer to the test circuits,  
 $T_j = 0$  to  $125\text{ }^\circ\text{C}$ ,  $C_O = 10\text{ }\mu\text{F}$ ,  $C_I = 10\text{ }\mu\text{F}$  unless otherwise specified)

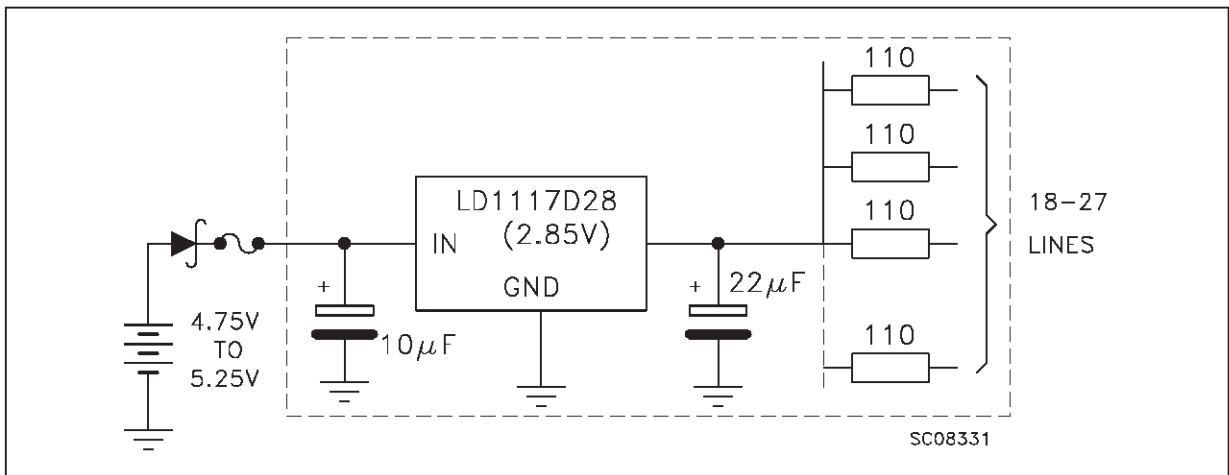
Symbol	Parameter	Test Conditions	Min.	Typ.	Max.	Unit
$V_O$	Output Voltage	$V_I = 5.3\text{ V}$ $I_O = 10\text{ mA}$ $T_j = 25\text{ }^\circ\text{C}$	1.225	1.25	1.275	V
$V_O$	Output Voltage	$I_O = 0$ to $1000\text{ mA}$ $V_I = 2.75$ to $10\text{ V}$	1.2		1.3	V
$\Delta V_O$	Line Regulation	$V_I = 2.75$ to $10\text{ V}$ $I_O = 0\text{ mA}$		1	6	mV
$\Delta V_O$	Load Regulation	$V_I = 2.75\text{ V}$ $I_O = 0$ to $1000\text{ mA}$		1	10	mV
$V_I$	Operating Input Voltage	$I_O = 100\text{ mA}$			10	V
$I_d$	Quiescent Current	$V_I \leq 8\text{ V}$ $I_O = 0\text{ mA}$		5	10	mA
$I_O$	Output Current	$V_I - V_O = 5\text{ V}$ $T_j = 25\text{ }^\circ\text{C}$	1000	1200		mA
SVR	Supply Voltage Rejection	$I_O = 40\text{ mA}$ $f = 120\text{ Hz}$ $V_I - V_O = 3\text{ V}$ $V_{\text{ripple}} = 1\text{ V}_{\text{pp}}$	60	80		dB
$V_D$	Dropout Voltage	$I_O = 100\text{ mA}$ $I_O = 500\text{ mA}$ $I_O = 1000\text{ mA}$		1 1.05 1.15	1.10 1.15 1.30	V V V
$\Delta V_{O(\text{pwr})}$	Thermal Regulation	$T_a = 25\text{ }^\circ\text{C}$ 30ms Pulse		0.08	0.2	%/W

**TYPICAL APPLICATIONS:**

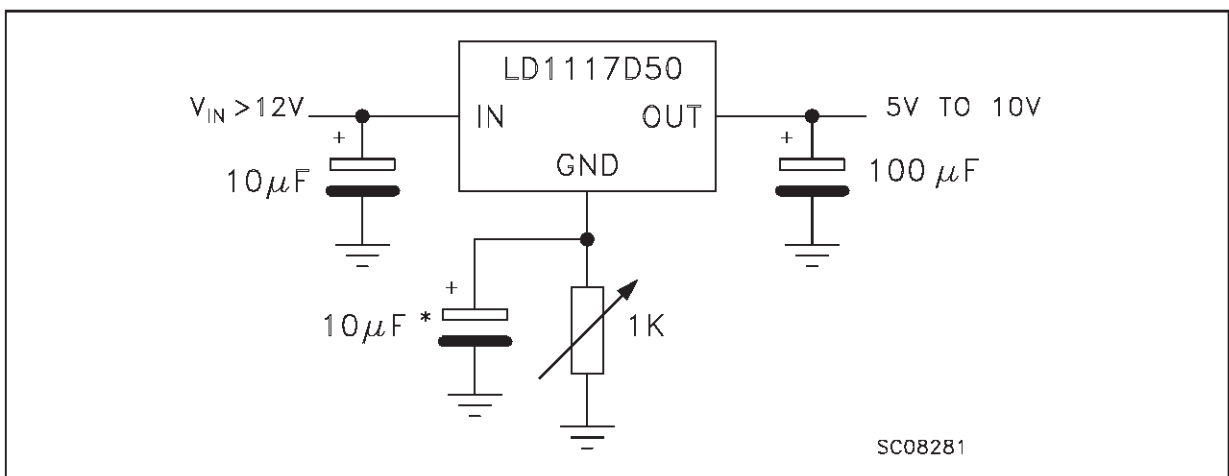
**FIGURE 1: Negative Supply**



**FIGURE 2: Active Terminator for SCSI-2 BUS**



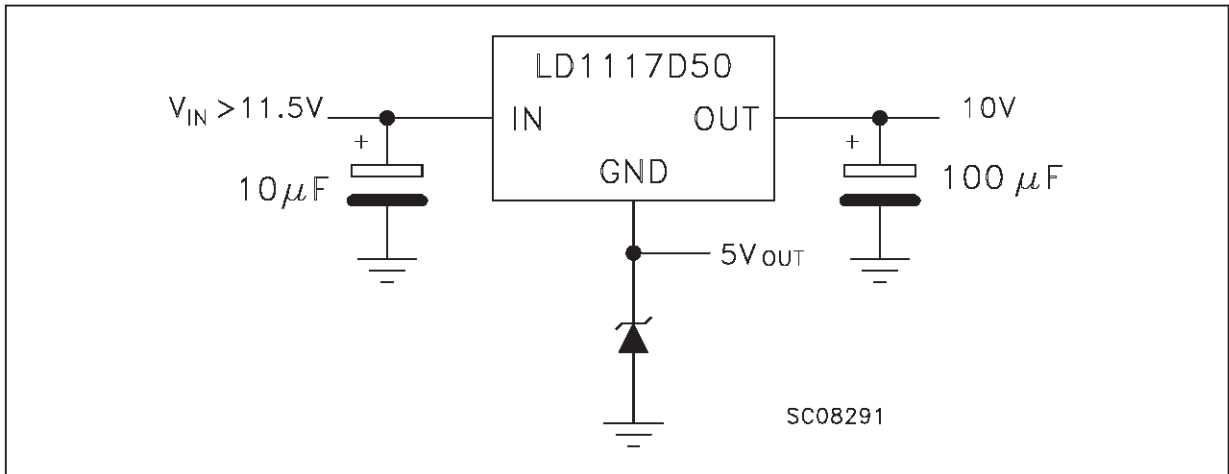
**FIGURE 3: Circuit for Increasing Output Voltage**



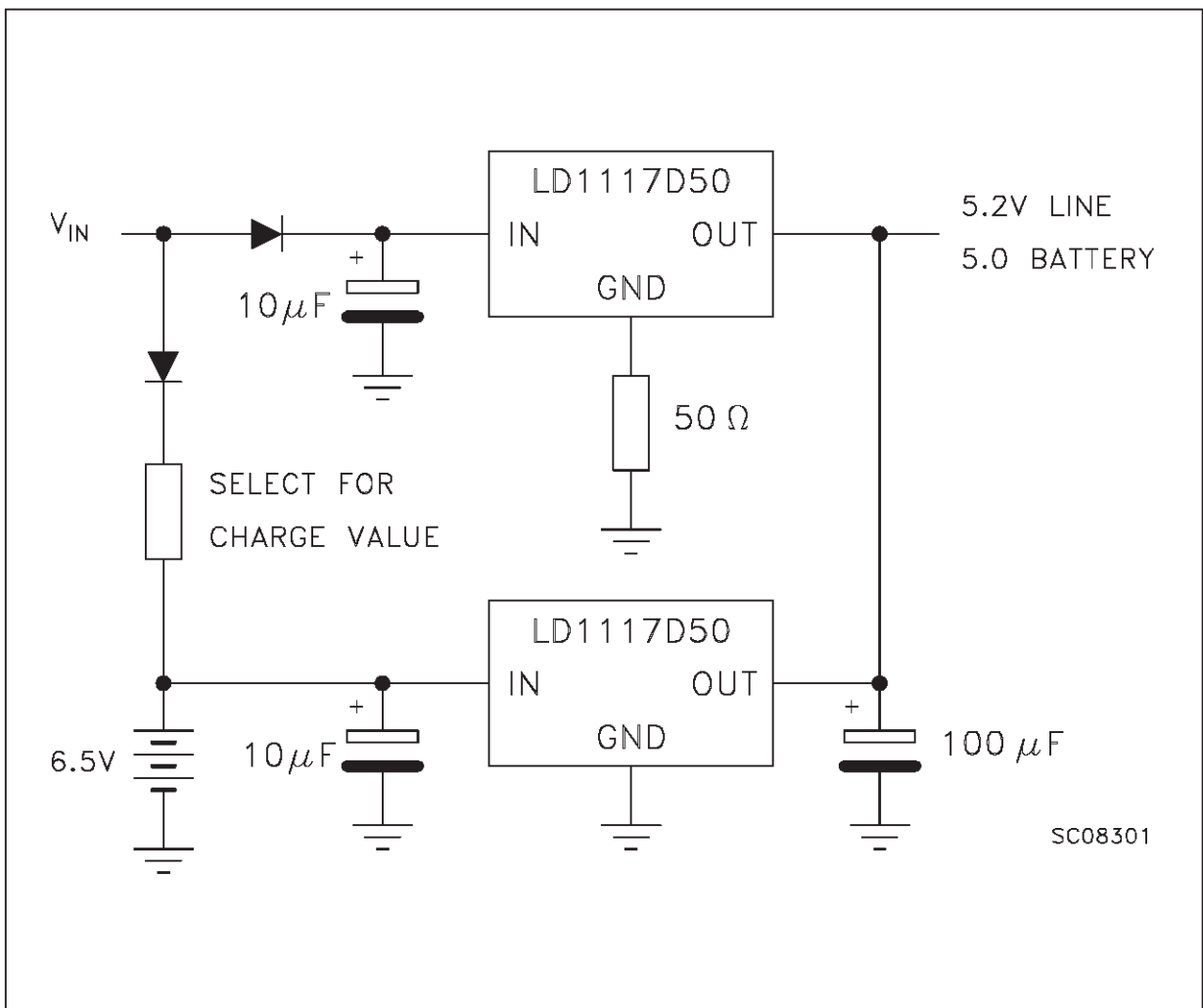
## LD1117A SERIES

### TYPICAL APPLICATIONS (continued):

**FIGURE 4:** Voltage Regulator With Reference

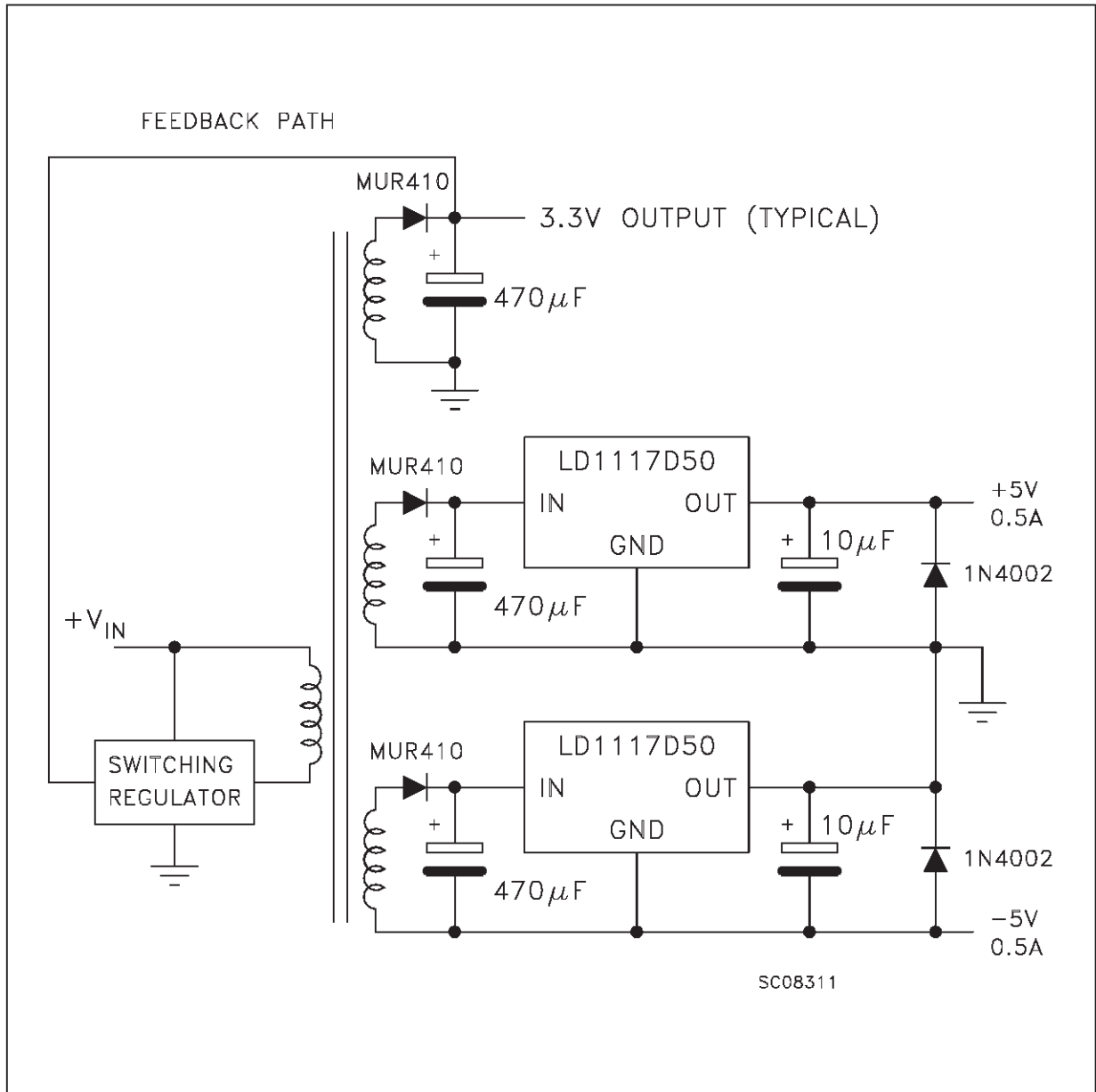


**FIGURE 5:** Battery Backed-up Regulated Supply



TYPICAL APPLICATIONS (continued):

FIGURE 6: Post-Regulated Dual Supply



## LD1117A SERIES

### LD1117 ADJUSTABLE: APPLICATION NOTE

The LD1117 ADJUSTABLE has a thermal stabilized  $1.25 \pm 0.012V$  reference voltage between the OUT and ADJ pins.  $I_{ADJ}$  is  $60\mu A$  typ. ( $120\mu A$  max.) and  $\Delta I_{ADJ}$  is  $1\mu A$  typ. ( $5\mu A$  max.).

$R1$  is normally fixed to  $120\Omega$ . From figure 7 we obtain:

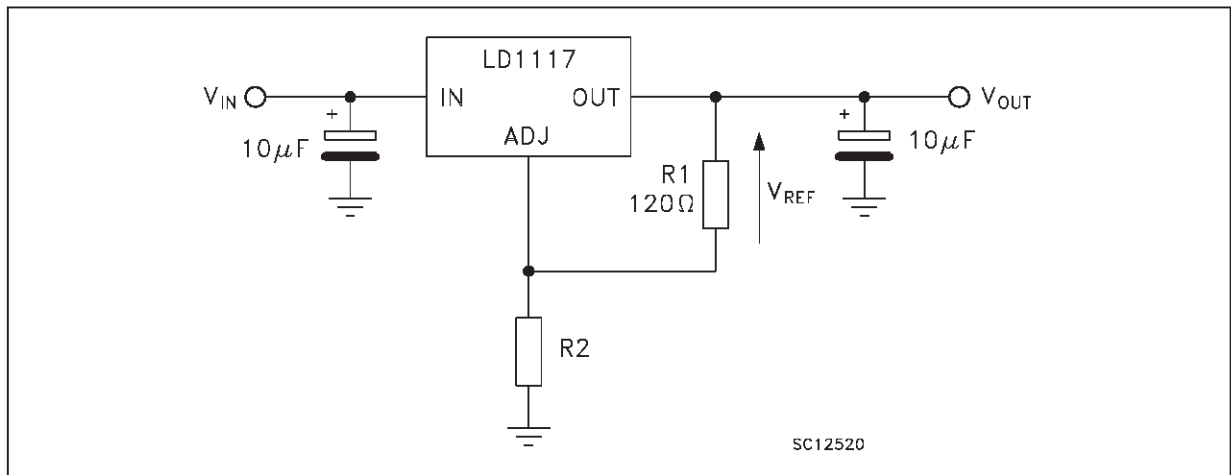
$$V_{OUT} = V_{REF} + R2 (I_{ADJ} + I_{R1}) = V_{REF} + R2 (I_{ADJ} + V_{REF} / R1) = V_{REF} (1 + R2 / R1) + R2 \times I_{ADJ}.$$

In normal application  $R2$  value is in the range of few Kohm, so the  $R2 \times I_{DJ}$  product could not be considered in the  $V_{OUT}$  calculation; then the above expression becomes:

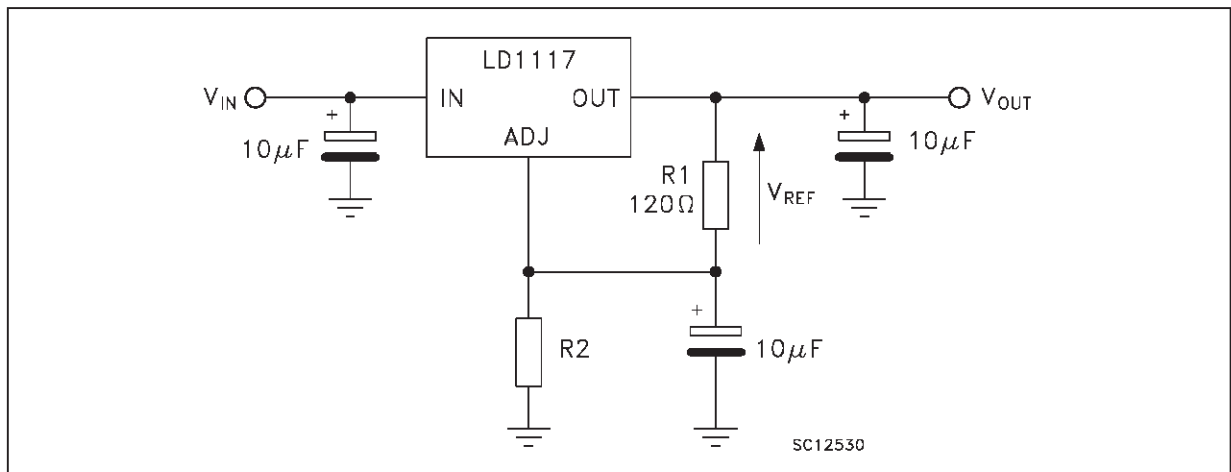
$$V_{OUT} = V_{REF} (1 + R2 / R1).$$

In order to have the better load regulation it is important to realize a good Kelvin connection of  $R1$  and  $R2$  resistors. In particular  $R1$  connection must be realized very close to OUT and ADJ pin, while  $R2$  ground connection must be placed as near as possible to the negative Load pin. Ripple rejection can be improved by introducing a  $10\mu F$  electrolytic capacitor placed in parallel to the  $R2$  resistor (see

**FIGURE 7:** Adjustable Output Voltage Application Circuit

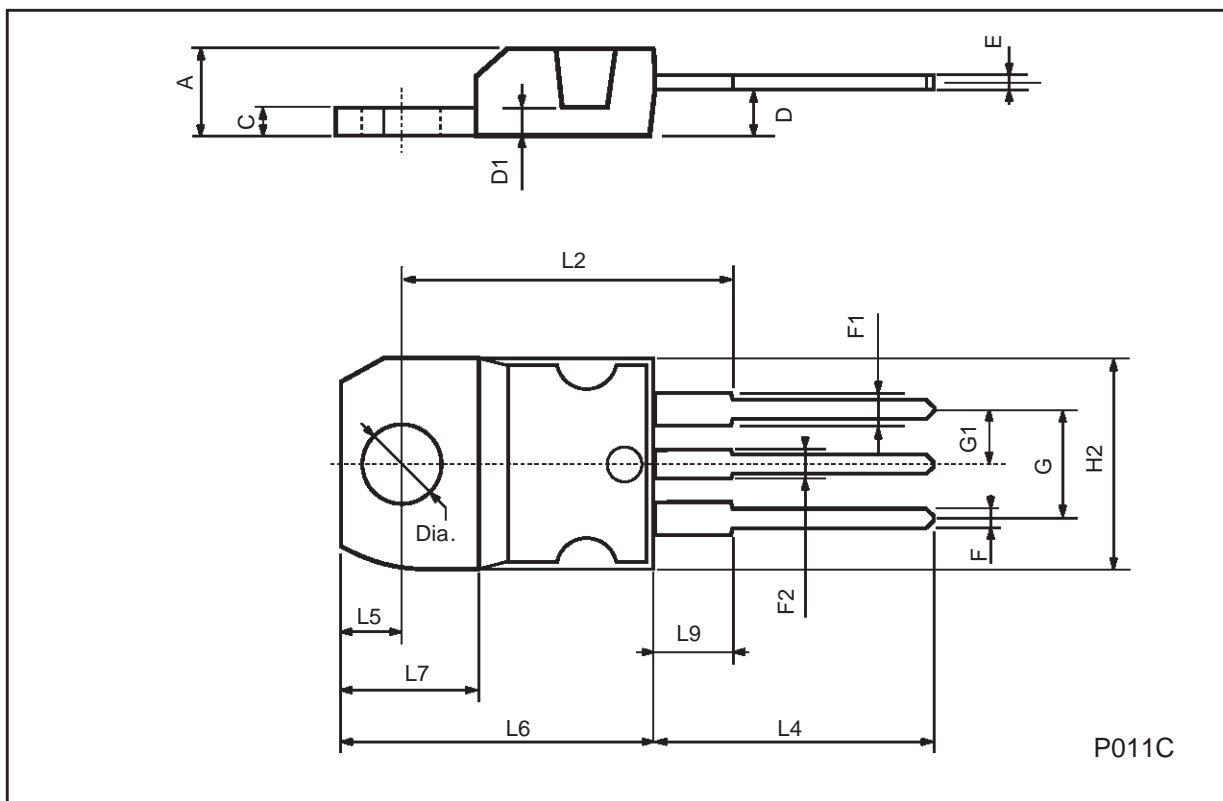


**FIGURE 8:** Adjustable Output Voltage Application with improved Ripple Rejection



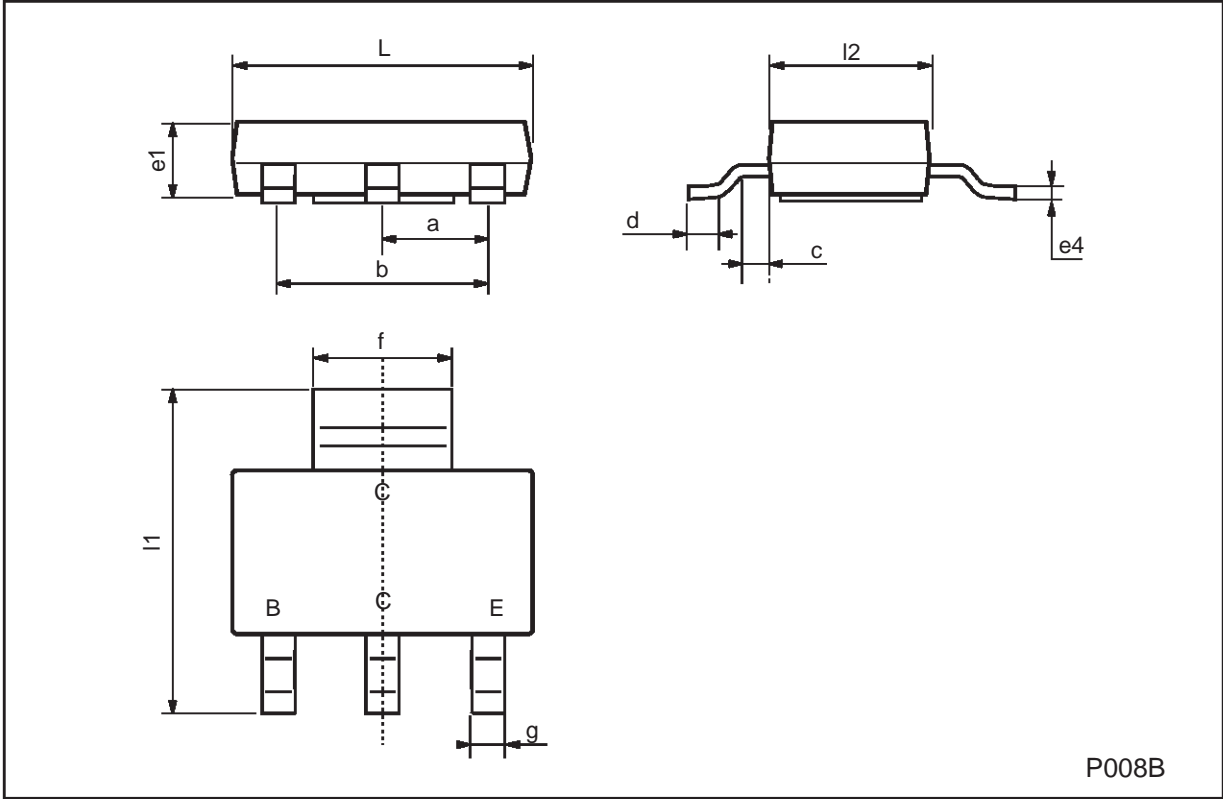
## TO-220 MECHANICAL DATA

DIM.	mm			inch		
	MIN.	TYP.	MAX.	MIN.	TYP.	MAX.
A	4.40		4.60	0.173		0.181
C	1.23		1.32	0.048		0.051
D	2.40		2.72	0.094		0.107
D1		1.27			0.050	
E	0.49		0.70	0.019		0.027
F	0.61		0.88	0.024		0.034
F1	1.14		1.70	0.044		0.067
F2	1.14		1.70	0.044		0.067
G	4.95		5.15	0.194		0.203
G1	2.4		2.7	0.094		0.106
H2	10.0		10.40	0.393		0.409
L2		16.4			0.645	
L4	13.0		14.0	0.511		0.551
L5	2.65		2.95	0.104		0.116
L6	15.25		15.75	0.600		0.620
L7	6.2		6.6	0.244		0.260
L9	3.5		3.93	0.137		0.154
DIA.	3.75		3.85	0.147		0.151



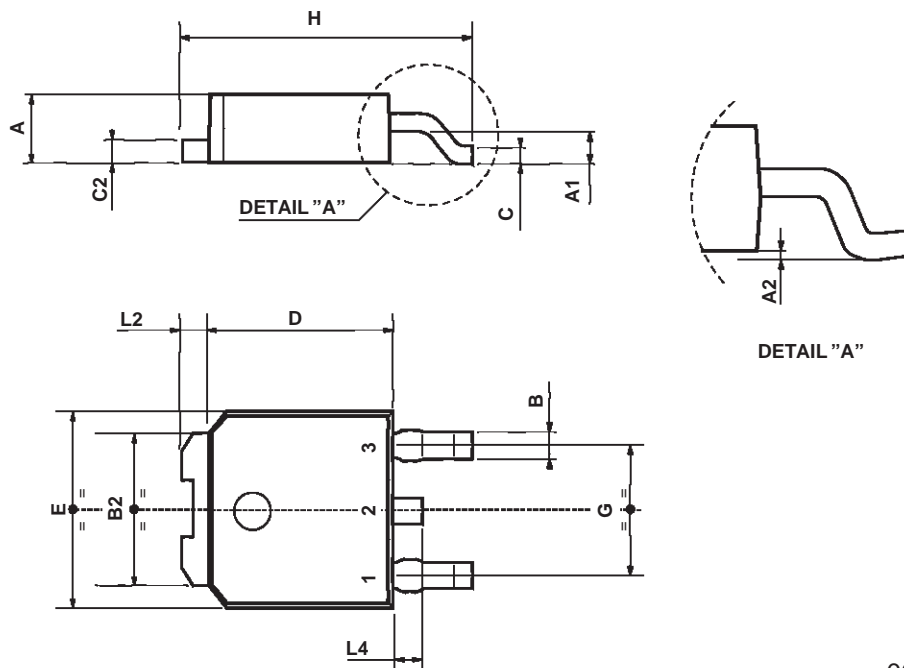
**SOT-223 MECHANICAL DATA**

DIM.	mm			mils		
	MIN.	TYP.	MAX.	MIN.	TYP.	MAX.
a	2.27	2.3	2.33	89.4	90.6	91.7
b	4.57	4.6	4.63	179.9	181.1	182.3
c	0.2	0.4	0.6	7.9	15.7	23.6
d	0.63	0.65	0.67	24.8	25.6	26.4
e1	1.5	1.6	1.7	59.1	63	66.9
e4			0.32			12.6
f	2.9	3	3.1	114.2	118.1	122.1
g	0.67	0.7	0.73	26.4	27.6	28.7
l1	6.7	7	7.3	263.8	275.6	287.4
l2	3.5	3.5	3.7	137.8	137.8	145.7
L	6.3	6.5	6.7	248	255.9	263.8



## TO-252 (DPAK) MECHANICAL DATA

DIM.	mm			inch		
	MIN.	TYP.	MAX.	MIN.	TYP.	MAX.
A	2.2		2.4	0.086		0.094
A1	0.9		1.1	0.035		0.043
A2	0.03		0.23	0.001		0.009
B	0.64		0.9	0.025		0.035
B2	5.2		5.4	0.204		0.212
C	0.45		0.6	0.017		0.023
C2	0.48		0.6	0.019		0.023
D	6		6.2	0.236		0.244
E	6.4		6.6	0.252		0.260
G	4.4		4.6	0.173		0.181
H	9.35		10.1	0.368		0.397
L2		0.8			0.031	
L4	0.6		1	0.023		0.039



0068772-B

Information furnished is believed to be accurate and reliable. However, STMicroelectronics assumes no responsibility for the consequences of use of such information nor for any infringement of patents or other rights of third parties which may result from its use. No license is granted by implication or otherwise under any patent or patent rights of STMicroelectronics. Specification mentioned in this publication are subject to change without notice. This publication supersedes and replaces all information previously supplied. STMicroelectronics products are not authorized for use as critical components in life support devices or systems without express written approval of STMicroelectronics.

The ST logo is a registered trademark of STMicroelectronics

© 2001 STMicroelectronics – Printed in Italy – All Rights Reserved

STMicroelectronics GROUP OF COMPANIES

Australia - Brazil - China - Finland - France - Germany - Hong Kong - India - Italy - Japan - Malaysia - Malta - Morocco  
Singapore - Spain - Sweden - Switzerland - United Kingdom - U.S.A.

<http://www.st.com>