

## VOICE COIL MOTOR DRIVER

- 5-12V OPERATION
- PARKING FUNCTION FOR HARD DISK HEAD ACTUATOR
- OUTPUT CURRENT UP TO 1A DC, 1.2A PEAK
- LOW SATURATION VOLTAGE
- LOGIC AND POWER SUPPLY MONITOR
- LINEAR CONTROL
- THERMAL PROTECTION
- ENABLE FUNCTION
- CURRENT SENSE RESISTOR CONNECTIONS

### DESCRIPTION

The L6243DS is a Bipolar IC developed for use in Mass Storage Head Actuator positioning applications. The Power Op-Amp Output Bridge, Differential Amplifier, and Error Amplifier, are controlled by TTL/CMOS, input compatible, Digital Logic, and an Analog Current Control Voltage. A simple RC compensation network, tied to the output of the Error Amp, will configure the system

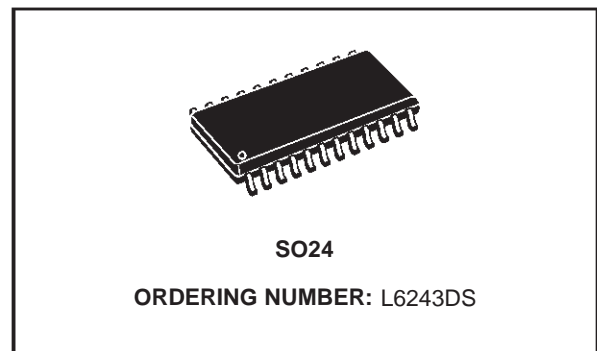

to work as a Transconductance Amplifier to drive a Voice Coil Motor in Linear Mode.

Additional features include Power On Reset Delay, Enable and Park. A logic low at the Park input activates the parking function. Holding the Enable input low will disable the device by forcing the outputs into a tristate mode. Power Fail Monitors for the logic and power supplies initiate an automatic parking sequence during a power failure. A resistor programmed parking voltage enables a constant velocity head retract.

### BLOCK DIAGRAM

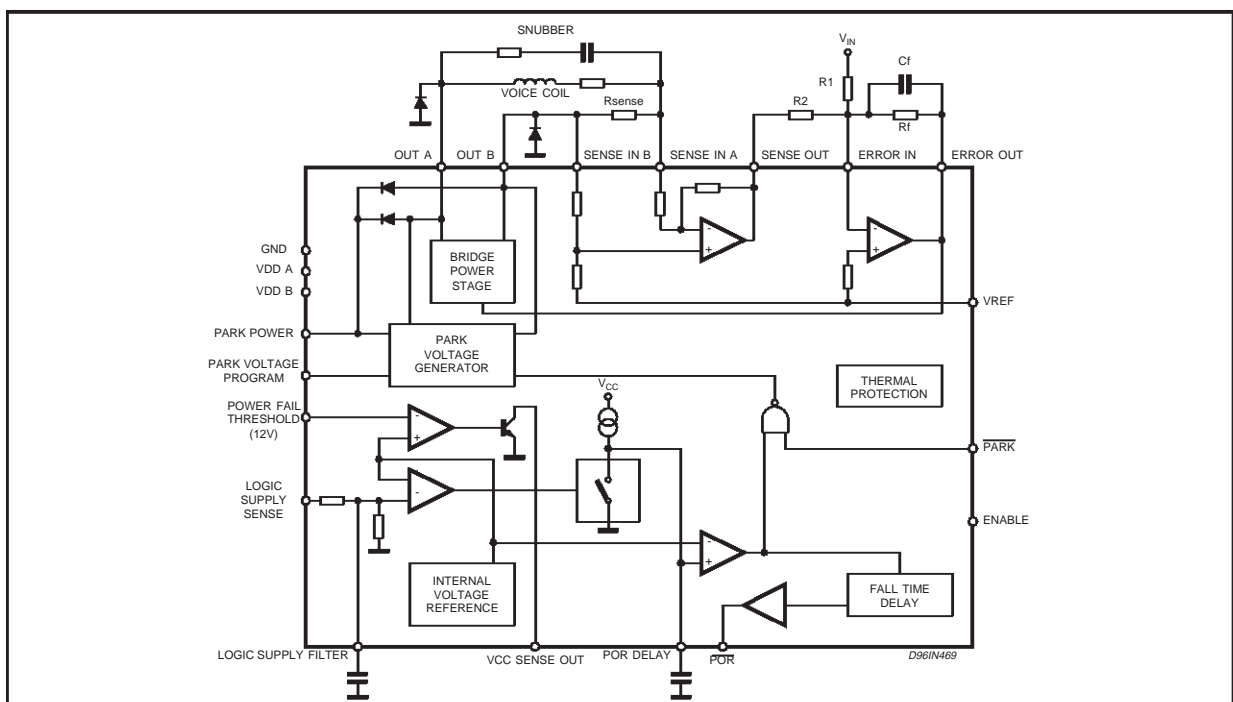

## L6243DS

### PIN CONNECTION (Top view)

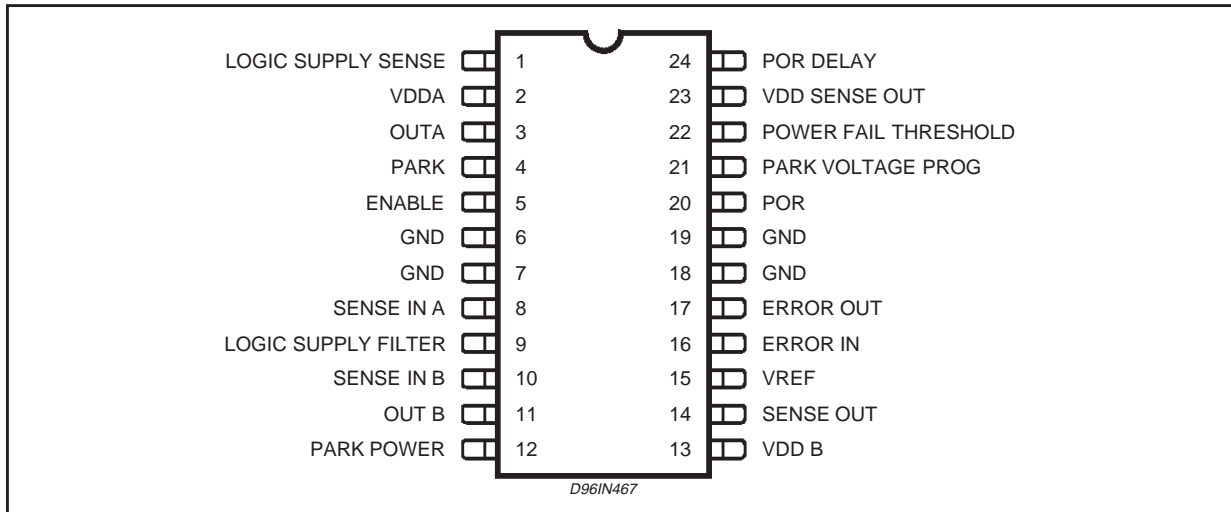

### ABSOLUTE MAXIMUM RATINGS

Symbol	Parameter	Value	Unit
$V_S$	Supply Voltage	14	V
$V_{IN}$	Input Voltage	0.3V to $V_S$	
$V_{ID}$	Differential Input Voltage	$\pm V_S$	
$I_O$	DC Output Current	1	A
$I_p$	Peak Output Current (non repetitive)	1.2	A
$P_{tot}$	Total Power Dissipation ( $T_{amb} = 70^\circ\text{C}$ )	1.2	W
$T_{stg}$	Storage and Junction Temperature	-55 to +150	$^\circ\text{C}$

### PIN FUNCTIONS

Name	Function
$V_{DD}$	Power supply.
GND	Common Ground.
$V_{ref}$	Voltage Reference.
ENABLE	Input. Logic low will disable IC.
PARK POWER	Input Power supply for the parking circuit.
CURRENT SENSE OUT	Current sense operational amplifier output.
ERROR AMP IN	Error amplifier inverting input.
ERROR AMP OUT	Error amplifier output.
SENSE IN A/B	Input for external sense resistors.
OUT A, B	Outputs of the two Power Operational Amplifiers Connections for Voice coil Motor.
PARK	External input for parking. Low will activate the park procedure.
PARK VOLTAGE PROGRAM	Input to set the park voltage.
POWER FAIL THRESHOLD	Supply monitor threshold setting.
LOGIC SUPPLY SENSE	Sense the logic supply level
POR	Power on reset output. Low will signal to the controller the failure of the logic supply.
POR DELAY	Capacitor connection to set the power on reset delay.
LOGIC SUPPLY FILTER	Capacitor connection to filter the logic supply ripple

## THERMAL DATA

Symbol	Description	Value	Unit
$R_{th\ j-amb}$	Thermal Resistance Junction - Ambient	77 to 97	°C/W

ELECTRICAL CHARACTERISTICS ( $V_S = 12V$ ,  $T_{amb} = 25^\circ C$ ; unless otherwise specified)

Symbol	Parameter	Test Condition	Min.	Typ.	Max.	Unit
$V_S$	Supply Range		4.5		13.2	V
$I_d$	Quiescent Drain Current			20		mA
$T_j$	Thermal Shutdown Junction Temperature			160		°C

## ERROR AMPLIFIER

$I_b$	Input Bias Current				1	$\mu A$
$I_{OS}$	Input Offset Current				300	nA
$V_{OS}$	Input Offset Voltage		-5		+5	mV
$G_v$	Large Signal Open Loop Voltage Gain		65			dB
GBW	Gain Bandwidth			3		MHz
$G_{min}$	Minimum Voltage Gain		5			
$I_{O+}$	Output Source Current			6		mA
$I_{O-}$	Output Sink Current			6		mA
SR	Slew-rate			2		V/ $\mu s$

## SENSE AMPLIFIER

$R_{IN}, V_{ref}$	$V_{ref}$ Input Impedance		9			K $\Omega$
$A_d$	Differential Gain			8		V/V
SR	Slew-rate			1		V/ $\mu s$
GBW	Gain Bandwidth Product			3		MHz
$R_{in}$	Sense Input Impedance		1.5			K $\Omega$
CMRR	Common Mode Rejection Ratio		55			dB

## POWER OP. AMP.

$G_v$	Voltage Gain			26		dB
$V_d$	Total Output Voltage Drop	$I_o = 250mA$ $I_o = 500mA$ $I_o = 1A$		450 750 1.15	1.5	mV mV V
$V_{off}$	Offset Voltage on Sense Resistor			5		mV
BW	Bandwidth on Resistive Load			100		KHz

**ELECTRICAL CHARACTERISTICS** (continued)  
**MONITORS AND CONTROL CIRCUIT**

Symbol	Parameter	Test Condition	Min.	Typ.	Max.	Unit
V <sub>t2</sub>	Threshold Voltage at Logic Supply Sense		4.2		4.5	V
V <sub>tL</sub>	Threshold Voltage at Power Fail Threshold Input		1.375	1.4	1.435	V
HV <sub>t2</sub>	Hysteresis on Vt2			50		mV
HV <sub>tL</sub>	Hysteresis on Vt2			15		mV
V <sub>ll</sub>	Low Level Voltage	Power on Reset = 2mA		250	500	mV
I <sub>e</sub>	Enable Input Current	V <sub>i</sub> = 2.4V			100	μA
		V <sub>i</sub> = 0.4V			-200	μA
I <sub>p</sub>	Input Current at Park	V <sub>i</sub> = 2.4V			100	μA
		V <sub>i</sub> = 0.4V			-200	μA
V <sub>enl</sub>	Enable Low Input Voltage				0.8	V
V <sub>enh</sub>	Enable High Input Voltage		2			V
V <sub>ph</sub>	Parking Input High Voltage		2			V
V <sub>pl</sub>	Parking Input Low Voltage				0.8	V
V <sub>pfl</sub>	Power Fail Low Output Voltage	I <sub>l</sub> = 2mA			0.5	V
I <sub>prog</sub>	Parking Voltage Program Current			100		μA
I <sub>ch</sub>	Power On Reset Delay Capacitor Charging			5		μA
R <sub>F</sub>	Equivalent Input Resistance at 5V Filter Input			6.9		kΩ

**FUNCTIONAL DESCRIPTION**

The VCM Driver is controlled via two control signals, ENABLE, POWER ON RESET. An analog input voltage, ERROR AMP IN, controls the polarity and amplitude of the VCM driving current.

Refer to figure two. This diagram is a representation of the function of the VCM System. Note that the signals with the bars represent the "not true", or "non asserted" condition. From initial power up, the system is held in the Park Mode. Upon completion of the POWER UP RESET DELAY the machine moves to Tristate Mode or Run Mode, depending upon the condition of the ENABLE input. If ENABLE is asserted, the machine moves directly to Run Mode. If ENABLE is not asserted, the machine moves to Tristate Mode.

POWER ON RESET is an asynchronous output. Additionally it affects the internal logic as a hard wired reset and therefore if a supply failure occurs during Tristate or Run state, the machine moves directly back to the Park Mode.

While in Tristate Mode, the assertion of ENABLE will move the machine to the Run Mode. Run Mode will typically be the steady running state. The deassertion of the ENABLE signal causes the machine to move into Tristate. If it is desired to perform an active Parking function, the PARK input must be driven low by the external hardware, or the the VCM can be driven to the Park position via the ERROR AMP IN control voltage

**BLOCK DESCRIPTION**
**OUTPUT STAGE**

It consists of two Power Op Amps connected in bridge configuration.

**CURRENT SENSE AMPLIFIER**

Differential amplifier whose inputs are connected to the sense lines and whose output is accessible externally. Closing the loop will transform the differential voltage signal from the sense lines into a current signal for the Error Amplifier.

**ERROR AMPLIFIER**

Error amplifier which drives the output stage. The input and the output pins are accessible externally.

**POWER SUPPLY MONITOR OPERATION**

The circuit monitors the logic supply voltage input (typ 5V) and activates Power on Reset output when such a supply drops below the safe operating limit. After the logic supply voltage reaches its nominal value a delay capacitor has to be charged [T<sub>delay</sub> = 3x2x10e5 x C sec] before Power on Reset output change from low to high level. Falling edges of Power on Reset are delayed (typ 4μs) in order to disable the writing on the disk before the Power on Reset is activated. An additional supervisor circuit is present in the

## FUNCTIONAL DESCRIPTION (continued)

Function	Description
V <sub>DD</sub> input	This is the Power Supply input.
POWER FAIL THRESH	Input for the V <sub>CC</sub> supply monitor. The Threshold can be externally set via a voltage divider.
V <sub>CC</sub> SENSE OUT Output	TTL compatible signal indicating the V <sub>CC</sub> supply has dropped below the POWER FAIL THRESHOLD.
LOGIC SUPPLY SENSE input	This pin allows the monitoring of 5V supply. When a low voltage is detected POR is asserted
PARK POWER input	This input is used during the Power Down/Power Fail Parking operation. When the supply goes down, a typical Spindle Driver Circuit automatically tristates its output stages. During this time the spindle motor spins freely and the stored energy is used to drive the VCM to the park position. The generated BEMF is rectified and filtered across an external PARKING CAPACITOR.
PROGRAMMABLE PARK VOLTAGE input	Used to set the voltage applied to the VCM during an Automatic Parking Operation.
PARK input	Logic signal asserted low, activates parking.
POWER ON RESET output	Indicates an error condition to the external control and support circuitry. A Logic Supply Fail condition automatically initiates a POWER ON RESET. Internal 30k Pullup to LSS.
POWER ON RESET DELAY input	The intent of this input is to provide a time delay at power up. During this time, the POWER ON RESET line will be asserted (low). A POWER ON RESET, will hold the system in the PARK mode. Once the delay has timed out, the POWER ON RESET will be removed to allow the external system to assume control. When applied in a Disk Drive Application, the POWER ON RESET DELAY will be required to have a minimum duration which will ensure that the Read/Write Heads can be fully parked.
ENABLE input	This signal originates at the external controller and, when asserted, allows the VCM Drivers to operate. When deasserted the VCM Driver is forced into Tristate mode. During a POWER ON RESET condition however, the parking operation is automatic and takes priority over the ENABLE function. Only at the end of the POWER ON RESET DELAY will the ENABLE input become active. If active parking is desired, it will be accomplished under control of the V <sub>IN</sub> signal, otherwise it is an automatic function at power down.
V <sub>REF</sub> input	The reference voltage input is basically that voltage, at which the output current is zero.
ERROR AMP IN input	Inverting input of error amplifier. The non inverting one is internally tied to V <sub>ref</sub> .
ERROR AMP OUT output	Error amplifier output pin. Open collector output.
OUTPUT A power output	Voice Coil power output.
OUTPUT B power output	Voice Coil power output.
SENSE AMP IN A/B signal input	Sense amplifier input pins. The sense resistor is connected across these pins.
SENSE AMP OUT signal output	Output pin of sense amplifier.
LOGIC SUPPLY FILTER	Capacitor connection to avoid false triggering

IC with a programmable threshold, which is set by an external resistive divider. The TTL compatible output can be used separately or connected to Park input in order to park the head.

voltage is set by connecting an external resistor between Park Voltage Program input and ground: ( $V_{park} = R_{ext} \times I_{ref}$ ,  $I_{ref} = 100\mu A$  typ). Connecting ENABLE input to GND the driver will be disabled (outputs in high impedance mode).

## PARKING CIRCUIT OPERATION

The voice coil driver is switched into the parking condition when Power on Reset output or Park input are low. In such a condition a fixed voltage is superimposed on the load and the value of such a

## THERMAL SHUTDOWN

It will disable the IC when the junction temperature exceeds the threshold value above which the device could be damaged.



Figure 1: Application Circuit

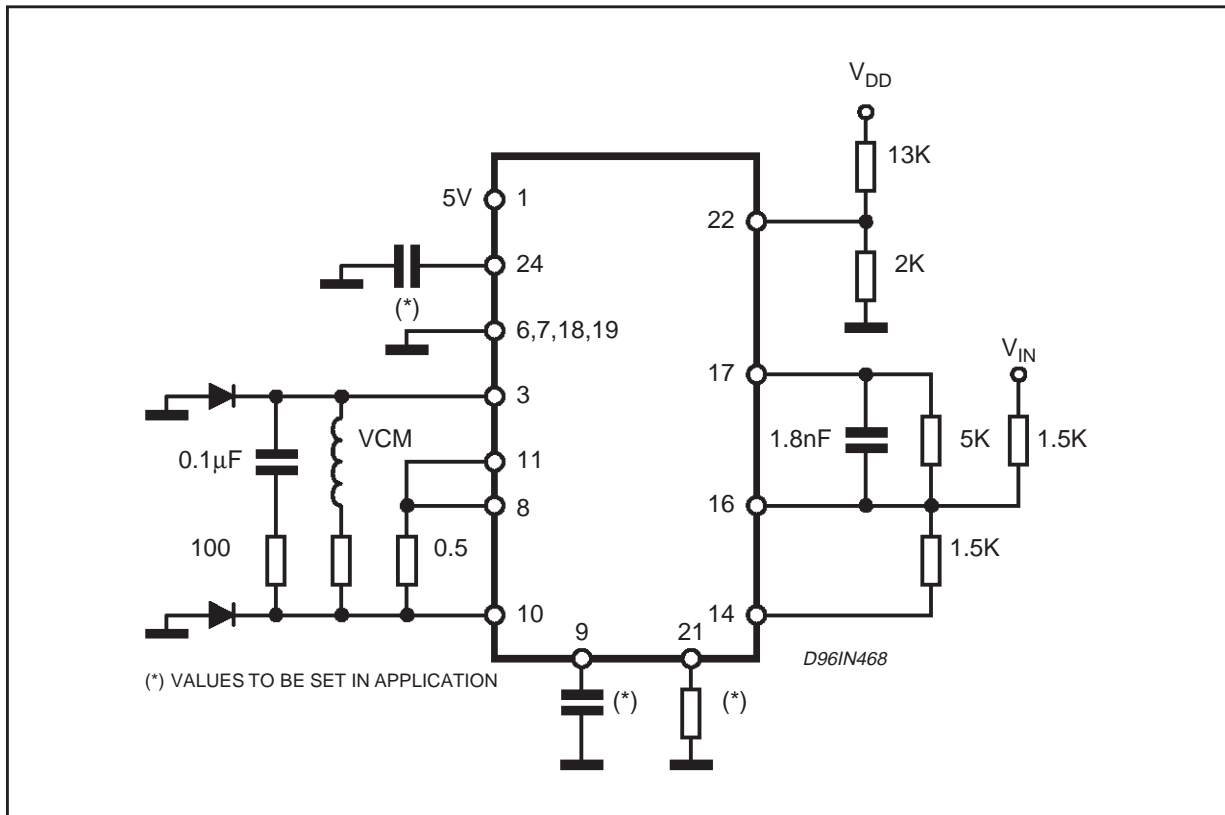
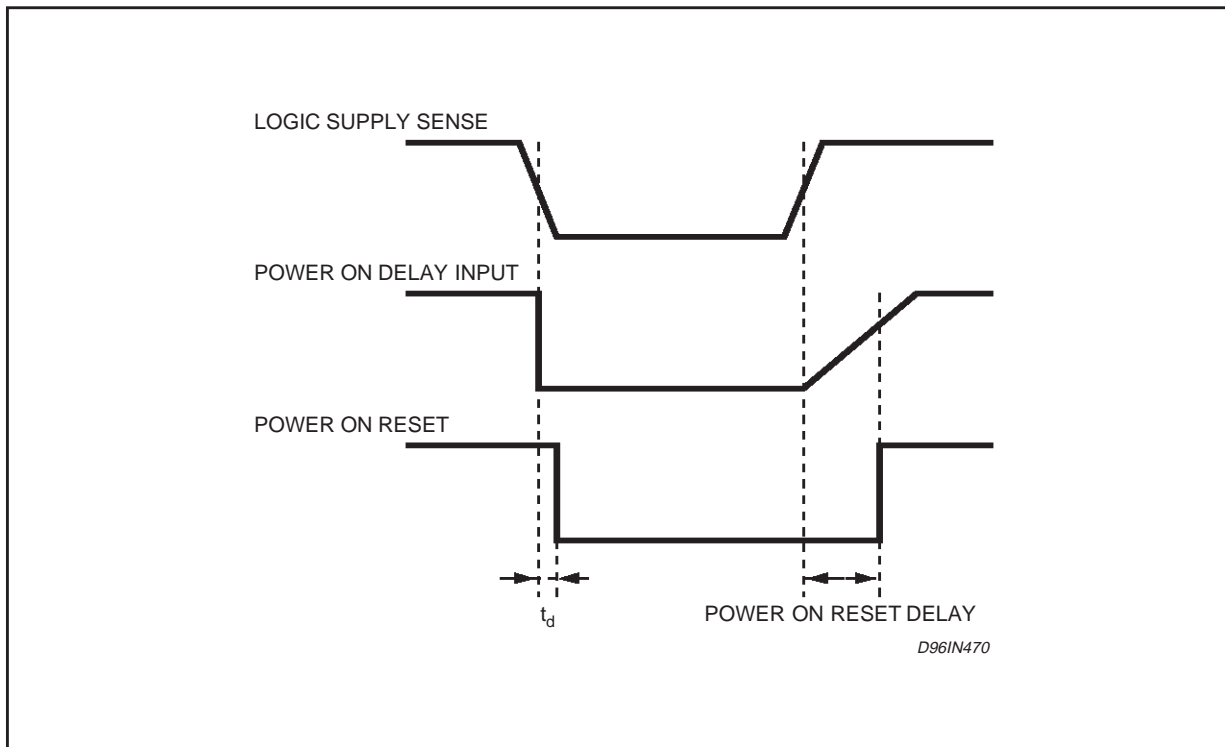
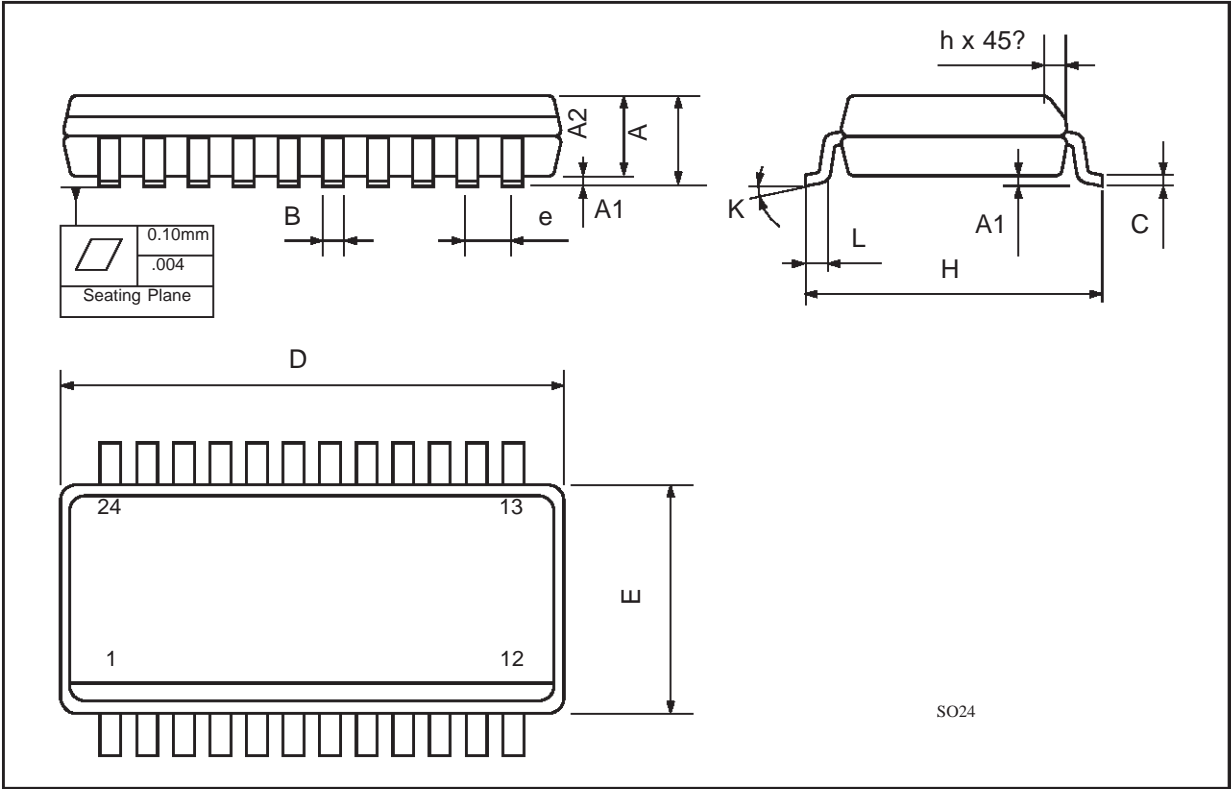

Figure 2: Application Circuit



SO24 PACKAGE MECHANICAL DATA

DIM.	mm			inch		
	MIN.	TYP.	MAX.	MIN.	TYP.	MAX.
A	2.35		2.65	0.093		0.104
A1	0.10		0.30	0.004		0.012
A2			2.55			0.100
B	0.33		0.51	0.013		0.0200
C	0.23		0.32	0.009		0.013
D	15.20		15.60	0.598		0.614
E	7.40		7.60	0.291		0.299
e		1.27			0,050	
H	10.0		10.65	0.394		0.419
h	0.25		0.75	0.010		0.030
k	0° (min.), 8° (max.)					
L	0.40		1.27	0.016		0.050



Information furnished is believed to be accurate and reliable. However, SGS-THOMSON Microelectronics assumes no responsibility for the consequences of use of such information nor for any infringement of patents or other rights of third parties which may result from its use. No license is granted by implication or otherwise under any patent or patent rights of SGS-THOMSON Microelectronics. Specification mentioned in this publication are subject to change without notice. This publication supersedes and replaces all information previously supplied. SGS-THOMSON Microelectronics products are not authorized for use as critical components in life support devices or systems without express written approval of SGS-THOMSON Microelectronics.

© 1998 SGS-THOMSON Microelectronics – Printed in Italy – All Rights Reserved

SGS-THOMSON Microelectronics GROUP OF COMPANIES

Australia - Brazil - Canada - China - France - Germany - Italy - Japan - Korea - Malaysia - Malta - Morocco - The Netherlands -  
Singapore - Spain - Sweden - Switzerland - Taiwan - Thailand - United Kingdom - U.S.A.