

DUAL INTELLIGENT POWER LOW SIDE SWITCH

- DUAL POWER LOW SIDE DRIVER WITH 2 x 5A
- LOW $R_{DS(ON)}$ TYPICALLY 200m Ω @ $T_J = 25^\circ\text{C}$
- INTERNAL OUTPUT CLAMPING DIODES $V_{FB}=50\text{V}$ FOR INDUCTIVE RECIRCULATION
- LIMITED OUTPUT VOLTAGE SLEW RATE FOR LOW EMI
- μP COMPATIBLE ENABLE AND INPUT
- WIDE OPERATING SUPPLY VOLTAGE RANGE 4.5V TO 45V
- REAL TIME DIAGNOSTIC FUNCTIONS:
 - OUTPUT SHORTED TO GND
 - OUTPUT SHORTED TO VSS
 - OPEN LOAD
 - LOAD BYPASS
- DEVICE PROTECTION FUNCTIONS:
 - OVERLOAD DISABLE
 - REVERSE BATTERY UP TO -16V @ V_S
 - THERMAL SHUTDOWN

MULTIPOWER BCD TECHNOLOGY

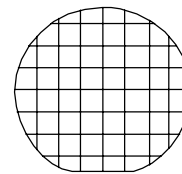

DIE

ORDERING NUMBER: L9377DIE1

BCD mixed technology. It is especially intended to drive valves in automotive environment. Its inputs are μP compatible for easy driving. Particular care has been taken to protect the device against failures, to avoid electro-magnetic interferences and to offer extensive real time diagnostic.

DESCRIPTION

The L9377 is a monolithic integrated dual low side driver realized in an advanced Multipower-

BLOCK DIAGRAM

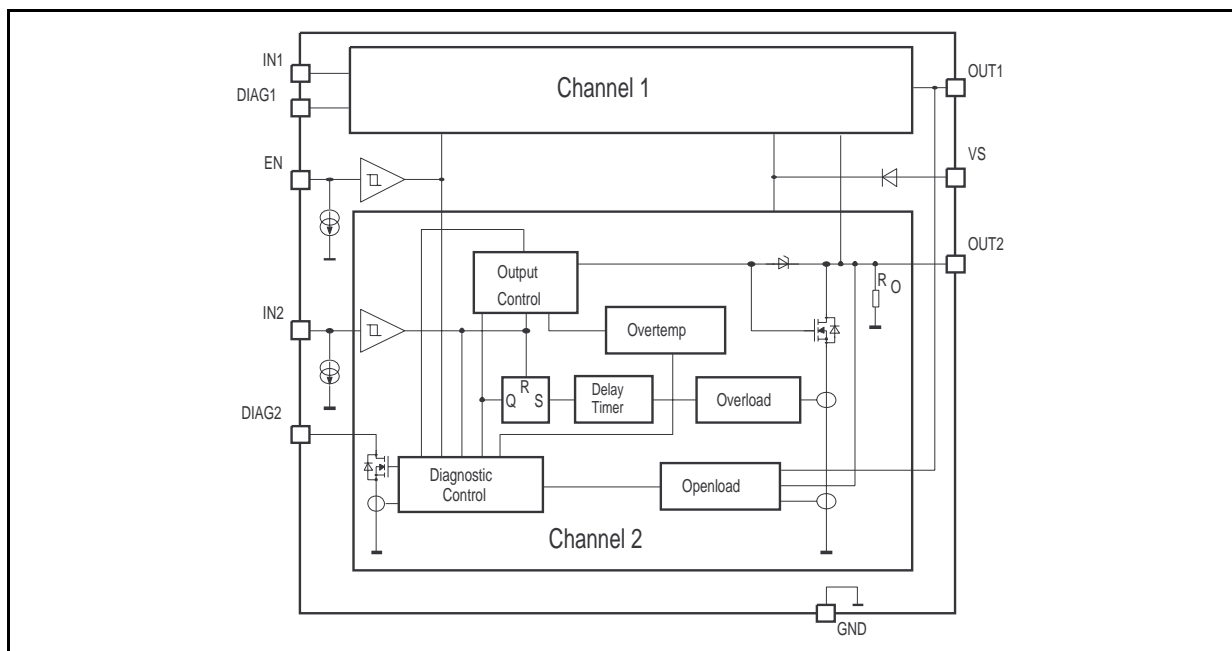

ABSOLUTE MAXIMUM RATINGS (no damage or latch)

Symbol	Parameter	Value	Unit
V _{SDC}	DC supply voltage	-16 to 45	V
V _{STR}	Transient supply voltage (t ≤ 500ms)	60	V
V _{IN,EN}	Input voltage (≤ 10mA)	-1.5 to 6	V
V _{DDC}	Diagnostic DC output voltage (≤ 50mA)	-0.3 to 16	V
V _{ODC}	DC output voltage	45	V
V _{OTR}	Transient output voltage (R _L ≥ 4Ω)	60	V
I _O	Output load current	internal limited	
I _{OR}	Reverse output current limited by load	-4	A
EO	Switch-off energy for inductive loads (t _{EO} = 250μs, T = 5ms)	50	mJ
T _{jEO}	Junction temperature during switch-off Σt ≤ 30min Σt ≤ 15min	175 190	°C °C
T _j	Junction temperature	-40 to +150	°C
T _a	Storage temperature	-55 to +150	°C
T _{jDIS}	Thermal disable junction temp, threshold	180 to 210	°C

ELECTRICAL CHARACTERISTICS (Operating Range) - The electrical characteristics are valid within the below defined operative range, unless otherwise specified.

Symbol	Parameter	Test Condition	Min.	Typ.	Max.	Unit
V _S	Board supply voltage		4.5	12	32	V
V _D	Stabilized diagnostic output voltage		-0.3	5	16	V
T _{j1}	Junction Temperature		-40		150	°C
T _{j2}	Junction temperature (Σt ≤ 15min *)		150		210	°C

*) Parameter will be guaranteed by correlation

Symbol	Parameter	Test Condition	Value T _{j1}			Value T _{j2}		Unit
			Min.	Typ.	Max.	Min.	Max.	
I _{SSB}	Static standby supply current	b)) c) V _{EN} = L, V _O ≥ V _{OUV}		0.73	1.5 15			mA mA
I _S	DC supply current	b)) c) V _{EN} = V _{IN} = H		1.3	5 15			mA mA
V _{DL}	Diagnostic output low voltage	b) I _D = 2mA c) I _D = 1mA		0.35	0.5		0.7	V
I _{DLE}	Diagnostic output leakage current	V _S = 0V or V _S = open; V _D = 5.5V T _j ≤ 125°C		0.1	2		20	μA
I _D	Diagnostic output current capability	V _D ≤ 16V DIAG = L	2	6	30			mA
V _{OUV}	Open load voltage threshold	V _{EN} = X, V _{IN} = L	0.51 x V _S	0.55 x V _S	0.59 x V _S	0.5 x V _S	0.65 x V _S	V
ΔV _{OUV1,2}	Open load difference voltage threshold	b) V _{EN} = X, V _{IN1,2} = L 16V ≥ V _{OC} ≥ V _{OUV} V _{OC} = output voltage of other channel c)	V _{OC} - 0.9V	V _{OC} - 1.25V	V _{OC} - 1.6V	0.8	1.7	V ¹⁾ V
I _{OUC}	Open load current threshold	a) V _{EN} = V _{IN} = H c)	100 20	320	480		580	mA mA

ELECTRICAL CHARACTERISTICS (continued)

Symbol	Parameter	Test Condition	Value T _{j1}			Value T _{j2}		Unit
			Min.	Typ.	Max.	Min.	Max.	
I _{OOC}	Over load current threshold	b)	5	7		4		A
V _{OCL}	Output voltage during clamping	I _{OCL} ≥ 100mA	45	52	60			V
S _{ON,OFF}	Output (fall, rise) slew rate	a) Fig. 2	200	1500	3200	200	3500	V/rms
R _{IO}	Internal output pull down resistor	V _{EN} = L	10	20	40		50	KΩ
R _{DS(on)}	Output on resistance	V _S > 9.5V I _O = 2A T _j = 25°C; T _j = 150°C		200	300 500			mΩ mΩ
V _{(EN,IN)L}	Logic input low voltage	I _{EN, IN} ≤ 10mA	-1.5		1		0.8	V
V _{(EN,IN)H}	Logic input high voltage		2		5.5			V
V _{(EN,IN)hys}	Logic input hysteresis		0.2	0.4	0.8			V
I _{EN}	Enable input sink current	1V ≤ V _{EN} ≤ 5.5V	10	30	60		80	μA
I _{IN}	Logic input sink current	1V ≤ V _{IN} ≤ 5.5V	40	95	180		240	μA
t _{D ON}	Output delay ON time	Fig. 2		4	25			μs
t _{D OFF}	Output delay OFF time		5	15	30			μs
t _{D H-L, Diag.}	Diag. delay output OFF time		5		65		90	μs
t _{D IOu}	Diagnostic open load delay time	Fig. 4		8	50			μs
t _{DOL}	Diagnostic overload delay switch-off time	Fig. 1	50	160	300			μs

a) 9V ≤ V_S ≤ 16V (Nominal operating range)

R_L ≤ 6Ω,

I_O ≤ I_{OOC}

b) 6.5V ≤ V_S ≤ 16V (Diagnostic operation range)

c) 4.5V ≤ V_S < 6.5V and 16V < V_S ≤ 32V (Extended operation range)

1) Limit under evaluation.

DIAGNOSTIC TABLE (Operating range: $4.5V \leq V_S \leq 32V$)

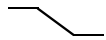
Conditions		EN	IN	Out	Diag.
Normal function		L	X	off	L
		H	L	off	L
		H	H	on (*)	H
GND short	$VO_{typ} < 0.55V$	L	X	off	H
Load bypass	$VO_{1,2} \geq 1.25V$	H	L	off	H
Open load	$IO_{typ} < 320mA$	H	H	on (*)	L
$T_j \text{ typ} \geq 175^\circ C$ Overtemperature (**)		X	L	off	H
		X	H	off	L
Latched Over load $IO_{min} > 5A$		X	H	off	L
Reset over load latch		X		D.C.	D.C.

(*) for $4.5V \leq V_S < 6.5V$, $IO \leq 2A$ diag. table is valid.

(**) If one diag. status shows the overtemp. recognition, in parallel this output will be switched OFF internally. The corresponding channel should be switched OFF additional by its Input or ENABLE signal, otherwise the overload latch will be set after t_{DOL} is passed. This behaviour will be related to the overdrop sensing which will be used as over load recognition.

Figure 1: Diagnostic overload delay time

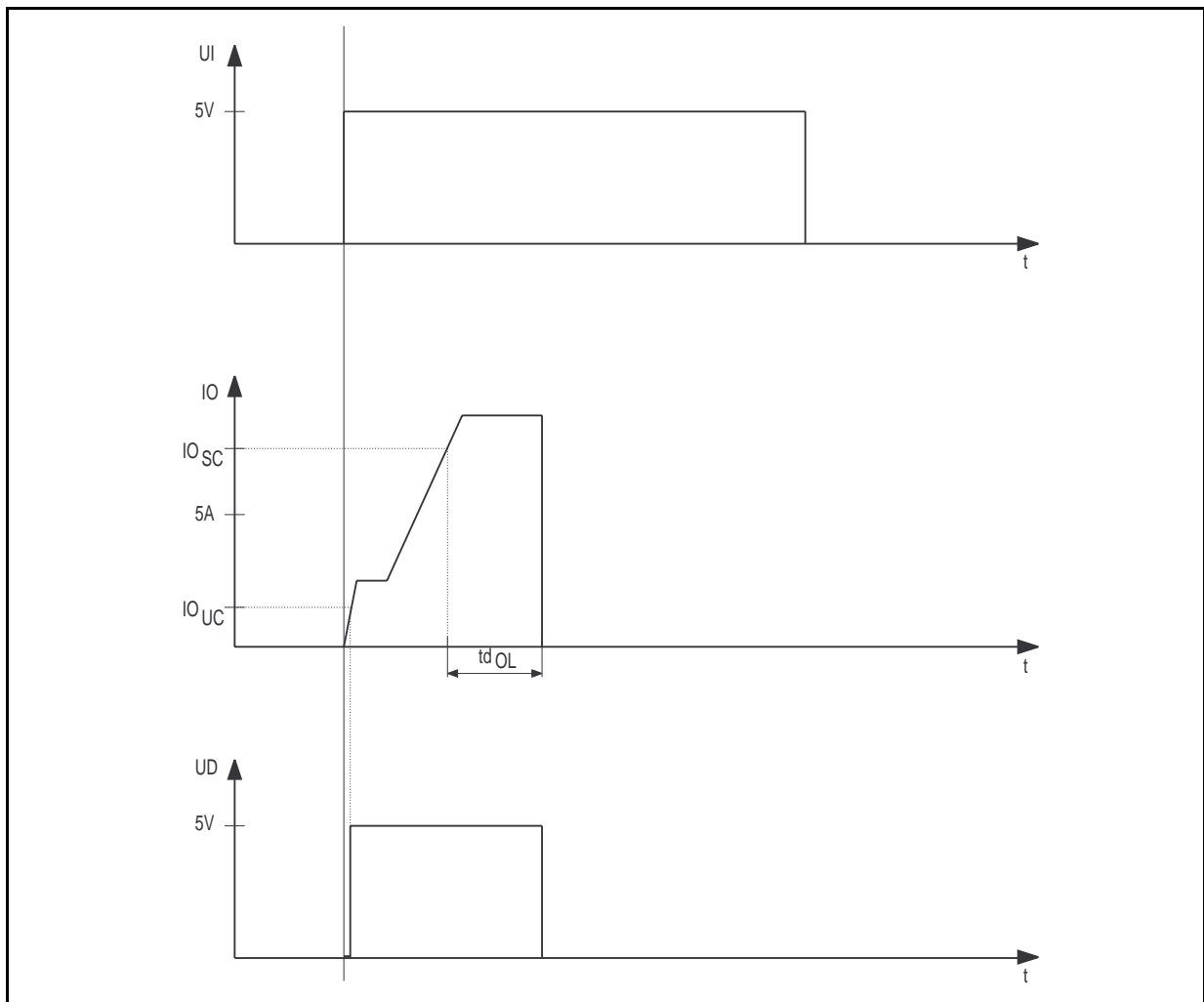

Figure 2: Output slope.

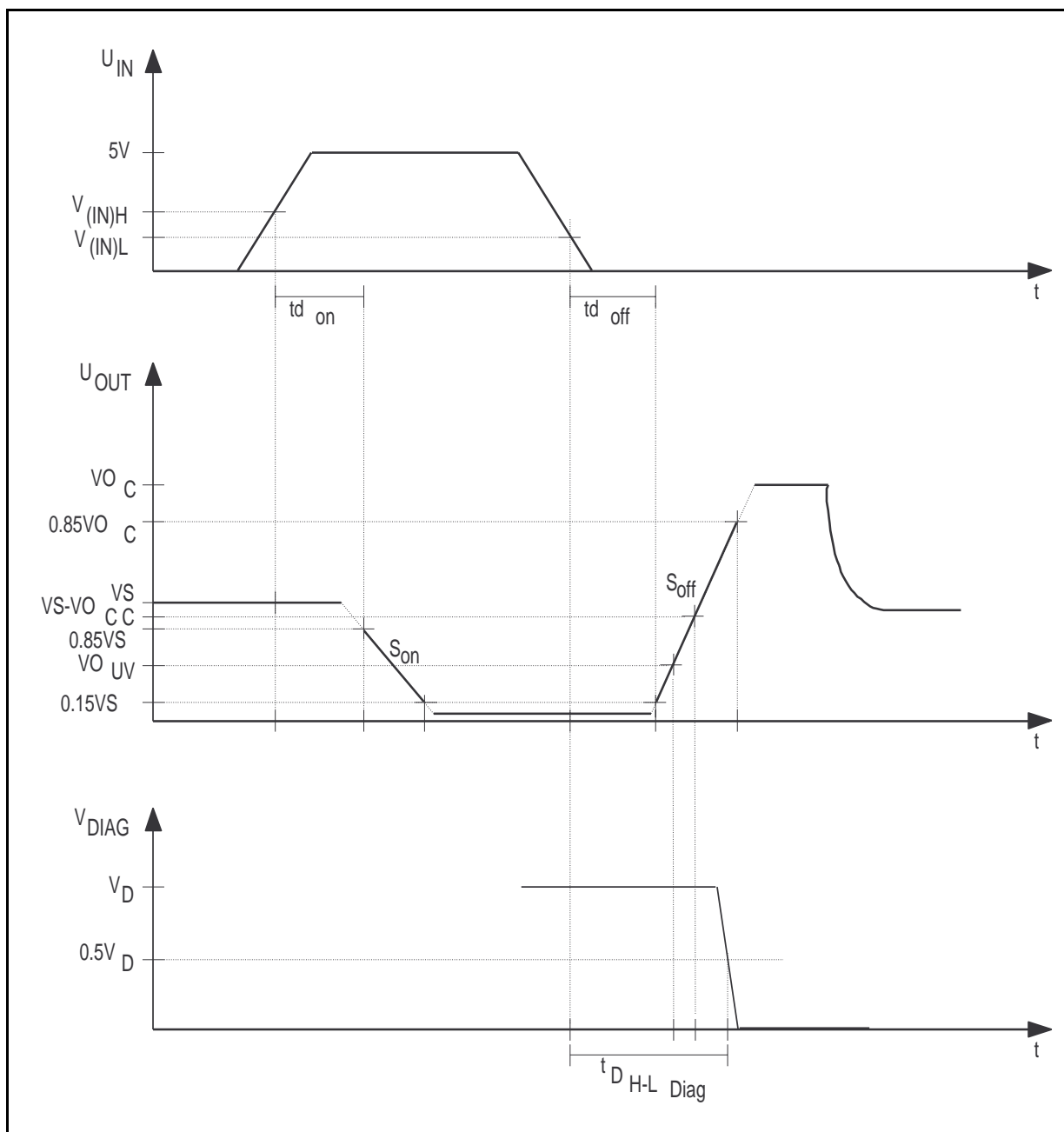

Figure 3: Block diagram - Open load voltage detection.

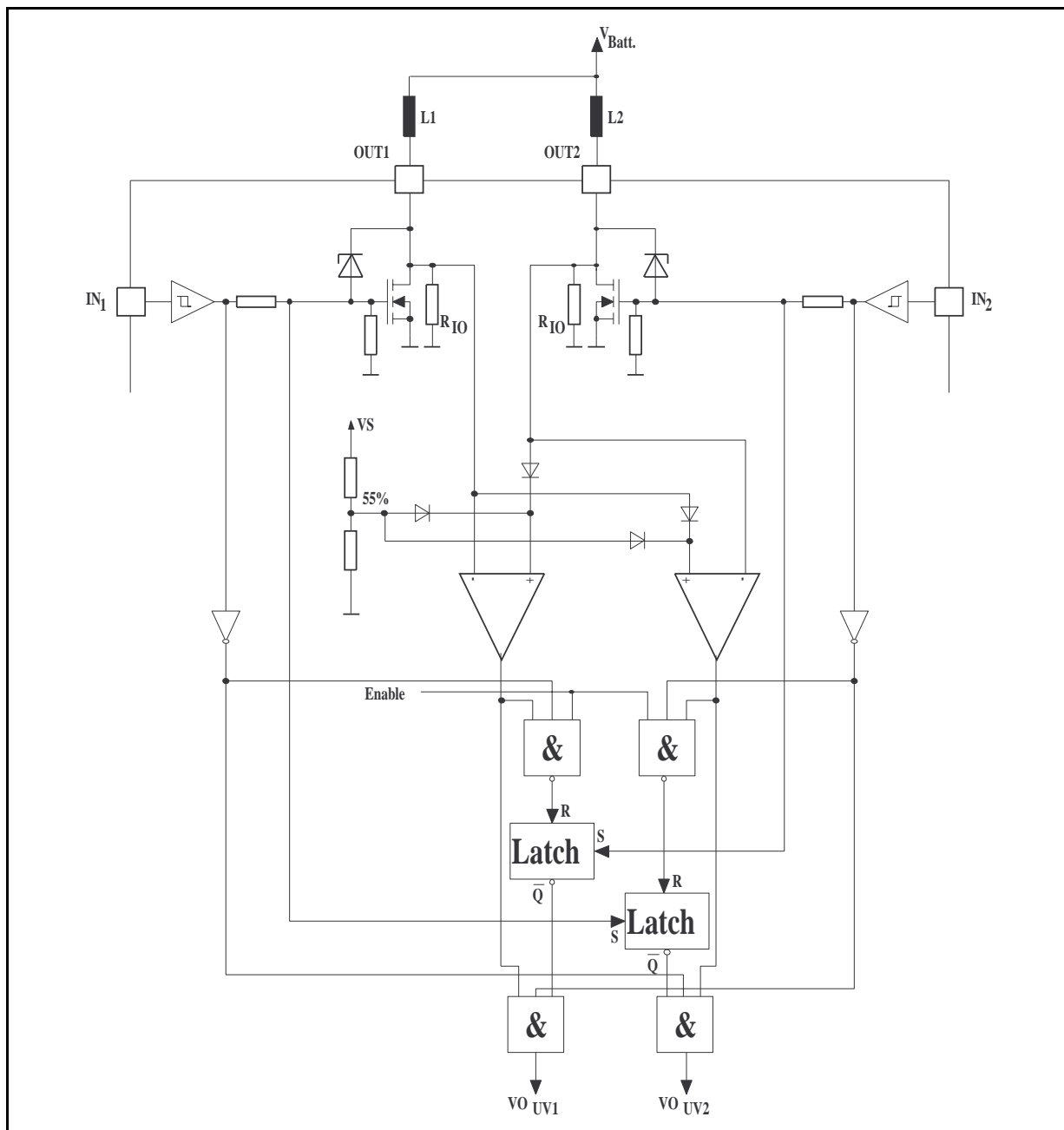
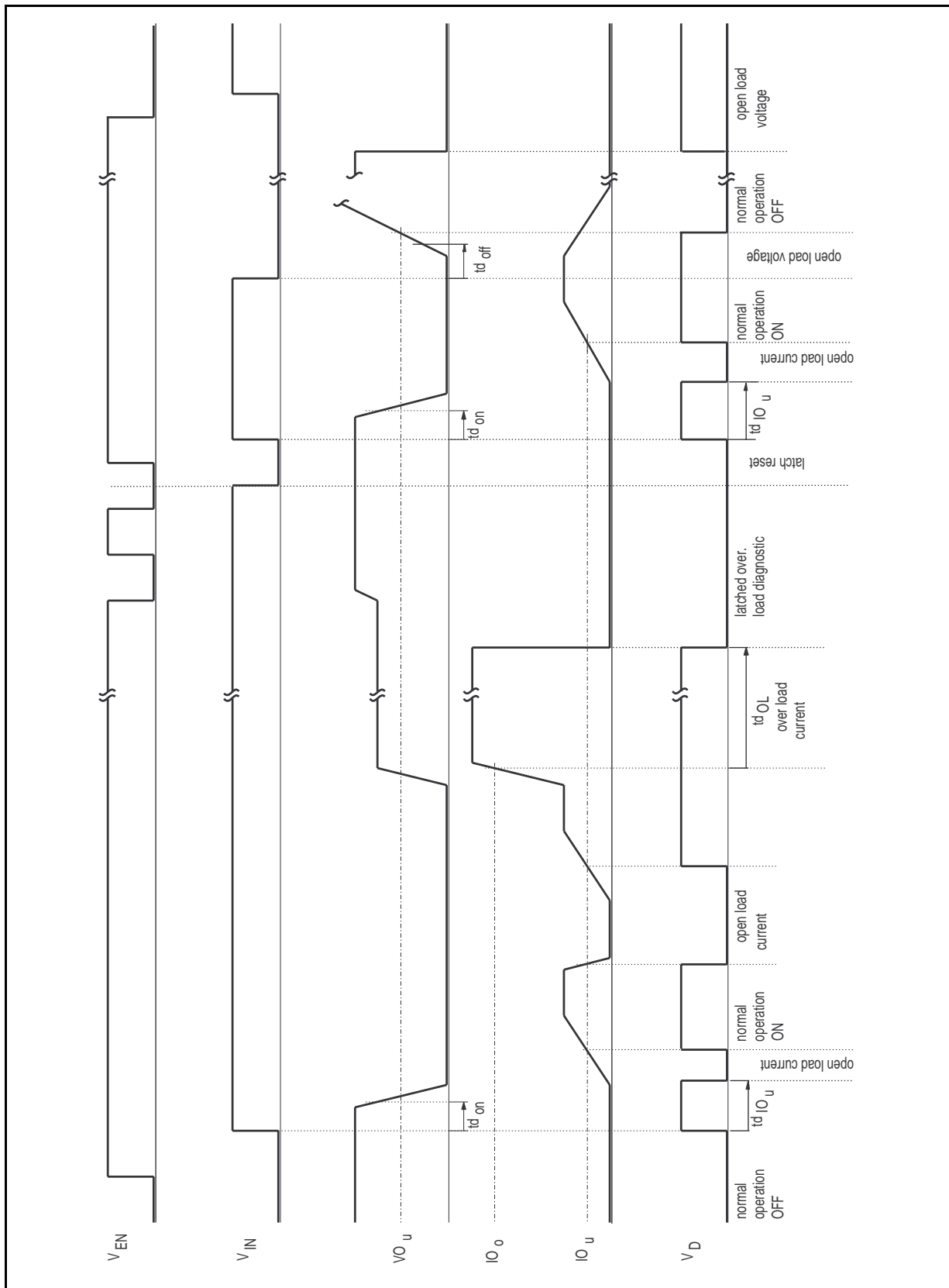

Figure 4: Logic diagram.



CIRCUIT DESCRIPTION

The L9377 is a dual low side driver for inductive loads like valves in automotive environment. The device is enabled by a common CMOS compatible ENABLE high signal. The internal pull down current sources at the ENABLE and INPUT pins protect the device in open input conditions against malfunctions. An output slope limitation for du/dt is implemented to reduce the EMI. An integrated active flyback voltage limitation clamps the output voltage during the flyback phase to 50V.

Each driver is protected against short circuit and thermal overload. In short circuit condition the output will be disabled after a short delay time t_{DOL} to suppress spikes. This disable is latched until a negative slope occurs at the correspondent input pin. The thermal disable for $T_J > 175^\circ\text{C}$ of the output will be reset if the junction temperature decreases about 20°C below the disable threshold temperature.

For the real time error diagnosis the voltage and the current of the outputs are compared with internal fixed values VO_{UV} for OFF and IO_{UC} for ON conditions to recognize open load ($R_L \geq 20\text{k}\Omega$, $R_L > 38\Omega$) in ON and OFF conditions. The diagnostic

operates also in the extended supply voltage range of $4.5\text{V} \leq VS \leq 32\text{V}$.

Also the output voltages $VO_{1,2}$ are compared each other in OFF condition with a fixed offset of $\Delta VO_{UV,1,2}$ to recognize GND bypasses. To suppress mail ΔVO diagnoses during the flyback phases of the compared output, the ΔVO diagnostic includes a latch function. Reaching the flyback clamping voltage VO_C the diagnostic signal is reset by a latch. To activate again this kind of diagnostic a low signal at the correspondent INPUT or the ENABLE pin must occur (see also Fig.3).

The diagnostic output level in connection with different ENABLE and INPUT conditions allows to recognize different fail states, like overtemp, short to VSS, short to GND, bypass to GND and disconnected load (see also page 7 diagnostic table).

The diagnostic output is also protected against short to UD_{max} . Overstepping the over load current threshold IO_o , the output current will be limited internally during the diagnostic overload delay switch-off time t_{DOL} .

Figure 5: Application circuit diagram.

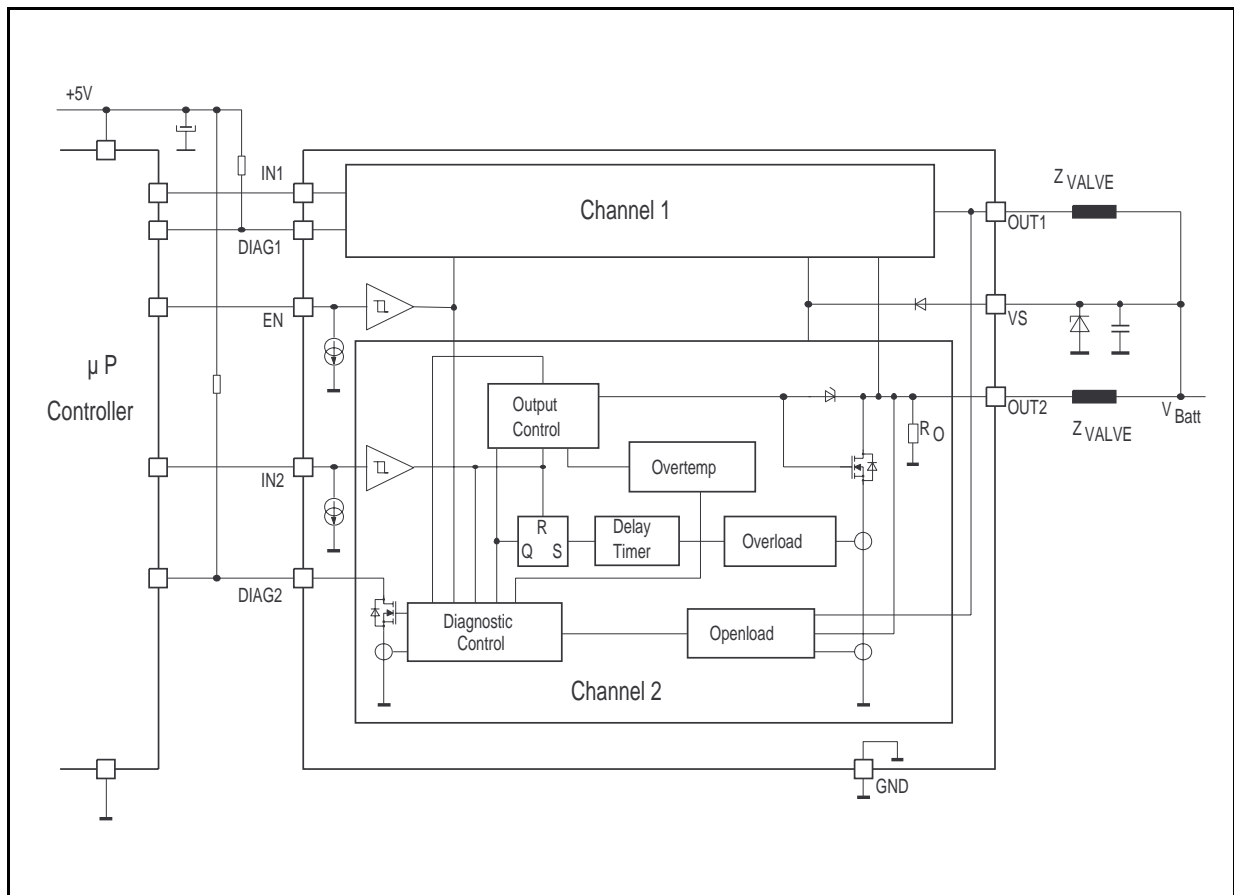

Information furnished is believed to be accurate and reliable. However, STMicroelectronics assumes no responsibility for the consequences of use of such information nor for any infringement of patents or other rights of third parties which may result from its use. No license is granted by implication or otherwise under any patent or patent rights of STMicroelectronics. Specification mentioned in this publication are subject to change without notice. This publication supersedes and replaces all information previously supplied. STMicroelectronics products are not authorized for use as critical components in life support devices or systems without express written approval of STMicroelectronics.

The ST logo is a registered trademark of STMicroelectronics

© 2000 STMicroelectronics – Printed in Italy – All Rights Reserved

STMicroelectronics GROUP OF COMPANIES

Australia - Brazil - China - Finland - France - Germany - Hong Kong - India - Italy - Japan - Malaysia - Malta - Morocco -
Singapore - Spain - Sweden - Switzerland - United Kingdom - U.S.A.

<http://www.st.com>