

Siemens Flatpanel-Display Technology

A&D IB SFT

TFT COLOR LCD MODULE

Type No. G23916-B65-H123

I-SFT 60.15XP

I-SFT Ô Rev. I

15“ 1024 x 768

SPECIFICATIONS

Internal Revision 0.1

26.11.2002

1	DESCRIPTION	4
2	FEATURES	4
3	APPLICATIONS	4
4	STRUCTURE AND FUNCTIONS	4
5	OUTLINE OF CHARACTERISTICS	5
6	BLOCK DIAGRAM	5
7	SPECIFICATIONS	6
7-1.	MECHANICAL INFORMATION	6
7-2.	ABSOLUTE MAXIMUM RATINGS OF ENVIRONMENT	6
7-3.	ELECTRICAL ABSOLUTE RATINGS	6
7-4.	ELECTRICAL CHARACTERISTICS	7
7-5.	INTERFACE PIN CONNECTION	8
7-6.	DISPLAY COLORS vs INPUT DATA SIGNAL	9
7-7.1	RELATIONSHIP BETWEEN INPUT DATA AND SCREEN IMAGE	10
7-7.2	TIMING DIAGRAMS OF INTERFACE SIGNAL	11
7-8.	TIMING PARAMETERS	12
7-9.	SUPPLY VOLTAGE SEQUENZE	13
7-10.	OPTICAL CHARACTERISTICS	14
7-11.	INVERTER SPECIFICATIONS	16
7-12.	OUTLINE DIMENSION	19
8	GENERAL PRECAUTIONS	20
8-1.	HANDLING	20
8-2.	STORAGE	20

SIEMENS

8-3.	<i>OPERATION</i>	21
------	------------------	----

8-4.	<i>OTHERS</i>	21
------	---------------	----

9	<i>COSMETIC SPECIFICATIONS</i>	22
----------	---------------------------------------	-----------

9-1.	<i>VISUAL INSPECTION</i>	22
------	--------------------------	----

9-2.	<i>DEFINITION OF ZONE</i>	23
------	---------------------------	----

9-3.	<i>COSMETIC SPECIFICATION</i>	24
------	-------------------------------	----

SIEMENS

1 DESCRIPTION

I-SFT 60.15XP (G23916-B65-H123) is a color active matrix TFT (Thin Film Transistor) liquid crystal display (LCD) that uses amorphous silicon TFT as switching devices. This model is composed of a TFT LCD panel, a driver circuit and a back-light system. The 15" display has a resolution of 1024 x 768 pixels and can display up to 16.777.216 colors. 6 o'clock direction is the optimum viewing angle.

2 FEATURES

- High brightness 800 cd/m²
- Extended temperature range
- High contrast ratio, high aperture structure
- XGA (1024x768 pixels) resolution
- Mercury free backlight system
- TTL Interface with 2pixels / clock

3 APPLICATIONS

- Point of Information / Point of Sales
- Monitors for industrial use

4 STRUCTURE AND FUNCTIONS

A TFT color LCD module comprises a TFT LCD panel and LSIs for driving the liquid crystal. The TFT LCD panel is composed of a TFT array glass substrate superimposed on a color filter glass substrate with liquid crystal filled in the narrow gap between two substrates.

RGB (Red, Green, Blue) data signals are sent through a signal processor to the LCD panel drivers after modulation into suitable forms for active matrix addressing.

Each of the liquid crystal cells acts as an electro-optical switch that controls the incident light transmission. The liquid crystal cell is driven by a signal applied to the TFT switch.

5 OUTLINE OF CHARACTERISTICS

ITEM	SPECIFICATION	UNIT	NOTE
Display area	304.128(H) x 228.096(V) (15 inch diagonal)	mm	
Driver element	a-Si TFT active matrix		
Display colors	16.777.216		
Number of pixels	1024 x 768	pixel	
Luminance (typ.)	800	cd/m ²	
Dimming range	100 to 20%		
Pixel arrangement	RGB vertical stripe		
Pixel pitch	0.297(H) x 0.297(W)	mm	
Display Mode	Normally White		
Surface treatment	Anti - glare, hard - Coating (3H)		

6 BLOCK DIAGRAM

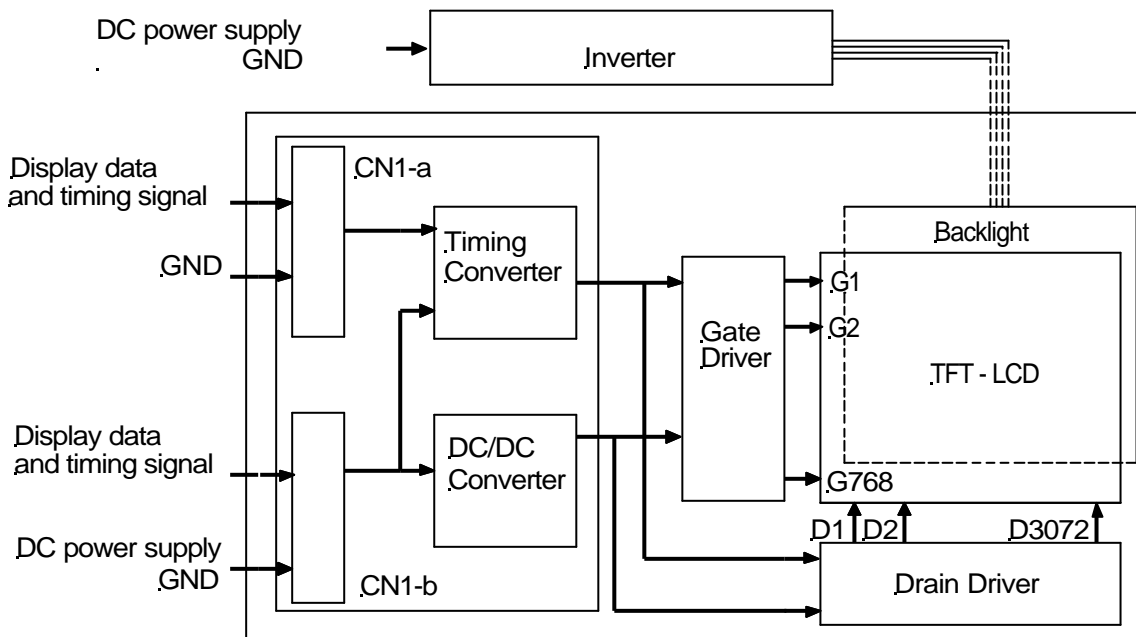

7 SPECIFICATIONS

7.1 MECHANICAL INFORMATION

ITEM		TYP.	UNIT
Module size	Horizontal (H)	353.7	mm
	Vertical (V)	264.0	mm
	Depth (D)	30.0	mm
Weight		3250	g

7.2 ABSOLUTE MAXIMUM RATINGS OF ENVIRONMENT

ITEM	SYMBOL	MIN.	MAX.	UNIT	NOTE
Storage temperature	T _{STG}	-25	70	°C	(1)
Operating temperature (Surface of Glass)	T _{OPR}	-10	60	°C	(1)
Shock (operating)	S _{hop}	-	35	g	(2)
Vibration (operating)	V _{hop}	-	3	g	(3)

Note

- (1) 70 % RH Max. No condensation.
- (2) 6 ms.
- (3) 10 - 2000 Hz.

7.3 ELECTRICAL ABSOLUTE RATINGS

TFT LCD MODULE

V_{SS} = 0 V

ITEM	SYMBOL	MIN.	MAX.	UNIT	NOTE
Power Supply Voltage for logic	VDD	0	6	V	
Input signal Voltage for logic	VI	-0.3	3.3 +0.3	V	(1)
Electrostatic Durability	VESDO	± 100		V	(2), (3)
	VESD1	± 8		KV	(2), (4)

Notes

- 1) The specification shall be applied to pixel data signal and clock signal.
- 2) Discharge circuit to be connected: 200 pF - 250 Ω, Environmental: 25°C - 70% RH
- 3) The specification shall be applied to I/F connector pins
- 4) The specification shall be applied to the surface of both a metal bezel and a LCD panel.

7.4 ELECTRICAL CHARACTERISTICS

TFT LCD MODULE

Ta=25±2°C

ITEM	Symbol	Min.	Typ.	Max.	Unit	Note
Power Supply Voltage	V _{DD}	4.5	5	5.5	V	
Power Supply Current	I _{DD}	-	370	-	mA	(1)
VSYNC Frequency	fV	58	60	75	Hz	
HSYNC Frequency	fH	46.8	48.4	60.2	kHz	
DCLK Frequency	fCLK	31.4	32.5	40	MHz	
Input Signals	ViL	-	-	0.8	V	
	ViH	2.0	-	-	V	

Note

- 1) DC current at fVK=60 Hz, fCLK=32.5 MHz, VDDK=5.0 V, and all black screen

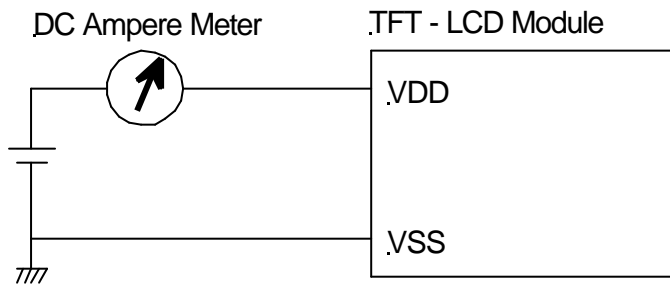

Inverter

Ta=25±2°C

ITEM	Symbol	Min.	Typ.	Max.	Unit	Note
Power Supply Voltage	V _{inv}	-	24	-	V	
Power Supply Current	I _{inv}	-	1.70	-	A	

7.5 INTERFACE PIN CONNECTION

TFT LCD MODULE (Interface Signal & Power)

Connector: Molex 53475, Matching Socket: Molex 52760

Pin No.	Symbol	Description	Note	Pin No.	Symbol	Description	Note
1	VSS	GND (0V)		41	VSS	GND (0V)	
2	PEV B0	Pixel Data	1)	42	POD G0	Pixel Data	1)
3	PEV B1	Pixel Data	1)	43	POD G1	Pixel Data	1)
4	PEV B2	Pixel Data		44	POD G2	Pixel Data	
5	PEV B3	Pixel Data		45	POD G3	Pixel Data	
6	VSS	GND (0V)		46	VSS	GND (0V)	
7	PEV B4	Pixel Data		47	POD G4	Pixel Data	
8	PEV B5	Pixel Data		48	POD G5	Pixel Data	
9	PEV B6	Pixel Data		49	POD G6	Pixel Data	
10	PEV B7	Pixel Data		50	POD G7	Pixel Data	
11	VSS	GND (0V)		51	VSS	GND (0V)	
12	PEV G0	Pixel Data	1)	52	POD R0	Pixel Data	1)
13	PEV G1	Pixel Data	1)	53	POD R1	Pixel Data	1)
14	PEV G2	Pixel Data		54	POD R2	Pixel Data	
15	PEV G3	Pixel Data		55	POD R3	Pixel Data	
16	VSS	GND (0V)		56	VSS	GND (0V)	
17	PEV G4	Pixel Data		57	POD R4	Pixel Data	
18	PEV G5	Pixel Data		58	POD R5	Pixel Data	
19	PEV G6	Pixel Data		59	POD R6	Pixel Data	
20	PEV G7	Pixel Data		60	POD R7	Pixel Data	
21	VSS	GND (0V)		61	VSS	GND (0V)	
22	PEV R0	Pixel Data	1)	62	VSS	GND (0V)	
23	PEV R1	Pixel Data	1)	63	PDCLK	Pixel Dot Clock	
24	PEV R2	Pixel Data		64	VSS	GND (0V)	
25	PEV R3	Pixel Data		65	VSS	GND (0V)	
26	VSS	GND (0V)		66	PDHS	H - Sync	
27	PEV R4	Pixel Data		67	VSS	GND (0V)	
28	PEV R5	Pixel Data		68	VSS	GND (0V)	
29	PEV R6	Pixel Data		69	PDEN	DTMG	
30	PEV R7	Pixel Data		70	PDVS	V- Sync	
31	VSS	GND (0V)		71	VDD	Power Supply typ.+5V	
32	POD B0	Pixel Data	1)	72	VDD	Power Supply typ.+5V	
33	POD B1	Pixel Data	1)	73	VDD	Power Supply typ.+5V	
34	POD B2	Pixel Data		74	VDD	Power Supply typ.+5V	
35	POD B3	Pixel Data		75	VDD	Power Supply typ.+5V	
36	VSS	GND (0V)		76	VSS	GND (0V)	
37	POD B4	Pixel Data		77	P ID2	NC	
38	POD B5	Pixel Data		78	P ID1	NC	
39	POD B6	Pixel Data		79	FRC_CTL	8bit:+3.3V,6bit:GND	
40	POD B7	Pixel Data		80	VSS	GND (0V)	

Note

1)6-bit Mode shall be connected to VSS.

7.6 DISPLAY COLOR vs INPUT DATA SIGNAL

Color	Input	Red Data								Green Data								Blue Data							
		R7	R6	R5	R4	R3	R2	R1	R0	G7	G6	G5	G4	G3	G2	G1	G0	B7	B6	B5	B4	B3	B2	B1	B0
		MSB				LSB				MSB				LSB				MSB				LSB			
Basic Color	Black	0	0	0	0	0	0	0	0	0	0	0	0	0	0	0	0	0	0	0	0	0	0	0	0
	Red (255)	1	1	1	1	1	1	1	1	0	0	0	0	0	0	0	0	0	0	0	0	0	0	0	0
	Green (255)	0	0	0	0	0	0	0	0	1	1	1	1	1	1	1	1	0	0	0	0	0	0	0	0
	Blue (255)	0	0	0	0	0	0	0	0	0	0	0	0	0	0	0	0	1	1	1	1	1	1	1	1
	Cyan	0	0	0	0	0	0	0	0	1	1	1	1	1	1	1	1	1	1	1	1	1	1	1	1
	Magenta	1	1	1	1	1	1	1	1	0	0	0	0	0	0	0	0	1	1	1	1	1	1	1	1
	Yellow	1	1	1	1	1	1	1	1	1	1	1	1	1	1	1	1	0	0	0	0	0	0	0	0
	White	1	1	1	1	1	1	1	1	1	1	1	1	1	1	1	1	1	1	1	1	1	1	1	1
Red	Black	0	0	0	0	0	0	0	0	0	0	0	0	0	0	0	0	0	0	0	0	0	0	0	0
	Red (1)	0	0	0	0	0	0	0	1	0	0	0	0	0	0	0	0	0	0	0	0	0	0	0	0
	Red (2)	0	0	0	0	0	0	1	0	0	0	0	0	0	0	0	0	0	0	0	0	0	0	0	0
	:	:	:	:	:	:	:	:	:	:	:	:	:	:	:	:	:	:	:	:	:	:	:	:	:
	:	:	:	:	:	:	:	:	:	:	:	:	:	:	:	:	:	:	:	:	:	:	:	:	:
	Red (254)	1	1	1	1	1	1	1	0	0	0	0	0	0	0	0	0	0	0	0	0	0	0	0	0
	Red (255)	1	1	1	1	1	1	1	1	0	0	0	0	0	0	0	0	0	0	0	0	0	0	0	0
	Black	0	0	0	0	0	0	0	0	0	0	0	0	0	0	0	0	0	0	0	0	0	0	0	0
Green	Green (1)	0	0	0	0	0	0	0	0	0	0	0	0	0	0	0	1	0	0	0	0	0	0	0	0
	Green (2)	0	0	0	0	0	0	0	0	0	0	0	0	0	0	1	0	0	0	0	0	0	0	0	0
	:	:	:	:	:	:	:	:	:	:	:	:	:	:	:	:	:	:	:	:	:	:	:	:	
	:	:	:	:	:	:	:	:	:	:	:	:	:	:	:	:	:	:	:	:	:	:	:	:	
	Green (254)	0	0	0	0	0	0	0	0	1	1	1	1	1	1	1	0	0	0	0	0	0	0	0	0
	Green (255)	0	0	0	0	0	0	0	0	1	1	1	1	1	1	1	1	0	0	0	0	0	0	0	0
	Black	0	0	0	0	0	0	0	0	0	0	0	0	0	0	0	0	0	0	0	0	0	0	0	0
	Blue	Blue (1)	0	0	0	0	0	0	0	0	0	0	0	0	0	0	0	0	0	0	0	0	0	0	0
Blue (2)		0	0	0	0	0	0	0	0	0	0	0	0	0	0	0	0	0	0	0	0	0	0	1	0
:		:	:	:	:	:	:	:	:	:	:	:	:	:	:	:	:	:	:	:	:	:	:	:	
:		:	:	:	:	:	:	:	:	:	:	:	:	:	:	:	:	:	:	:	:	:	:	:	
Blue (254)		0	0	0	0	0	0	0	0	0	0	0	0	0	0	0	0	1	1	1	1	1	1	1	0
Blue (255)		0	0	0	0	0	0	0	0	0	0	0	0	0	0	0	0	1	1	1	1	1	1	1	1

Notes 1) Definition of gray scale:

Color(n) Number in paranthesis indicates gray scale level. Larger n corresponds to brighter level.

2) Data: 1: High, 0: Low

7.7.1 RELATIONSHIP BETWEEN INPUT DATA AND SCREEN IMAGE

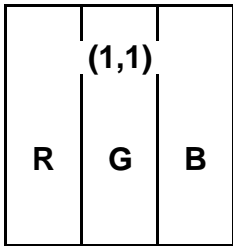

Pixel: PEVR0~R7 : R data
 PODR0~R7 : R data
 PEVG0~G7 : G data
 PODG0~G7 : G data
 PEVB0~B7 : B data
 POVB0~B7 : B data

1,1	1,2	1,3	_____	1,1024
2,1	2,2	2,3	_____	2,1024
3,1	3,2	3,3	_____	3,1024
768,1	768,2	768,3	_____	768,1024

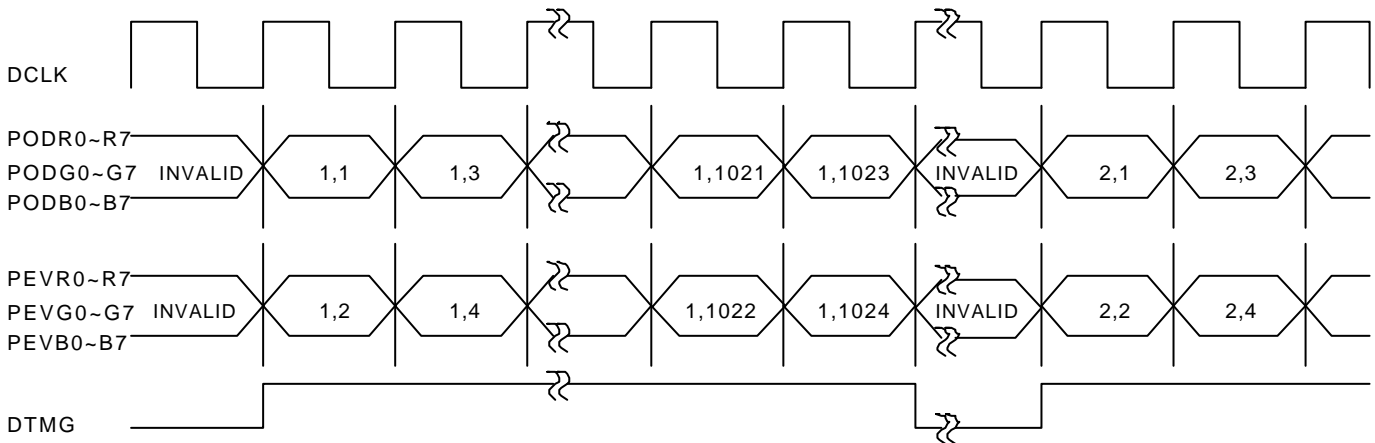

7.7.2 TIMING DIAGRAMS OF INTERFACE SIGNAL

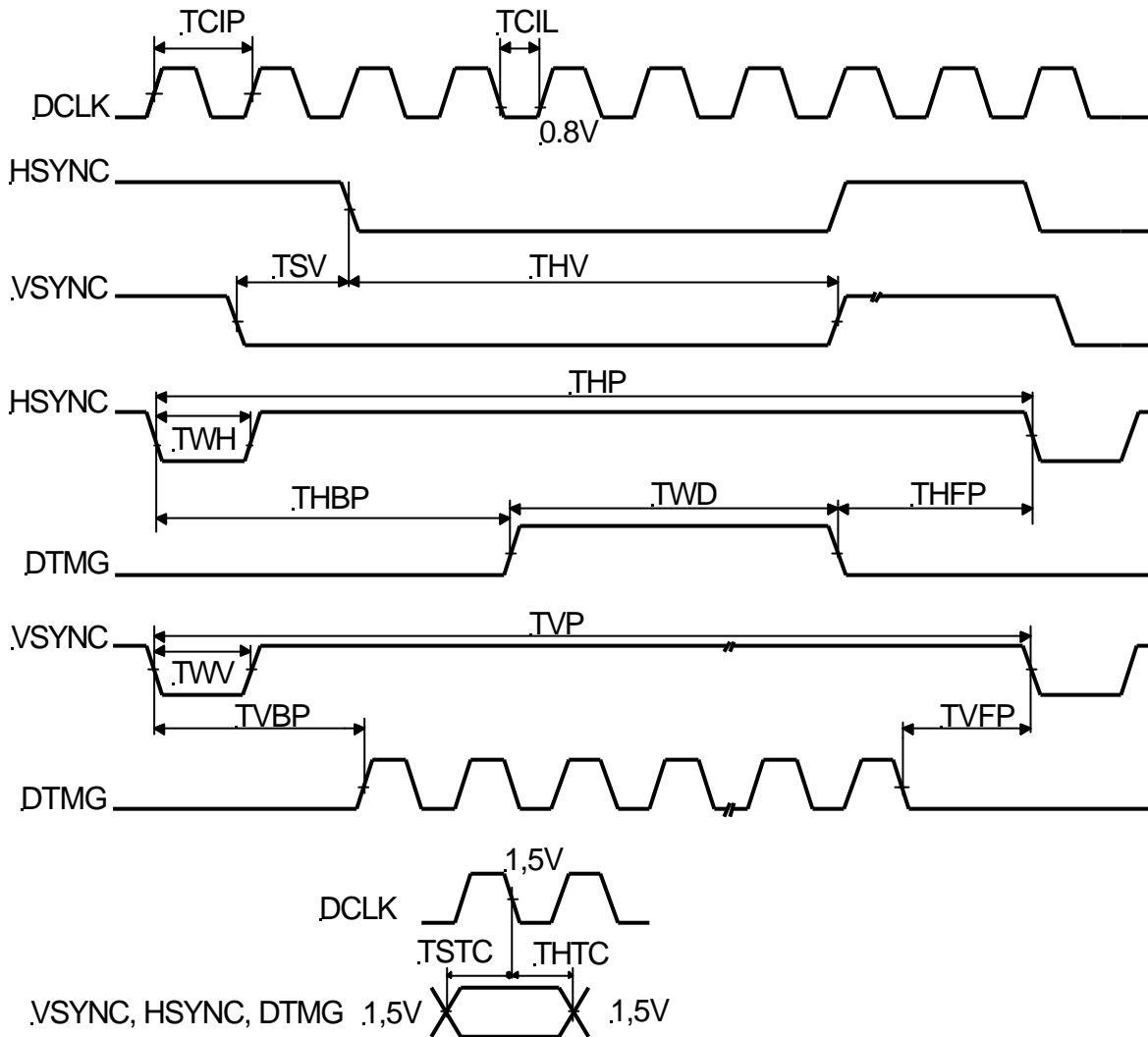

PEVRO ~ R7, PEVG ~ G7, PEVB0 ~ B7, PEVR0 ~ R7, PODG0 ~ G7, PODB0 ~ B7

Notes

- 1) Reference level for each timing signal is 1.5V unless it is stated on the chart, high level voltage (VIH) and low level voltage (VIL) are defined as follows:

$$V_{IH} \geq 2.0 \text{ V} \quad V_{IL} \leq 0.8 \text{ V}$$
- 2) HSYNC, VSYNC timing is specified in negative polarity.
- 3) HSYNC pulse is need while data is invalid (blanking period)

7.8 TIMING PARAMETERS

Item		Symbol	MIN	TYP	MAX	Unit	Note
DCLK	Period	TCIP	25	-	40	Ns	
	Duty	D	0.35	0.5	0.65		D=TCIL/TCIP
HSYSNC	Period	THP	535	-	1022	TCIP	5)
	Width - Active	TWH	8	-	120	TCIP	
VSYNC	Set up Time	TSV	0	-	-	TCIP	To HSYNC
	Hold Time	THV	2	-	-	TCIP	
	Period	TVP	771	-	1000	THP	
	Width - Active	TWV	1	-	120	THP	
DTMG	Horizontal Back Porch	THBP	28	-	510	TCIP	5), 6)
	Horizontal Front Porch	THFP	0	-	1)	TCIP	
	Vertical Back Porch	TVBP	3	-	2)	THP	
	Vertical Front Porch	TVFP	0	-	2)	THP	
	Width - Active	TWD	512	-	-	TCIP	
COMMOM	Set up Time	TSTC	6	-	-	ns	
	Hold Time	THTC	2	-	-	ns	

Note

- 1) $THBP + THFP \leq 260 \text{ TCIP}$
- 2) $TVBP + TVFP \leq 232 \text{ THP}$
- 3) $fV = 1/TVP \leq 75 \text{ HZ}$
- 4) $fH = 1/THP \leq 60.24 \text{ kHz}$
- 5) When $THP = 1024$ is coming, Display does not work.
In this case, the following procedure is recommended.

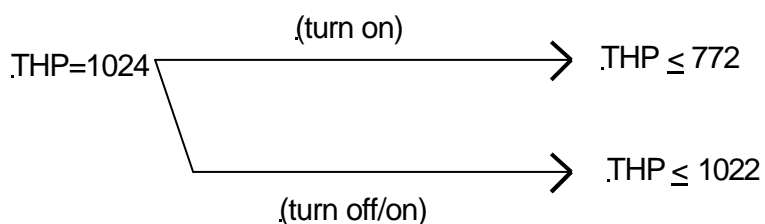

- 6) 16 of 28 is used data transfer a new FCA system.

7.9 SUPPLY VOLTAGE SEQUENCE

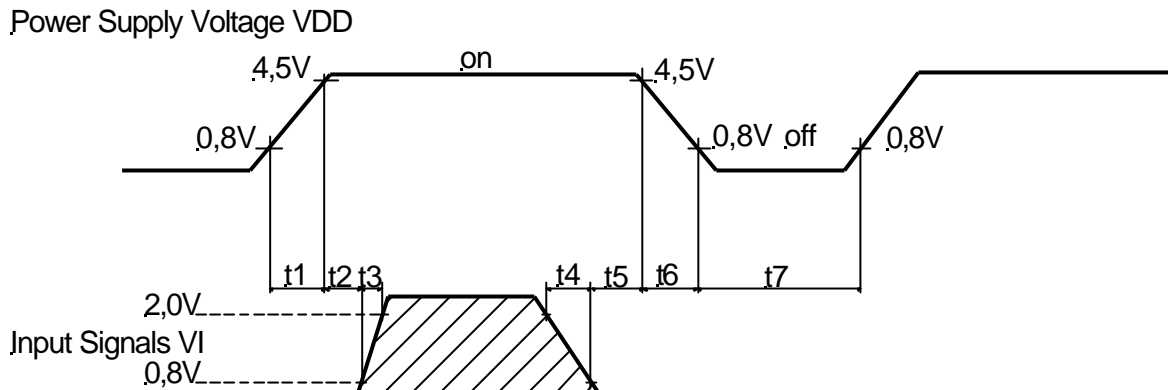

$$0 \text{ ms} < t4 \leq 3 \text{ ms}$$

$$0 \text{ ms} < t2 \leq 50 \text{ ms}$$

$$0 \text{ ms} < t3 \leq 3 \text{ ms}$$

$$t1 \leq 40 \text{ ms}$$

$$0 \text{ ms} < t5 \leq 50 \text{ ms}$$

$$0 \text{ ms} < t6 \leq 1 \text{ s}$$

$$t7 \geq 0.2 \text{ s}$$

Power ON OFF

Notes

- 1) Set $0V \leq VI(t) \leq VDD(t)$
Here, $VI(t)$, $VDD(t)$ indicate the transitive state of VI, VDD when power supply is turned ON or OFF.
- 2) Do not keep interface signal high-impedance when power on.

7.10 OPTICAL CHARACTERISTICS

Measuring equipment:

Luminance, Chromaticity: TOPCON BM-7

Viewing Angle, Contrast: ELDIM EZContrast 160D

Ta = 25°C ± 2°C, VDD = 5 V, fv = 60 Hz, f_{DCLK} = 32.5 MHz

Parameter	Symbol	Condition	Min.	Typ.	Max.	Unit	Remark	
Viewing Angle	Horizontal	Øx+	CR>10, Øy = ±0°	-	75	-	deg.	(1), (4)
		Øx-	CR>10, Øy = ±0°	-	75	-	deg.	
	Vertical	Øy+	CR>10, Øx = ±0°	-	50	-	deg.	
		Øy-	CR>10, Øx = ±0°	-	55	-	deg.	
Contrast ratio	CR	Øy=-5°, Øx=±0°	-	400:1	-	-	(1), (2), (4)	
Response time	T _R	rising	-	45	-	ms	(1), (3)	
	T _F	falling	-	45	-	ms		
Luminance (center of screen)	Lw	at center	-	800	-	cd/m ²	(1), (4)	
Dimming range	DR			1:5			(1), (4)	
Chromaticity	Red	Rx	at center	-	tbd	-	-	(1), (4)
		Ry		-		-		
	Green	Gx	at center	-	tbd	-	-	
		Gy		-		-		
	Blue	Bx	at center	-	tbd	-	-	
		By		-		-		
	White	Wx	at center	-	tbd	-	-	
		Wy		-		-		

note (1): Definition of viewing angle

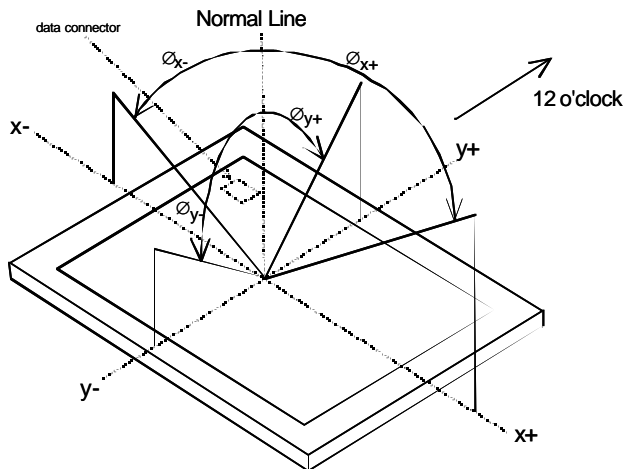

(2): The contrast ratio is calculated by using the following formula:

$$\text{Contrast ratio} = \frac{\text{Brightness (Luminance) with all pixels in "White"}}{\text{Brightness(Luminance) with all pixels in "Black"}}$$

the brightness is measured in a darkroom.

note (3): Definition of the response time:

Photodetector output signal is measured when the brightness changes from "white" to "black" or "black" to "white" respectively. The response time is the time between 10% and 90% of the photodetector output.

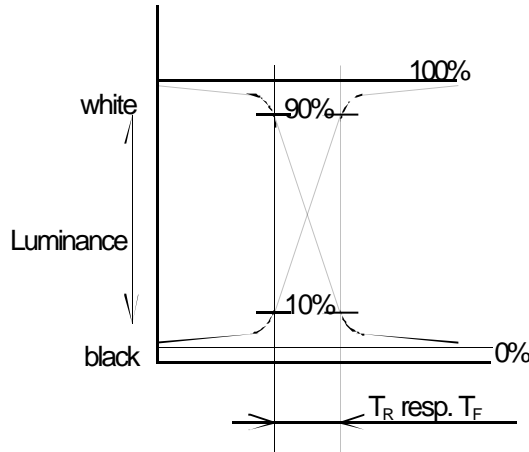

note (4): Brightness measurements setup

The measurement should be executed in a dark room 30 min. after lightning the backlight. Matrix: off state. The brightness is measured in the center of the screen.

Environment condition: $T = 25 \pm 2 \text{ } ^\circ\text{C}$, it has to be assured that a sufficient heat flow / air circulation is given

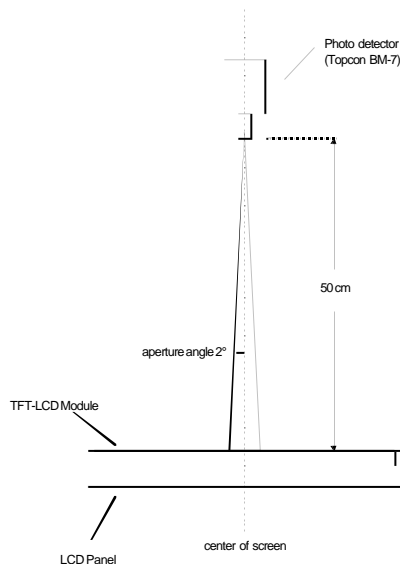

7.11 INVERTER SPECIFICATION

I General

- I.1 Features
- without housing
 - with PWM dimming control interface
 - with power-safe-mode control interface
 - programmable operating parameter
- I.2 Dimming range 100 ... 20%

II Mechanical specification

- II.1 Dimensions 200 x 40 x 20 L x W x H
 Weight < 150 g
 Mounting 4 holes in PCB
 Electrical interfaces DC input: WAGO RM 5 terminal block
 Lamp: Molex connector
 Control: AMP 8-215079-4

III Electrical specification

- III.1 Input voltage 24 V DC 20 V ... 30 V; stabilized
 undervoltage lockout
 at 19.9 V
- III.2 Rated input current 1.67 A 24 V
- III.3 Rated system power 40 W max. 45 W with fan
- III.4 System power at Stand by < 15 W
- III.5 Lamp voltage frequency 40 ... 80 kHz

IV Control interface

- IV.1 Dimming signal 100 ... 20%, PWM signal
- IV.2 Duty cycle $\leq 10\% \Rightarrow$ max. luminance
 $= 90\% \Rightarrow$ min. luminance
- IV.3 PWM level 4 ... 6 V_S R_i \geq 600 Ω
- IV.4 PWM frequency typ. 255 Hz 230 Hz ... 300 Hz
- IV.5 Sync. signal level 4 ... 6 V_S R_i \geq 600 Ω
- IV.6 Sync. frequency 255 Hz 64 Hz min. pulsewidth 0.35 ms
- IV.7 Power save enable 0 ... 1 V DC lamp on
 4 ... 6 V DC lamp off, R_i \geq 600 Ω
- IV.8 Open circuit protection yes
- IV.9 Short circuit protection no
- IV.10 Over temperature protection yes with thermal switch
 or NTC

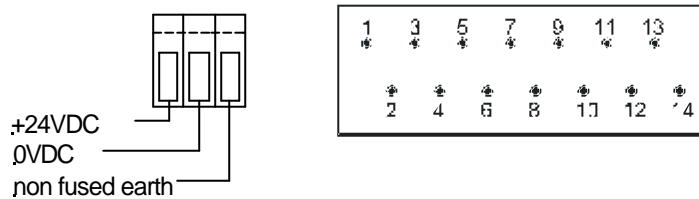
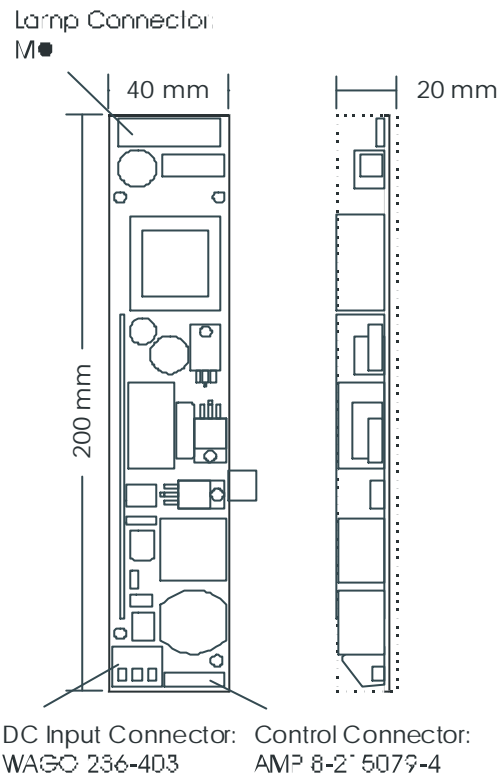

Important! non-fused earth has to be connected to low impedance ground potential. Be sure to have a valid ground concept.

Pin Connection

Power connector	Wago 236-403		
	+24 VDC	0VDC	Earth
Control interface	Connector AMP 8-215079-4		
	Inputs (+ 5 V)		Outputs
	5 DIM GND	1 +15 V/50 mA	3
	6 DIM +	2 0V	4
	9 PSE GND		7
10 PSE +		8	
			11
			12
			13
			14
	DIM: dimming		
	PSE: power save enable		

VI PWM - signal for dimming

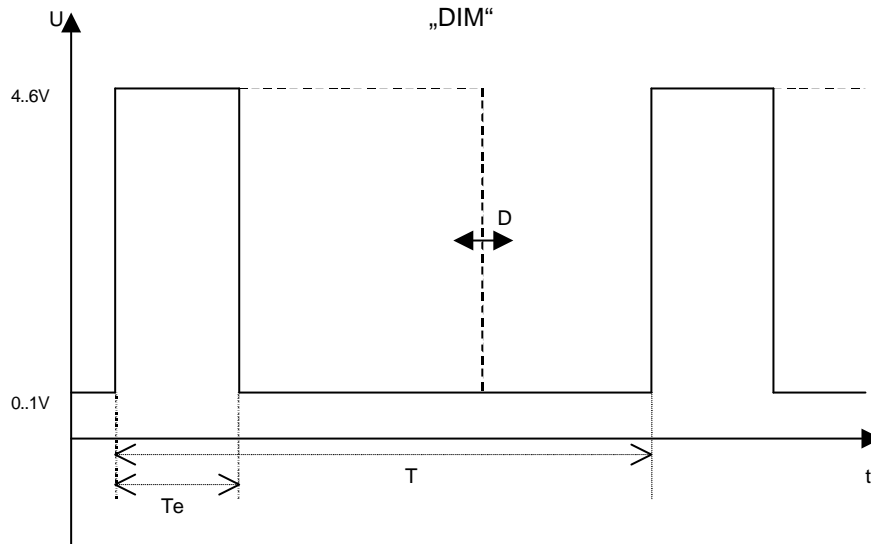

PWM Frequency	PWM Duty Cycle	PWM Levels
$T^{-1} = f = 230 - 300 \text{ Hz}$ Typ = 255 Hz	$D = T_e / T$ $D \leq 0.1 \leftrightarrow \text{max.Luminance}$ $D > 0.1 \leftrightarrow \text{PWM-Dimming}$	Low: 0 - 1 V High: 4 - 6 V

7.1.2 OUTLINE DIMENSION

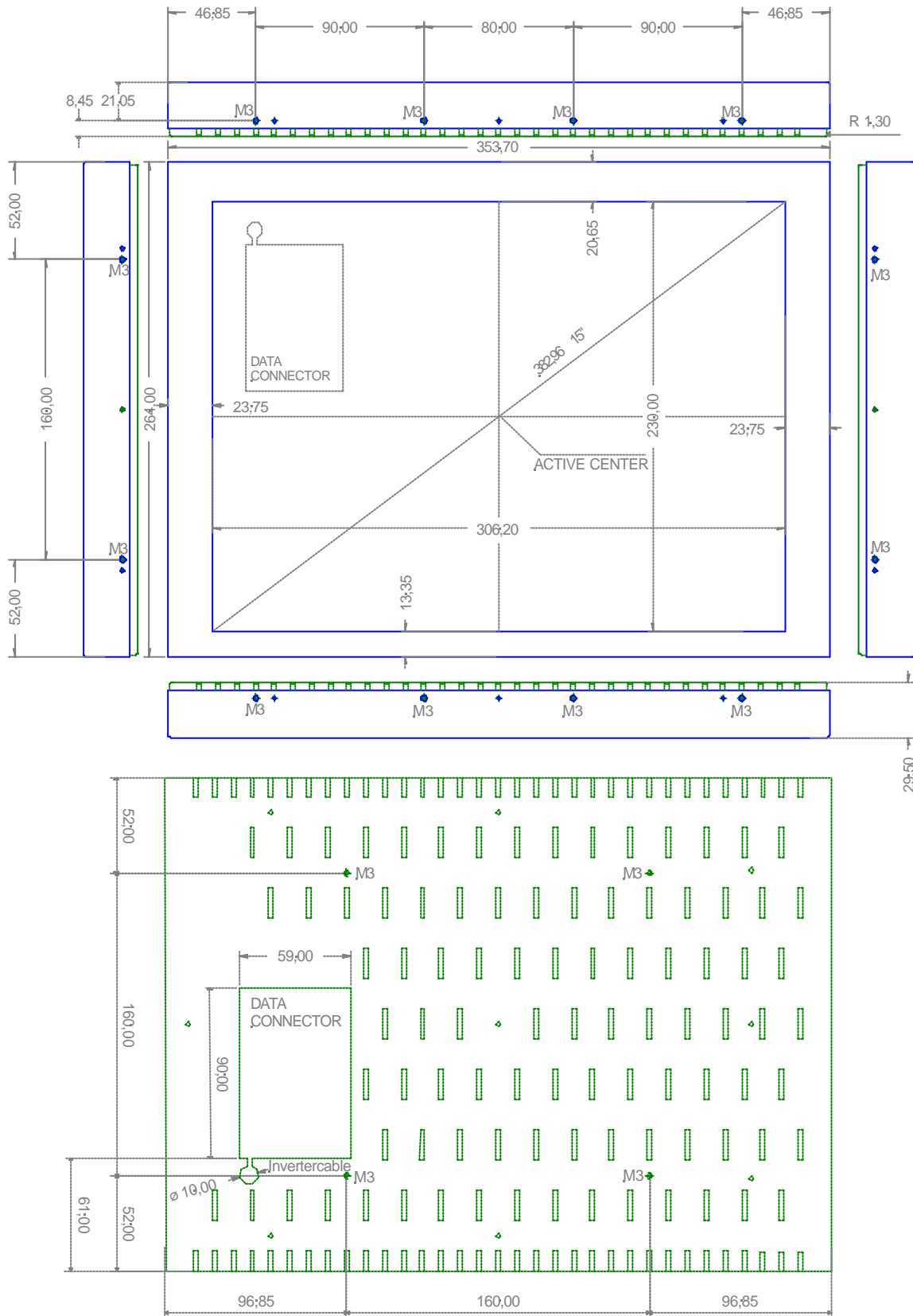

SIEMENS

8. GENERAL PRECAUTIONS

8.1 HANDLING

- (a) When the module is assembled, it should be attached to the system firmly using every mounting holes. Be careful not to twist and bend the modules.
- (b) Refrain from strong mechanical shock and / or any force to the module. In addition to damage, this may cause improper operation or damage to the module and CCFT backlight.
- (c) Note that polarizers are very fragile and could be easily damaged. Do not press or scratch the surface harder than a HB pencil lead.
- (d) Wipe off water droplets or oil immediately. If you leave the droplets for a long time, staining and discoloration may occur.
- (e) If the surface of the polarizer is dirty, clean it using some absorbent cotton or soft cloth.
- (f) The desirable cleaners are water, IPA (Isopropyl Alcohol) or Hexane. Do not use Ketone type materials (ex. Acetone), Ethyl alcohol, Toluene, Ethyl acid or Methyl chloride. It might produce a permanent damage to the polarizer due to chemical reaction.
- (g) If the liquid crystal material leaks from the panel, it should be kept away from the eyes or mouth. In case of contact with hands, legs or clothes, it must be washed away thoroughly with soap.
- (h) Protect the module from static, it may cause damage to the C-MOS Gate Array IC.
- (i) Use finger-stalls with soft gloves in order to keep display clean during the incoming inspection and assembly process.
- (j) Do not disassemble the module.
- (k) Pins of I/F connector shall not be touched directly with bare hands.

8.2 STORAGE

- (a) Do not store the TFT-LCD module in direct sunlight.
- (b) The module shall be stored in a dark place. It is prohibited to apply sunlight or fluorescent light during the store.

8.3 OPERATION

- (a) Do not connect, disconnect the module in the "Power On" mode.
- (b) Power supply should always be turned on/off by following item 6.6 "Power on/off sequence".
- (c) Module has high frequency circuits. Sufficient suppression to the electromagnetic interference shall be done by system manufacturers. Grounding and shielding methods may be important to minimize the interference.

8.4 OTHERS

- (a) Ultra-violet ray filter is necessary for outdoor operation.
- (b) Avoid condensation of water. It may result in improper operation or disconnection of electrode.
- (c) Do not exceed the absolute maximum rating values (the supply voltage variation, input voltage variation, variation in part contents and environmental temperature, so on). Otherwise the module may be damaged.
- (d) If the module displays the same pattern continuously for a long period of time, it can be the situation when the image "sticks" to the screen.
- (e) This module has its circuitry PCB's on the rear side and should be handled carefully in order not to be stressed.

9. COSMETIC SPECIFICATIONS

9.1 VISUAL INSPECTION

1) INSPECTED AREA

- i) The distance between inspector`s eyes and the module is around 300mm.
Viewing angle for inspection is as follows:
 $q \leq 45^\circ$ when non - operating inspection.
 $q \leq 5^\circ$ when operating inspection.
- ii) Inspection should be executed only from front side, and only for A - zone.
The visual defects of B & C - zone are ignored (refer to 9.2 DEFINITION OF ZONE)

2) ENVIRONMENTAL

- i) Ambient temperatur: 25°C
- ii) Illumination for inspection should be around 2000 (lx) in the module operation and around 1000 (lx) in non-operation.
- iii) Back-light is powered on in the inspection for module operation.

3) OPERATING INSPECTION

Number of display colors in the inspection is 8 only (Gray scale 0 and 255 for each Red, Green, Blue, and White).

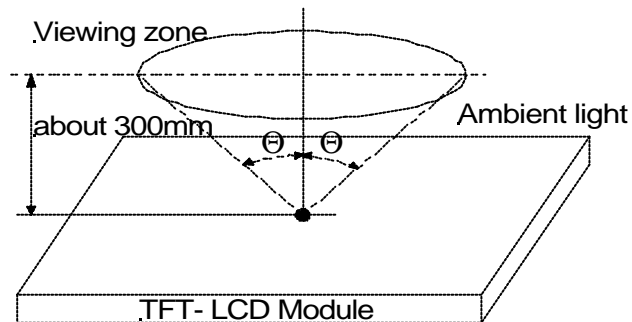

9.2 DEFINITION OF ZONE

Each zone is defined as follows. The visual defects are specified at A - zone and the specification is not applicable to B & C - zone. (Defects in B&C-zone are disregarded).

- A-zone: Display area (pixel area)
- B-zone: Area between A-zone and C-zone
- C-zone: Metallic bezel area (include I/F connector)

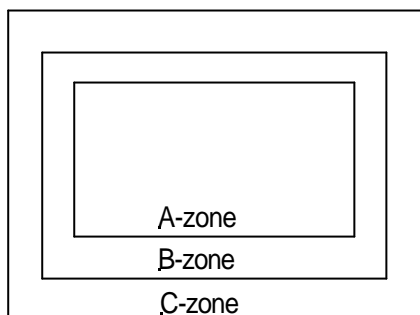

SIEMENS

9.3 COSMETIC SPECIFICATION

The following are inspected at the module stable operation and defects appearing at powered on & off is disregard.

	No.	ITEM			Maximum Acceptable Number		Note	
					A-zone	Unit		
Operating Inspection	1	Dot Defect	Sparkle Mode	1 dot	7	pcs	1),2),4)	
				2 dot	3	Unit	1),2),5)	
				3 dot	0			
				4 dot	0			
				Density	0	pcs/Ø20mm	1),2),6)	
			Total	7	pcs	1),2)		
			Black Mode	1 dot	7	pcs	1),3),4)	
				2 dot	3	Unit	1),3),5)	
				3 dot	0			
				4 dot	0			
				Density	3	pcs/Ø30mm	1),3),6)	
			Total	7	pcs	1),3)		
			Total	7	pcs	1)		
	2	Line Defect			Serious one is			
	3	Uneven brightness			Not allowed		-	-
	4	Stain Inclusion	W < 0.02	L:Ignore	Ignore		pcs	7)
				W < 0.04	L < 2.0	10		
			W < 0.08		L < 1.0	10		
				W > 0.08	L > 1.0	0		
			-		-	see Dot shape		
	5	Stain Inclusion	D ≤ 0.24		Ignore		pcs	7)
			D ≤ 0.4		5			
			D > 0.4		0			
	6	Scratch on polarizer	W < 0.01	L:ignore	Ignore		Pcs	8)
				W < 0.02	L ≤ 40	10		
			W < 0.04		L > 40	0		
				L: length(mm)	L ≤ 20	10		
L > 20			0					
7	Scratch on polarizer	D ≤ 0.2		Ignore		pcs	8)	
		D ≤ 0.4		10				
		D > 0.4		0				
8	Bubbles, Peeling in Polarizer	D ≤ 0.3		Ignore		pcs	8)	
		D ≤ 0.5		10				
		D ≤ 1.0		5				
		D > 1.0		0				
9	Wrinkles on Polarizer			Serious one is		-	-	
					Not allowed			

Notes

- 1) Defect whose area per each dot is over 50% is regarded as Dot Defect.
- 2) Defect whose brightness at all black screen is more than 30% is regarded as Bright Dot Defect.
- 3) Defect whose brightness at all white screen is less than 70% is regarded as Dark Dot Defect.
- 4) Defect dots which are not adjacent are regarded as Single Dot Defect each.
- 5) 2 or more Adjacent Defect dots is regarded as n(number)-Adjacent Dot Defect.
- 6) Defect density is defined by the number of defects existing in the 20mm Ø.
- 7) Defect which can be easily wiped off is disregarded.
- 8) The specification is applicable only to A-zone and if these defects are in B-zone, they are disregarded.
- 9) In case of gray scale pattern, obvious defects is to be rejected.