

Gas Detection Monitor

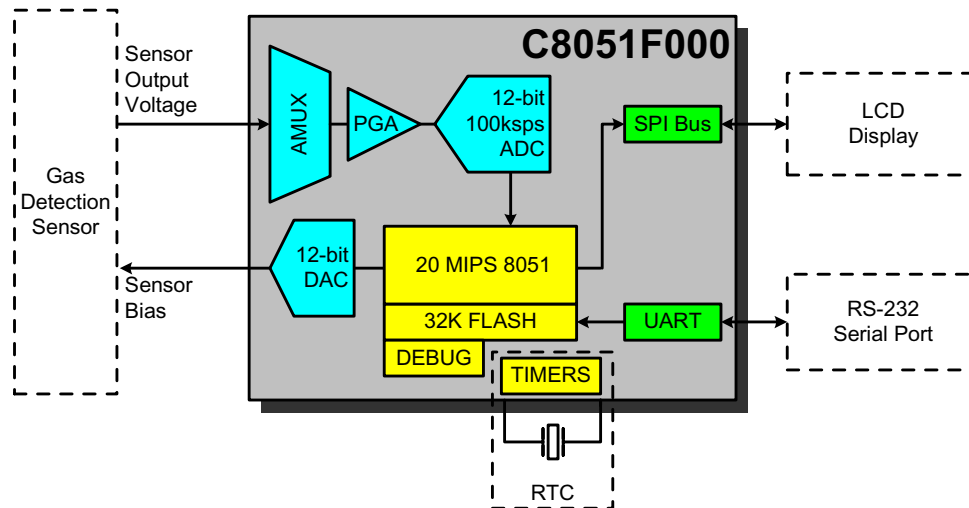

Background

Gas detection monitors interface with sensors to measure gas concentrations. The monitor typically provides the sensor bias voltage, measures the sensor output voltage, computes gas concentrations, and communicates with display peripherals. Common applications require monitors to generate alarms when gas concentrations reach a specified level.

Cygnal Application

Cygnal's C8051F000 is an in-system programmable, mixed-signal system-on-a-chip device that can perform most functions of a gas detection monitor--all on a single device.

The on-chip 12-bit ADC provides precision voltage measurements at up to 100 ksps, with programmable out-of-range detection. The integrated programmable gain amplifier (PGA) allows input voltage conditioning to compensate for changing sensor characteristics. One of the two on-board 12-bit DACs can be used to generate the sensor excitation voltage.

With the addition of an external watch crystal, one of the four on-board timers can provide real-time clock functionality for sampling, calibration requests, or time-

stamping. For low power consumption, the system clock may be switched to the watch crystal when high throughput is not necessary. An on-chip power supply monitor is also provided.

Key Benefits

- 100 ksps, 12-bit ADC provides precision sensor voltage measurements.
- The ADC's Programmable Window Detector continuously checks the ADC measurement against a specified range without software intervention.
- The PGA facilitates ADC input voltage conditioning, to compensate as the sensor voltage offset changes with age.
- FLASH may be written from application code, allowing calibration constants to be stored in non-volatile memory, and software updates to be loaded via one of the serial communication interfaces (UART, SPI, SMBus).
- In-system programmability allows software to be updated for sensor changes or upgrades, *and debugged with the device installed in the end-application.*