



---

## AN015 - Software UART Examples

---

### Relevant Devices

This application note applies to the following devices:

C8051F000, C8051F001, C8051F002, C8051F005, C8051F006, C8051F010, C8051F011, C8051F012, C8051F012, C8051F015, C8051F016, C8051F017, C8051F220, C8051F221, C8051F226, C8051F230, C8051F231, C8051F236.

---

### Introduction

This application note presents a discussion about software UART implementation on C8051Fxxx devices. Two complete examples are given: a C program using the PCA as the baud rate source, and an assembly program using Timer 0 as the baud rate source.

### Key Features

The two software examples were designed to closely mimic the hardware UART while still preserving hardware resources and CPU bandwidth. The following is a list of key features found in both examples:

- An interface similar to the hardware UART, with user-level transmit and receive interrupts.
- Interrupt or polled mode access support.
- Full-duplex communication up to 57.6 kbps using an 18.432 MHz clock source.
- State-based, interrupt-driven implementation, requiring minimal CPU overhead.
- Minimal hardware usage:
  - 'C' example uses two PCA modules.
  - Assembly example uses Timer 0 in Mode 3.

### Implementation Options

The essential trade-off to consider when implementing a software UART (SW UART) is between hardware usage and speed/efficiency. Designs that utilize more hardware are likely to consume less CPU bandwidth and allow higher bit rates. This trade-off is discussed below.

#### **Baud Rate Sources**

An interrupt must be generated for each bit that is transferred; at a full-duplex 115.2 kbps, that's an interrupt every 4.3  $\mu$ s. The method of generating these interrupts (baud rate source) determines to a large extent how much overhead the implementation consumes. Available options include: 8-bit timers, 16-bit timers, and the Programmable Counter Array (PCA). Note that for full-duplex operation, two baud rate sources are required (one each for transmit and receive).

The use of 8-bit timers allows one of the 16-bit hardware timers to be used for both transmit and receive baud rate generation. Timer 0 offers this capability in Mode 3. Note that when Timer 0 is in this mode, Timer 1 functionality is reduced; however, Timer 1 may still provide baud rate generation for the hardware UART (HW UART). Using 8-bit timers



preserves hardware resources, but does introduce some overhead and latency issues. These issues are discussed in Example 2.

An alternative to the above solution is the use of 16-bit auto-reload timers. In this case two of the 16 bit hardware timers are occupied by the SW UART--one for transmit and one for receive. Any of the available timers will suffice, but the auto-reload feature on Timer 2 and Timer 3 reduces overhead, and eliminates any interrupt latency issues. Additionally, 16-bit timers support a wider range of baud rates.

The Programmable Counter Array (PCA) also provides an excellent solution for the SW UART, as demonstrated in the provided 'C' example. The PCA consists of a dedicated 16-bit counter/timer and five 16-bit capture/compare modules. Each of these modules may be configured to trigger an interrupt when the PCA counter matches the associated compare module's contents. Since the PCA counter runs uninterrupted, this solution avoids the problem of accumulated interrupt latency. The PCA implementation is not available on C8051F2xx devices.

### ***Additional Considerations***

Each of the above timer sources may be clocked by SYSCLK or an external signal. In the provided examples, baud rate sources are clocked by SYSCLK, which is derived from an external 18.432 MHz crystal. Any baud rate/crystal frequency combination is allowed, though software overhead limits the maximum baud rate-to-SYSCLK ratio.

START bit detection is also a concern for the SW UART receiver. C8051F00x and C8051F01x devices offer many external interrupt sources, several of which can be configured to detect falling edges. Both example

programs utilize external interrupts for START detection.

## **Example 1: Programmable Counter Array Implementation**

Example 1 uses two PCA modules to generate the receive and transmit baud rates (modules 0 and 1, respectively). The modules are configured in software timer mode to generate baud rate interrupts. An introduction to the PCA can be found in AN007.

### ***Program Structure***

In software timer mode, the PCA can generate an interrupt when the PCA counter matches a value in one of the compare modules. Since the PCA counter runs uninterrupted, the modules can be updated each bit time to accurately produce the next bit time. In addition, the PCA offers a capture function that is useful in START bit detection.

The PCA modules may be routed via the crossbar to external signals. These signals (called CEXn for module n) can be used to trigger PCA counter captures. This feature is exploited in the SW UART receiver. START bit recognition is accomplished with module 0 configured to capture the PCA counter contents upon a falling edge on the RX pin. This function offers two benefits: (1) START bit detection is easily accomplished; and (2) since the capture is performed immediately as the edge is detected, the bit sample timing is immune to interrupt latency.

### ***Implementation***

The transmit and receive operations for Example 1 are implemented as two indepen-

**Figure 1. Transmit and Receive State Machines**

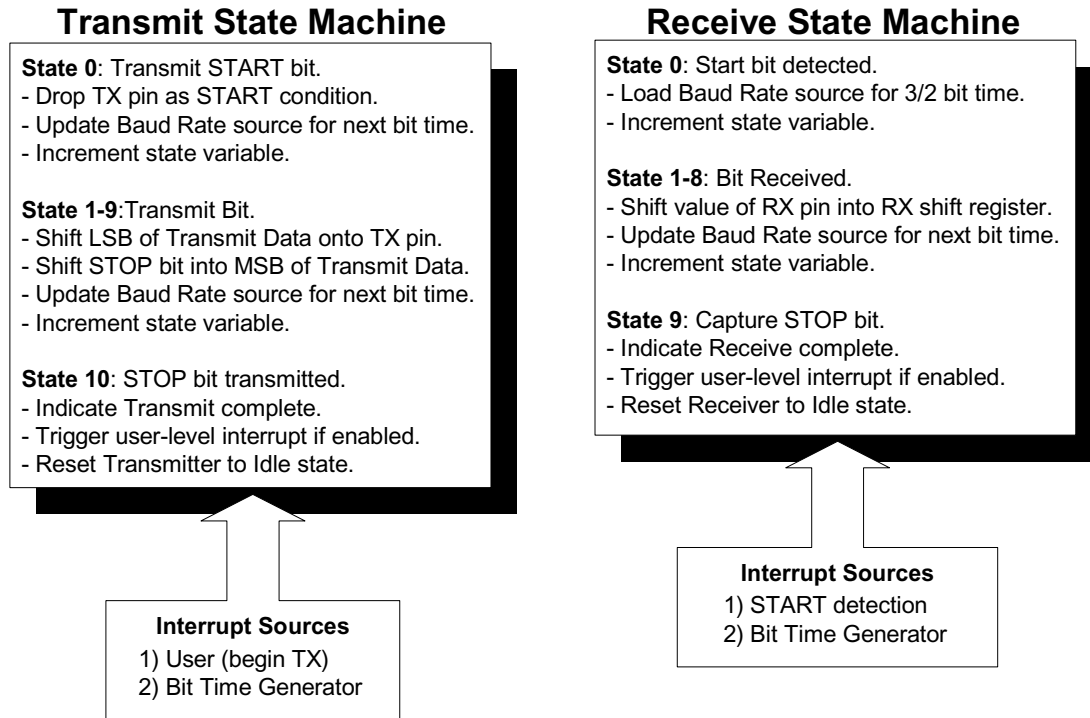

dent state machines in the PCA ISR. The state machines are illustrated in Figure 1.

### Receive State Machine

When the SW UART is initialized, the PCA module 0 is configured for negative-edge capture mode. Its input, CEX0, is routed via the crossbar to a GPIO pin (P0.2, SW\_RX). With the state machine in State 0, an interrupt is generated when a falling edge is detected on SW\_RX. Since the module is in capture mode, the contents of the PCA counter are loaded into the module 0 capture registers. Note that

this value is independent of interrupt latency. Module 0 is switched to software timer mode after the START bit is detected, and 3/2 bit-time is added to the module 0 capture register. The extra 1/2 bit-time is used only after the start bit is detected, so that sampling will occur during the middle of the next bit period (see Figure 2). When the PCA counter reaches the value held in the module 0 capture registers, the first bit-sampling interrupt (LSB in this case) occurs.

**Figure 2. SW UART Bit Timing**

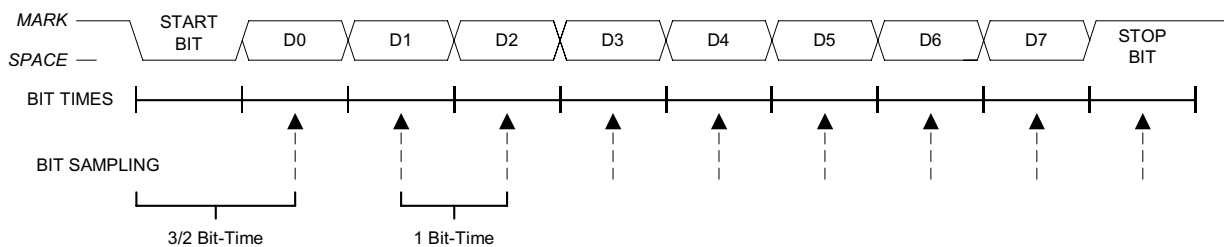



States 1-8 execute on module match interrupts. In each state, bits are sampled from SW\_RX and shifted into the RXSHIFT variable. The PCA module 0 contents are updated in each state to provide the next bit-time interrupt (1 bit time is added to the compare registers). The state variable is also incremented.

State 9 captures the STOP bit, posts SRI, and returns the receiver to Idle state.

### Transmit State Machine

A user initiates a transmit by forcing a PCA module 1 interrupt (setting CCF1=1). In State 0, the TX pin is forced low to generate the START condition. The PCA counter is read, and this value plus one bit-time is loaded into to the module 1 capture registers. Note that a few SYSCLKs will pass between the time the START bit is generated and when the PCA counter is read. This is the only instance in Example 1 where interrupt latency affects the bit time. The effect is negligible (worst case ~ 1/16 bit-time for 57.6 kbps and an 18.432 MHz SYSCLK).

States 1-9 are executed on module match interrupts. In each state, a bit is shifted out of the LSB of TDR, and a '1' shifted in the MSB of TDR to represent the STOP bit. One bit time is added to the PCA module 1 capture registers to generate the next bit time. After 9 shifts, the data byte + STOP bit have been transmitted. The Transmit Complete indicator (STI) is set, the Transmit Busy indicator (STXBSY) is cleared, and the TX state variable is reset.

### Program Interface

The SW UART supports both polled and interrupt-driven interfacing. Polled support is configured by disabling user-level interrupts (SES=0). The transmit and receive indicators (STI and SRI, respectively) can then be polled for transfer completions. The initialization and

polled mode programming procedure for Example 1 is shown in Figure 3.

**Figure 3. Example 1 User-Level Polled Mode Interface**

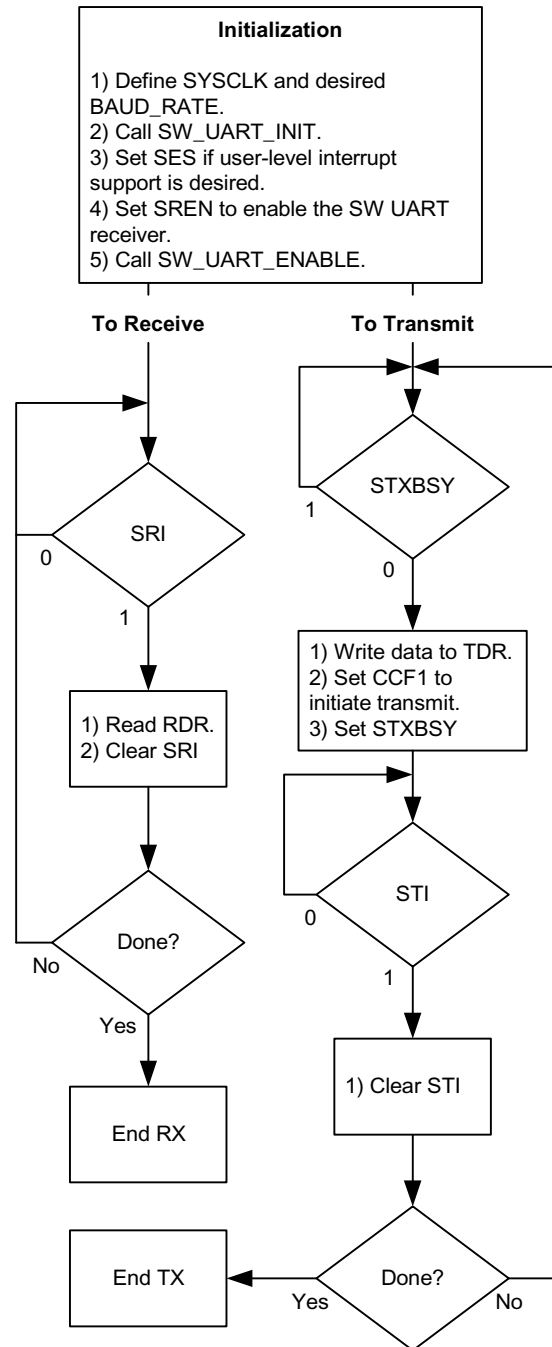



## AN015 - Software UART Examples

The initialization routine, SW\_UART\_INIT, configures the PCA, interrupts, and state variables for use in the SW UART. The SW\_UART\_ENABLE routine enables the SW UART. The SREN bit must be set to enable the receiver. Note that the TIME\_COUNT constant is calculated by the software from the BAUD\_RATE and SYSCLK constants.

**Figure 4. Example 1 User-Level Interrupt Mode Interface**

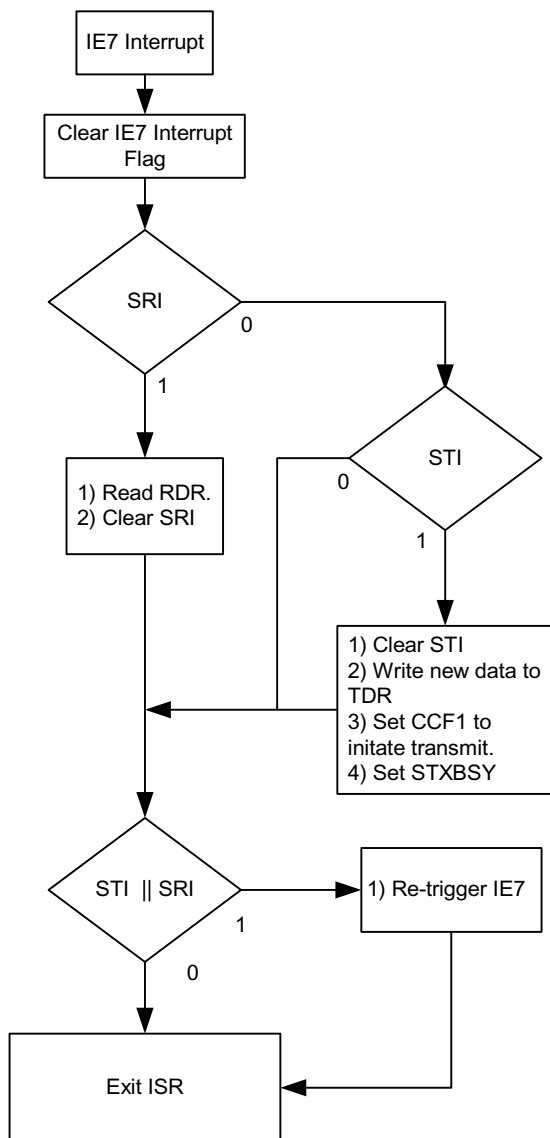

To use the software in interrupt mode, set SES=1. The programming procedure for interrupt mode is shown in Figure 4.

If user-level interrupt support is enabled (SES=1), an IE7 interrupt is generated each time a transmit or receive is completed. As with the hardware UART, user software must check the transmit/receive complete flags to determine the source of the interrupt. In the event that a transmit and receive are completed simultaneously, the user software will receive only one interrupt. The IE7 ISR must be capable of handling this situation. Two options are available: (1) service both transmit and receive in the same ISR execution, or (2) service one (STI or SRI) and force an interrupt so that the ISR is called again to service the other. The second option is recommended to minimize ISR execution time.

Test code is provided to interface the SW UART with the HW UART. Connect jumper wires as shown in Figure 5.

**Figure 5. Example 1 Test Configuration**

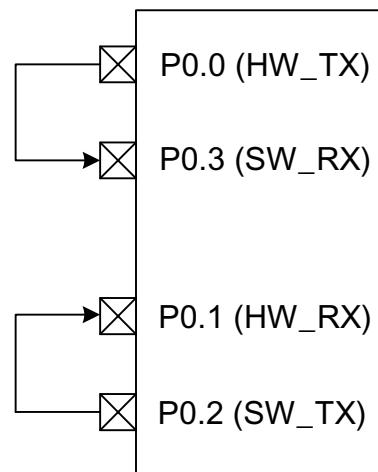

The test code routines configure and enable the HW UART in Mode 1 using Timer 1 as the



baud rate source. Timer 1 is also configured. Different baud rates and crystals may be tested by changing the BAUD\_RATE and SYSCLK constants. Both HW and SW UART baud rate counts are calculated by the software from these constants. The testing routines transmit 15 characters in both directions.

To test the SW UART in polled mode, comment the line

```
; INTERRUPT_TEST();
```

and uncomment the line

```
POLLED_TEST();
```

Reverse the above steps to test the SW UART in interrupt mode. Uncomment the line

```
INTERRUPT_TEST();
```

And comment the line

```
; POLLED_TEST();
```

The longest states in Example 2 require 113 SYSCLKs (TX States 1-9). For an 18.432 MHz crystal, a SW UART transmit or receive operation will require a worst case 6  $\mu$ s per bit transferred ( $113 * T_{SYSCLK}$ ). At 57.6 kbps, that's ~35% of CPU bandwidth for a transmit or receive (70% for full-duplex). For the Example 1 software compiled with the Keil compiler, the full-duplex overhead may be approximated by the following equation:

$$FD \text{ Overhead}(\%) \sim = BAUD\_RATE/81,000$$

Per the above equation, baud rates above 80 kbps are not supported for full duplex operation. The overhead penalty is only incurred while the SW UART is performing a transfer. The code listing begins on page 10.

## Example 2: 8-Bit Timer Implementation

In Example 1 the SW UART uses Timer 0 in Mode 3. In this mode, Timer 0 is split into two 8-bit timers: one is used for transmitting and one for receiving. TL0 is used as the receive timer; TH0 is used as the transmit timer.

With Timer 0 in Mode 3, Timer 1 may not set the TF1 flag, generate an interrupt, or be clocked by external signals. However, Timer 1 may still operate as a baud rate generator for the HW UART if configured in Mode 2 (8-bit timer w/auto-reload). While Timer 0 is in Mode 3, Timer 1 may be enabled/disabled through its mode settings. Timer 1 is disabled in Mode 3, and enabled in all other modes.

With Timer 1 as the HW UART baud rate source, this solution is perhaps the most efficient use of hardware resources. The downside is increased software overhead (relative to the 16-bit timer solution). Timer 0 Mode 3 does not offer auto-reload capabilities; the manual timer reload requires a 16-bit move in each interrupt service routine (ISR) iteration. In addition, interrupt latency will affect the bit-time accuracy. A correction constant can be factored into the timer preload values to compensate for typical interrupt latency, but variations in interrupt latency are unaccounted for.

Slower baud rates may require more than 8-bits of timer counts for each bit time. With SYSCLK at 18.432 MHz and Timer 0 in SYSCLK/1 mode, baud rates below 72 kbps require more than 256 timer counts. Available options include:

- 1) Use Timer 0 in SYSCLK/12 mode. Slower baud rates may be achieved with 8 bits, but standard baud rate/SYSCLK combinations are more difficult to obtain.



## AN015 - Software UART Examples

2) Use Timer 0 in SYSCLK/1 mode, and keep an upper timer byte manually in the timer ISR. Note that this method will generate an interrupt every 256 SYSCLKs for each transmit and receive, regardless of the baud rate (an interrupt each time the lower 8-bits overflow). The Example 2 software demonstrates option #2.

### Program Structure

The transmit and receive operations for Example 2 are implemented as two independent state machines in the Timer 0 and Timer 1 ISRs (see Figure 1 on page 3). The Timer 0 ISR is used to manage the receive state machine; the Timer 1 ISR manages the transmit state machine. The /INT0 ISR starts the receive state machine, but is disabled when the receive state is non-zero.

The SW UART receiver captures the START bit using an external interrupt source, /INT0, configured for active-low edge-sensitive input. The /INT0 interrupt is enabled when waiting for a START bit, and disabled during transfers. /INT0 is routed to the GPIO pins via the crossbar. Details on crossbar configuration can be found in AN001.

Since all timer loading is performed manually in the ISR, interrupt latency must be compensated for. A 'slop constant' is subtracted from each timer preload value to adjust for this interrupt latency and code executed between the timer overflow and the operation of reloading the new timer values. These constants are independent of the SYSCLK frequency or baud rate; however, they do not account for variations in interrupt latency.

### Implementation

NOTE: For this discussion, assume the baud rate is slow enough that the 8-bit timers are not

sufficient. The direct RAM bytes labeled BCRHI and BCTHI are used to manually keep the upper bytes for the receive and transmit timers, respectively.

#### Transmit State Machine

When the SW UART is initialized and enabled, the TX interrupt is set pending but still disabled. The user initiates the transfer by enabling the transmit interrupt (Note that TH0, the upper byte of Timer 0, generates the TX interrupts).

In State 0, the TX pin is asserted low to produce the START condition, and the timer is loaded with 1 bit time to produce the next interrupt.

```
; Load high byte into BCTHI
mov  BCTHI, #HIGH(TX_BT);
; Load low byte into TH0
mov  TH0, #-LOW(TX_BT);
```

Notice that BCTHI is loaded with the unsigned bit-time high byte, but TH0 is loaded with the negative of the bit-time low byte. This is because Timer 0 (as all hardware timers) is an up-counter, while BCTHI counts down. TH0 will overflow and generate an interrupt as it overflows from 0xFF to 0x00; BCTHI is decremented upon each interrupt, and indicates a bit time when it equals zero.

For States 1-9, one state is executed each time BCTHI reaches zero. In each State, the LSB of the Transmit data register (TDR) is shifted onto the TX pin. The TX timer is loaded with 1 bit time, and a '1' is shifted into the MSB of TDR to represent the STOP bit in State 9 (TDR should hold 0xFF after the transfer is complete).

State 10 sets the Transmit Complete indicator (STI), clears the Transmit Busy indicator



(STXBSY), and triggers an IE7 interrupt if user-level interrupt support is enabled.

## Receive State Machine

In State 0, /INT0 is used as the RX input (configured falling-edge active, HIGH priority). An /INT0 interrupt means a START condition has been detected. The /INT0 ISR loads the RX timer (TL0 + BCRHI) with 3/2 bit-time (see Figure 2). BCRHI is decremented each time TL0 overflows.

States 1-8 execute when BCRHI reaches zero. In each state, the SW\_RX pin is sampled and shifted into the LSB of the RXSHIFT variable. The RX timer is also reloaded to generate the next sampling time. State 9 captures the STOP bit, but framing error detection is not provided (the STOP bit polarity is not checked). If user-level interrupts are enabled, this state enables and triggers the IE7 interrupt.

## Program Interface

Example 2 supports both polled and interrupt driven interfacing. The initialization ritual and programming procedure for polled mode is shown in Figure 6. The TIME\_COUNT constant must be explicitly defined in this example.

**Figure 6. Example 2 User-Level Polled Mode Interface**

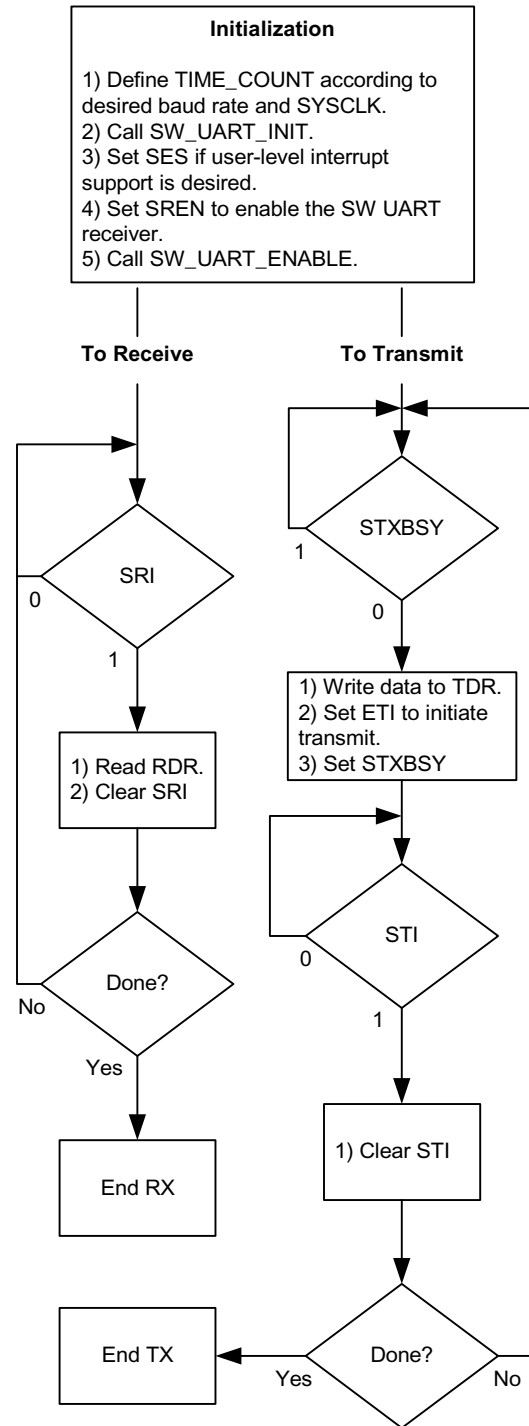



## AN015 - Software UART Examples

Figure 7 shows the IE7 ISR programming sequence for interrupt mode. Note that the receive operation is serviced first, since it is the most sensitive to latency.

**Figure 7. Example 2 User-Level Interrupt Interface**

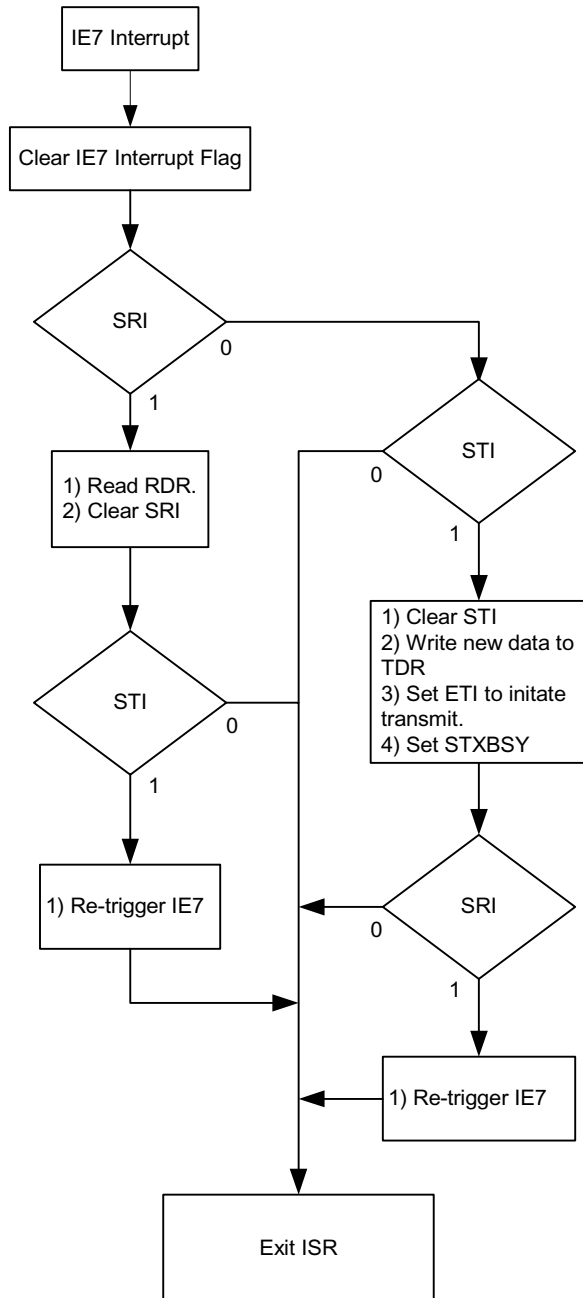

To handle the situation of a transmit and receive completing simultaneously, this example services one function and re-triggers itself to service the other.

Test code is provided. To test the polled mode code, in the MAIN routine uncomment the line

```
ajmp PolledRX_PolledTX
```

and comment the line

```
; ajmp InterruptRX_InterruptTX
```

To run the interrupt mode test code, reverse the above steps. Comment the line

```
; ajmp PolledRX_PolledTX
```

and uncomment the line

```
ajmp InterruptRX_InterruptTX
```

Adding a jumper wire between SW\_GPIO\_TX and SW\_GPIO\_RX provides quick and easy evaluation of the SW UART. Note that this evaluation method is only useful with the interrupt mode test code.

With a SYSCLK of 18.432 MHz, the software given in Example 2 operates in full-duplex at a maximum of 57.6 kbps. The code listing begins on page 21.

# AN015 - Software UART Examples



```
//-----  
//  
// Copyright 2001 Cygnal Integrated Products, Inc.  
//  
// FILE NAME: AN015_1.c  
// TARGET DEVICE: C8051F00x, C8051F01x  
// CREATED ON: 03/10/01  
// CREATED BY: JS  
//  
// Software UART program, using PCA as baud rate source.  
// PCA module 0 is used as receive baud rate source and START detector. For START  
// detection, module 0 is configured in negative-edge capture mode. For all other  
// SW_UART operations, module 0 is configured as a software timer. Module match  
// interrupts are used to generate the baud rate. Module 1 generates the transmit  
// baud rate in software timer mode.  
// Code assumes an external crystal is attached between the XTAL1 and XTAL2 pins.  
// The frequency of the external crystal should be defined in the SYSCLK constant.  
//  
// INITIALIZATION PROCEDURE:  
// 1) Define SYSCLK according to external crystal frequency.  
// 2) Define desired BAUD_RATE.  
// 3) Call SW_UART_INIT().  
// 4) Set SREN to enable SW_UART receiver.  
// 5) Set SES only if user-level interrupt support is desired.  
// 6) Call SW_UART_ENABLE().  
//  
// TO TRANSMIT:  
// 1) Poll STXBSY for zero.  
// 2) Write data to TDR.  
// 3) Set CCF1 to initiate transmit.  
// 4) STI will be set upon transmit completion. An IE7 interrupt is generated if  
// user-level interrupts are enabled.  
//  
// TO RECEIVE:  
// 1) If in polled mode, poll SRI. If in interrupt mode, check SRI in IE7 Interrupt  
// Service Routine.  
// 2) Read data from RDR.  
//  
// Test code is included, for both polled and interrupt mode. Test code assumes  
// the HW_UART pins and SW_UART pins are connected externally:  
// P0.0 (HW_UART TX) -> P0.3 (SW_UART RX)  
// P0.1 (HW_UART RX) -> P0.2 (SW_UART TX)  
//  
// To use the test code in polled mode, comment out the call to the INTERRUPT_TEST()  
// at the bottom of the main routine, and uncomment the call to POLLED_TEST(). To  
// test the interrupt mode, comment out the POLLED_TEST() call and uncomment the  
// INTERRUPT_TEST() call.  
//  
// The test routines configure the HW_UART to operate with Timer 1 as the baud rate  
// source. The Timer 1 preload values are auto-calculated from the SYSCLK and BAUD_RATE  
// constants.  
//  
//-----  
// Includes  
//-----  
#include <c8051f000.h> // SFR declarations
```



## AN015 - Software UART Examples

```
//-----  
// Global CONSTANTS  
//-----  
  
#define BAUD_RATE 57600 // User-definable SW_UART baud rate  
#define SYSCLK 18432000 // System clock derived from  
// 18.432MHz XTL  
  
#define TIME_COUNT SYSCLK/BAUD_RATE/4 // Number of PCA counts for one  
// bit-time. (PCA configured to count  
// SYSCLK/4)  
  
#define TH_TIME_COUNT TIME_COUNT*3/2 // 3/2 bit-time, for use after receiving  
// a START bit. RX should be LOW for one  
// bit-time after the edge of the START,  
// and the first bit sample starts in  
// the middle of the next bit-time.  
  
#define HW_TIME_COUNT SYSCLK/BAUD_RATE/16 // Time count for HW_UART baud rate  
// generation. Auto-calculated from the  
// SYSCLK and BAUD_RATE constants  
// defined above.  
  
//-----  
//Global VARIABLES  
//-----  
  
bit SRI; // SW_UART Receive Complete Indicator  
bit STI; // SW_UART Transmit Complete Indicator  
bit STXBSY; // SW_UART TX Busy flag  
bit SREN; // SW_UART RX Enable  
bit SES; // SW_UART User-level Interrupt  
// Support Enable  
  
sbit SW_RX = P0^2; // SW_UART Receive pin  
sbit SW_TX = P0^3; // SW_UART Transmit pin  
  
char TDR; // SW_UART TX Data Register  
char RDR; // SW_UART RX Data Register (latch)  
  
// Test Variables  
char k, m; // Test indices.  
char idata SW_BUF[20]; // SW_UART test receive buffer.  
  
bit HW_DONE; // HW transfer complete flag  
// (15 characters transmitted.)  
bit SW_DONE; // SW transfer complete flag  
// (15 characters transmitted.)  
  
//-----  
// Function PROTOTYPES  
//-----  
  
void SW_UART_INIT(); // SW_UART initialization routine  
void SW_UART_ENABLE(); // SW_UART enable routine  
void PCA_ISR(); // SW_UART interrupt service routine  
void INTERRUPT_TEST(void); // SW_UART test routine (interrupt mode)
```

## AN015 - Software UART Examples



```
void POLLED_TEST(void); // SW_UART test routine (polled mode)
void USER_ISR(void); // SW_UART test interrupt service
// routine
void HW_UART_INIT(void); // HW_UART initialization and setup
// routine
void HW_UART_ISR(void); // HW_UART interrupt service routine

//-----
// MAIN Routine
//-----
// - Disables Watchdog Timer
// - Configures external crystal; switches SYSCLK to external crystal when stable.
// - Configures crossbar and ports.
// - Initializes and enables SW_UART.
// - Calls Test Routines.
//
void MAIN (void){
    int delay; // Delay counter.

    OSCXCN = 0x66; // Enable external crystal
    WDTCN = 0xDE; // disable watchdog timer
    WDTCN = 0xAD;

    // Port Setup
    XBR0 = 0x0C; // HW_UART routed to pins P0.0 and P0.1;
    // CEX0 routed to pin P0.2.
    XBR2 = 0x40; // Enable crossbar, pull-ups enabled.

    PRT0CF = 0x09; // P0.0 (HW TX), and P0.3 (SW TX)
    // configured for push-pull output.

    delay=256; // Delay >1 ms before polling XTLVLD.
    while(delay--);

    while (!(OSCXCN & 0x80)); // Wait until external crystal has
    // started.
    OSCICN = 0x0C; // Switch to external oscillator
    OSCICN = 0x88; // Disable internal oscillator; enable
    // missing clock detector.

    POLLED_TEST(); // Call Polled mode SW_UART test
    // routine.
    // INTERRUPT_TEST(); // Call Interrupt mode SW_UART test
    // routine.

    while(1); // Spin forever
}

//-----
// Functions
//-----

//-----
// INTERRUPT_TEST: SW_UART Interrupt Mode Test
// Test code to transmit and receive 15 characters to/from the HW_UART (in interrupt
// mode), with SW_UART in interrupt mode.
```



## AN015 - Software UART Examples

```
// - Initializes and enables the SW_UART & HW_UART
// - Clears all test variables & counters
// - Transfers 15 characters from HW to SW_UART, and 15 characters from SW to HW_UART,
//   simultaneously.
//
void INTERRUPT_TEST(void){

    SW_UART_INIT();                // Initialize SW_UART
    SW_UART_ENABLE();             // Enable SW_UART
    SREN = 1;                     // Enable SW_UART Receiver
    SES = 1;                      // User-level interrupt support enabled.

    HW_UART_INIT();              // Configure HW_UART for testing
                                // routine.
    k=m=0;                       // Clear user ISR counters.

    HW_DONE=0;                   // Clear transfer complete indicators
    SW_DONE=0;                   //

    IE |= 0x10;                 // Enable HW_UART interrupts
    STI = 1;                    // Indicate transmit complete to
                                // initiate first transfer.

    EIE2 |= 0x20;               // Start SW_TX by enabling
    PRT1IF |= 0x80;             // and forcing an IE7 interrupt

    TI = 1;                     // Initiate a HW_UART transmit
                                // by forcing TX interrupt.
    while(!(HW_DONE&SW_DONE));  // Wait for transfers to finish.
}

//-----
// POLLED_TEST: SW_UART Polled Mode Test
// Test code to transmit and receive 15 characters to/from the HW_UART, with SW_UART
// in polled mode.
// - Initializes and enables the SW_UART & HW_UART
// - Clears all test variables & counters
// - Sends 15 characters from the HW_UART to be received by SW_UART.
// - Sends 15 characters from the SW_UART to be received by the HW_UART.
//
void POLLED_TEST(void){

    SW_UART_INIT();                // Initialize SW_UART
    SW_UART_ENABLE();             // Enable SW_UART
    SREN = 1;                     // Enable SW_UART Receiver
    SES = 0;                      // Disable user-level interrupt support.

    HW_UART_INIT();              // Configure HW_UART for testing
                                // routine.
    k=m=0;                       // Clear test counter variables.
    HW_DONE = 0;                 // Clear transfer complete indicators
    SW_DONE = 0;                 //
    IE |= 0x10;                 // Enable HW_UART interrupts.

    TI = 1;                     // Initiate a HW_UART transmit
                                // by forcing TX interrupt.
```

## AN015 - Software UART Examples



```
// Receive 15 characters with SW_UART; transmit with HW_UART.
while(SREN) {
    if (SRI) {
        SR = 0;
        SW_BUF[k++] = RDR;
        if (k==15)
            SREN = 0;
    }
}

// Transmit 15 characters with SW_UART; receive with HW_UART.
while(STXBSY);
STXBSY = 1;
TDR=m++;
CCF1=1;

while(!SW_DONE){

    if (STI){
        STI = 0;
        if (m<16){
            STXBSY = 1;
            TDR = m++;
            CCF1 = 1;
        }
        else
            SW_DONE=1;
    }
}

//-----
// HW_UART_INIT: HW_UART Initialization Routine
// Sets up HW_UART for use in SW_UART testing.
// - HW_UART in Mode 1
// - Timer 1 used as baud rate source, clocked by SYSCLK.
//
void HW_UART_INIT(void) {

    PCON |= 0x80;
    TMOD = 0x20;
    CKCON |= 0x10;
    TH1 = -HW_TIME_COUNT;
    TL1 = -HW_TIME_COUNT;

    TR1 = 1;

    RI=0;
    TI=0;

    SCON = 0x50;

    // SMOD=1 (HW_UART uses Timer 1 overflow
    // with no divide down).

    // Configure Timer 1 for use by HW_UART
    // Timer 1 derived from SYSCLK
    // Timer 1 initial value
    // Timer 1 reload value

    // Start Timer 1

    // Clear HW_UART receive and transmit
    // complete indicators.

    // Configure HW_UART for Mode 1,
    // receiver enabled.
```



```
}
//-----
// SW_UART_INIT: SW_UART initialization routine
// Prepares SW_UART for use.
// - Configures PCA: Module 0 in negative capture mode; module 1 in software
//   timer mode; PCA time base = SYSCLK/4; PCA interrupt disabled; PCA counter
//   disabled.
// - Clears pending PCA module 0 and 1 interrupts
// - Resets TX and RX state variables
//
void SW_UART_INIT(void) {

    PCA0CPM0 = 0x10;                // Module 0 in negative capture mode;
                                   // module 0 interrupt disabled.

    PCA0CPM1 = 0x48;                // Module 1 in software timer mode;
                                   // module 1 interrupt disabled.

    PCA0CN = 0;                    // Leave PCA disabled
    PCA0MD = 0x02;                 // PCA timebase = SYSCLK/4; PCA counter
                                   // interrupt disabled.

    CCF0 = 0;                      // Clear pending PCA module 0 and
    CCF1 = 0;                      // module 1 capture/compare interrupts.

    SRI = 0;                       // Clear Receive complete flag.
    STI = 0;                       // Clear Transmit complete flag.

    SW_TX = 1;                     // TX line initially high.
    STXBSY = 0;                   // Clear SW_UART Busy flag

}

//-----
// SW_UART_ENABLE: SW_UART Enable Routine
// Enables SW_UART for use.
// - Enables PCA module 0 interrupts
// - Enables PCA module 1 interrupts
// - Starts PCA counter.
//
void SW_UART_ENABLE(void) {

    PCA0CPM0 |= 0x01;              // Enable module 0 (receive) interrupts.
    PCA0CPM1 |= 0x01;              // Enable module 1 (transmit)
                                   // interrupts.

    CR = 1;                       // Start PCA counter.
    EIE1 |= 0x08;                 // Enable PCA interrupts
    EA = 1;                       // Globally enable interrupts

}

//-----
// Interrupt Service Routines
//-----
//
// PCA_ISR: PCA Interrupt Service Routine.
```

## AN015 - Software UART Examples



```
// This ISR is triggered by both transmit and receive functions, for each bit that
// is transmitted or received.
// - Checks module 0 interrupt flag (CCF0); if set, services receive state.
// - Checks module 1 interrupt flag (CCF1); if set, services transmit state.
//
void PCA_ISR(void) interrupt 9 {

    static char SUTXST = 0;           // SW_UART TX state variable
    static char SURXST = 0;          // SW_UART RX state variable
    static unsigned char RXSHIFT;    // SW_UART RX Shift Register

    unsigned int PCA_TEMP;           // Temporary storage variable for
                                     // manipulating PCA module
                                     // high & low bytes.

    // Check receive interrupt flag first; service if CCF0 is set.
    if (CCF0){
        CCF0 = 0;                    // Clear interrupt flag.
        switch (SURXST){

            // State 0: START bit received.
            // In this state, a negative edge on SW_TX has caused the interrupt,
            // meaning a START has been detected and the PCA0CP0 registers have
            // captured the value of PCA0.
            // - Check for receive enable and good START bit
            // - Switch PCA module 0 to software timer mode
            // - Add 3/2 bit time to module 0 capture registers to sample LSB.
            // - Increment RX state variable.
            case 0:
                if (SREN & ~SW_RX){  // Check for receive enable and a good
                                     // START bit.

                    PCA_TEMP = (PCA0CPH0 << 8); // Read module 0 contents into
                    PCA_TEMP |= PCA0CPL0;       // PCA_TEMP.

                    PCA_TEMP += TH_TIME_COUNT;  // Add 3/2 bit times to PCA_TEMP

                    PCA0CPL0 = PCA_TEMP;       // Restore PCA0CPL0 and PCA0CPH0
                    PCA0CPH0 = (PCA_TEMP >> 8); // with the updated value

                    PCA0CPM0 = 0x49;          // Change module 0 to software
                                               // timer mode, interrupts enabled.

                    SURXST++;                // Update RX state variable.
                }
                break;

            // States 1-8: Bit Received
            // - Sample SW_RX pin
            // - Shift new bit into RXSHIFT
            // - Add 1 bit time to module 0 capture registers
            // - Increment RX state variable
            case 1:
            case 2:
            case 3:
            case 4:
            case 5:
```



```
case 6:
case 7:
case 8:

    RXSHIFT = RXSHIFT >> 1;           // Shift right 1 bit
    if (SW_RX)                         // If SW_RX=1,
        RXSHIFT |= 0x80;             // shift '1' into RXSHIFT MSB

    PCA_TEMP = (PCA0CPH0 << 8);       // Read module 0 contents into
    PCA_TEMP |= PCA0CPL0;             // PCA_TEMP.

    PCA_TEMP += TIME_COUNT;           // Add 1 bit time to PCA_TEMP

    PCA0CPL0 = PCA_TEMP;              // Restore PCA0CPL0 and PCA0CPH0
    PCA0CPH0 = (PCA_TEMP >> 8);      // with the updated value

    SURXST++;                          // Update RX state variable.
    break;

// State 9: 8-bits received, Capture STOP bit.
// - Move RXSHIFT into RDR.
// - Set SRI (indicate receive complete).
// - Prepare module 0 for next transfer.
// - Reset RX state variable.
// - Trigger IE7 if user-level interrupt support is enabled.
case 9:

    RDR = RXSHIFT;                    // Move received data to receive
                                        // register.
    SRI = 1;                          // Set receive complete indicator.

    PCA0CPM0 = 0x11;                  // Switch module 0 to negative capture
                                        // mode; interrupt enabled for START
                                        // detection.

    SURXST = 0;                       // Reset RX state variable.

    if (SES){                          // If user-level interrupt support
                                        // enabled
        EIE2 |= 0x20;                 // Enable IE7.
        PRT1IF |= 0x80;               // Trigger IE7.
    }
    break;
}

// Check Transmit interrupt; service if CCF1 is set.
else if (CCF1){
    CCF1 = 0;                          // Clear interrupt flag
    switch (SUTXST){

        // State 0: Transmit Initiated.
        // Here, the user has loaded a byte to transmit into TDR, and set the
        // module 1 interrupt to initiate the transfer.
        // - Transmit START bit (drop SW_TX)
        // - Read PCA0, add one bit time, & store in module 1 capture registers
```



```
// for first bit.
// - Increment TX state variable.
case 0:

    SW_TX = 0; // Drop TX pin as START bit.

    PCA_TEMP = PCA0L; // Read PCA counter value into
    PCA_TEMP |= (PCA0H << 8); // PCA_TEMP.

    PCA_TEMP += TIME_COUNT; // Add 1 bit time.

    PCA0CPL1 = PCA_TEMP; // Store updated match value into
    PCA0CPH1 = (PCA_TEMP >> 8); // module 1 capture/compare registers.

    PCA0CPM1 |= 0x48; // Enable module 1 software timer.

    SUTXST++; // Update TX state variable.
    break;

// States 1-9: Transmit Bit.
// - Output LSB of TDR onto TX
// - Shift TDR 1 bit right.
// - Shift a '1' into MSB of TDR for STOP bit in State 9.
// - Add 1 bit time to module 1 capture register
case 1:
case 2:
case 3:
case 4:
case 5:
case 6:
case 7:
case 8:
case 9:

    SW_TX = (TDR & 0x01); // Output LSB of TDR onto SW_TX pin.
    TDR >>= 1; // Shift TDR right 1 bit.
    TDR |= 0x80; // Shift '1' into MSB of TDR for
                // STOP bit in State 9.

    PCA_TEMP = (PCA0CPH1 << 8); // Read module 1 contents into
    PCA_TEMP |= PCA0CPL1; // PCA_TEMP.

    PCA_TEMP += TIME_COUNT; // Add 1 bit time to PCA_TEMP

    PCA0CPL1 = PCA_TEMP; // Restore PCA0CPL1 and PCA0CPH1
    PCA0CPH1 = (PCA_TEMP >> 8); // with the updated value

    SUTXST++; // Update TX state variable.
    break;

// State 10: Last bit has been transmitted. Transmit STOP bit
// and end transfer.
// - Transmit STOP bit
// - Set TX Complete indicator, clear Busy flag
// - Reset TX state
// - Prepare module 1 for next transfer.
// - Trigger IE7 interrupt if user-level interrupts enabled.
```



## AN015 - Software UART Examples

```
case 10:

    STI = 1;                // Indicate TX complete.
    SUTXST = 0;            // Reset TX state.
    SW_TX = 1;             // SW_TX should remain high.

    PCA0CPM1 = 0x01;       // Disable module 1 software timer;
                           // leave interrupt enabled for next
                           // transmit.

    if (SES){              // If user-level interrupt support
                           // enabled:
        EIE2 |= 0x20;      // Enable IE7.
        PRT1IF |= 0x80;    // Trigger IE7.
    }
    STXBSY = 0;           // SW_UART TX free.
    break;
}
}

//-----
// USER_ISR: User SW_UART Interrupt Service Routine (IE7 ISR)
// If interrupt-mode test code is enabled, this ISR
// transmits 15 characters and receives 15 characters. This routine is triggered each
// time a SW_UART transmit or receive is completed.
// - Checks receive complete indicator, and services.
// - Checks transmit complete indicator, and services.
// - Checks for transmits or receives that completed during the ISR; if so, triggers the
// interrupt again.
//
void USER_ISR(void) interrupt 19 { // IE7 Interrupt Service Routine

    PRT1IF &= ~(0x80); // Clear IE7 interrupt flag

    if (SRI){ // If Receive Complete:
        SRI = 0; // Clear receive flag.
        SW_BUF[k++] = RDR; // Read receive buffer.
        if (k==15){ // If 15 characters have been received:
            SREN=0; // Disable SW_UART Receiver.
        } // Indicate 15 characters received.
    }

    else if (STI){ // If Transmit Complete:
        STI = 0; // Clear transmit flag.

        if (m<15){ // If less than 15 characters:
            STXBSY = 1; // Claim SW_UART Transmitter.
            TDR = m++; // Increment variable, transmit.
            CCF1 = 1; // Force module 1 interrupt to initiate
        } // TX

    else
        SW_DONE=1; // Indicate last character transmitted.
    }
    if (STI|SRI) // If SRI or STI is set, re-trigger
        PRT1IF |= 0x80; // interrupt to service.
}
```

## AN015 - Software UART Examples

---



```
}

//-----
// HW_UART_ISR: Hardware UART Interrupt Service Routine
// Transmits characters from 1 to 15, and receives 15 characters.
// - Checks receive interrupt, and services.
// - Checks transmit interrupt, and services.
//
void HW_UART_ISR(void) interrupt 4 {

    static char i=0;                // Transmit data variable.
    static char j=0;                // Receive data index.
    static idata char HW_BUF[20];   // Receive data buffer.

    if (RI){                        // If Receive Complete:

        RI=0;                       // Clear receive flag
        HW_BUF[j++] = SBUF;         // Read receive buffer
        if (j==15)                 // If 15 characters received:
            REN=0;                 // Disable HW_UART receiver.
    }

    else if (TI){                  // If Transmit Complete:

        TI = 0;                    // Clear transmit flag
        if (i<15)                  // If characters left to transmit:
            SBUF=i++;              // Increment variable, transmit.
        else                        // If 15 characters transmitted,
            HW_DONE=1;             // Indicate HW TX finished.
    }
}

// End of Example 1, Software UART with PCA
```



## AN015 - Software UART Examples

```
-----  
; CYGNAL INTEGRATED PRODUCTS, INC.  
;  
;  
; FILE NAME      : AN015_2.ASM  
; TARGET MCU     : C8051F0xx  
; DESCRIPTION    : Example source code for a software UART  
;  
; IMPLEMENTATION NOTES:  
; - uses Timer0 in Mode3 (two 8-bit timers)  
; - Timer0 run/overflow is used for RX state machine  
; - Timer1 overflow is used for TX state machine  
; - 8N1, no Framing error detection  
; - uses IE7 as user-level interrupt  
; - uses single-byte PC offset for state table implementation  
; - uses /INT0 falling as START bit detect (primitive START bit verification)  
;  
-----  
;  
; EQUATES  
-----  
  
$MOD8F000  
  
; SW UART constants  
SW_TX_GPIO EQU P0.4 ; SW UART TX GPIO pin (can be any GPIO pin)  
SW_RX_GPIO EQU P0.2 ; SW UART RX GPIO pin (must be /INT0)  
  
TIME_COUNT EQU 320 ; Note: 320 is the limit for reliable  
; FD operation...  
; FOR SYSCLK = 18.432 MHz:  
; 115200 = 160  
; 57600 = 320  
; 38400 = 480  
; 19200 = 960  
; 9600 = 1920  
; 4800 = 3840  
; 2400 = 7680  
  
TX_CORR EQU 41 ; (41) Timer preload correction value in  
; cycles for TX  
RX_CORR EQU 47 ; (47) Timer preload correction value in  
; cycles for RX  
THALF_CORR EQU 113 ; (113) Timer preload correction value for  
; 3/2 RX  
  
TX_BT EQU TIME_COUNT - TX_CORR; actual 16-bit bit counter cycle value  
; TX  
RX_BT EQU TIME_COUNT - RX_CORR; actual 16-bit bit counter cycle value  
; RX  
THALF_BT EQU TIME_COUNT*3/2 - THALF_CORR ; actual 16-bit 1.5 bit cycle value  
; RX  
  
RX_BUFSIZE EQU 16 ; size of RX buffer in chars  
-----
```

## AN015 - Software UART Examples



```
; VARIABLES
;-----

BSEG
    org 0h

SRI:      DBIT      1          ; SW UART Receive complete flag
STI:      DBIT      1          ; SW UART Transmit complete flag
STXBSY:   DBIT      1          ; SW UART TX BSY flag
SREN:     DBIT      1          ; SW UART RX Enable
SES:      DBIT      1          ; SW UART user-Interrupt Support Enable

DSEG at 30h

TDR:      DS        1          ; SW UART TX data register
RDR:      DS        1          ; SW UART RX data register
RXSHIFT:  DS        1          ; SW UART RX shift register
SURXST:   DS        1          ; SW UART RX state variable
SUTXST:   DS        1          ; SW UART TX state variable
BCRHI:    DS        1          ; MSB of 16-bit bit timer for SW UART RX
BCTHI:    DS        1          ; MSB of 16-bit bit timer for SW UART TX

;test variables
RX_TAIL:  DS        1          ; write pointer to RX message buffer
TX_VAL:   DS        1          ; value to transmit
;-----
; Indirect address space variables

ISEG at 80h

RX_BUF:   DS          RX_BUFSIZE ; RX message buffer
;-----
; STACK

STACK_TOP: DS        1          ; placeholder in symbol table for
; beginning of hardware stack

;-----
; MACRO DEFINITIONS
;-----

;-----
; RESET AND INTERRUPT VECTOR TABLE
;-----

CSEG
    org 00h
    ljmp Reset          ; RESET initialization vector

    org 03h
    ljmp INT0_ISR       ; Software UART RX START bit detect

    org 0bh
    ljmp Timer0_ISR     ; Software UART RX state machine interrupt

    org 1bh
```



## AN015 - Software UART Examples

```
        ljmp    Timer1_ISR            ; Software UART TX state machine interrupt

        org    9bh
        ljmp    IE7_ISR              ; user-level Software UART interrupt

;-----
; MAIN PROGRAM CODE
;-----

        org    0B3h

Main:
        ajmp    PolledRX_PolledTX    ; leave one of these lines uncommented
;
        ajmp    InterruptRX_InterruptTX; leave one of these lines uncommented

        sjmp    $                    ; spin forever...

;-----
; MAIN SUBROUTINES
;-----

;-----
; PolledRX_PolledTX
;-----
; This routine demonstrates polled access to the SW UART.
;
; The transmitter transmits a sequence from $00 to $ff
;
; The receiver receives characters and stores them in a circular buffer.
;
PolledRX_PolledTX:
        acall   SW_UART_Init         ; initialize SW UART (leave in a
                                     ; disabled state)

        setb   SREN                  ; enable SW UART receiver
        clr    SES                   ; disable user-level interrupt
                                     ; support
        acall   SW_UART_Enable       ; enable SW UART

        ; transmit message -- polled mode
        jb     STXBSY, $             ; wait for SW TX available

        ; transmit chars $00 to $ff
        clr    a
TX_LOOP:  setb   STXBSY               ; claim SW UART Transmitter
        mov    TDR, a                ; write char to transmit data reg
        setb   ET1                   ; initiate SW TX operation
        inc    a                      ; set next value to write
        jnb   STI, $                 ; wait for TX complete
        clr   STI                     ; clear TX complete indicator
        jnz   TX_LOOP

TX_LOOP_END:
        mov    RX_TAIL, #RX_BUF      ; initialize TAIL pointer

; receive message -- polled mode
RX_LOOP:  mov    r0, RX_TAIL         ; indirect address to write character to
```

## AN015 - Software UART Examples



```

        jnb    SRI, $                ; wait for RX character
        clr    SRI                    ; clear RX complete indicator
        mov    @r0, RDR               ; store it
        inc    RX_TAIL                ; advance TAIL pointer
        mov    a, RX_TAIL             ; handle TAIL wrapping
        add    a, #-(RX_BUF + RX_BUFSIZE)
        jnc    RX_LOOP
        mov    RX_TAIL, #RX_BUF      ; wrap TAIL

        sjmp   RX_LOOP                ; repeat forever...

;-----
; InterruptRX_InterruptTX
;-----
; This routine demonstrates interrupt access to the SW UART.
;
; The receiver receives characters and stores them in a circular buffer.
; Both the transmit and receive routines are located in the IE7_ISR handler.
;
InterruptRX_InterruptTX:

        acall  SW_UART_Init          ; initialize SW UART (leave in a
        ; disabled state)
        setb   SES                    ; Enable user-level interrupt support
        setb   SREN                   ; Enable SW UART receiver

        mov    RX_TAIL, #RX_BUF      ; initialize TAIL pointer

        acall  SW_UART_Enable        ; enable SW UART

        setb   STI                    ; kick-start SW UART transmitter
        orl    EIE2, #00100000b      ; by enabling IE7
        orl    PRT1IF, #10000000b    ; and activating IE7

        sjmp   $

;-----
; INTERRUPT VECTORS
;-----
;-----
; Reset Interrupt Vector
;
; This routine initializes the device and all peripherals and variables.
; - External oscillator started (SYSCLK will be switched to external osc.
;   once XTLVLD goes high)
; - Watchdog timer is disabled
; - Crossbar and GPIO output modes are defined
; - H/W stack pointer is initialized
; - interrupt priorities and enables are initialized here
; - /INT0
; - Timer0
; - Timer1

Reset:

        mov    OSCXCN, #01100110b    ; Enable Crystal osc., divide by 1 mode
        ; XFCN = '110' for 18.432 MHz crystal
```



## AN015 - Software UART Examples

```
                                ; External oscillator will be selected
                                ; below after XTLVLD has gone high
                                ; indicating that the external osc
                                ; has started and settled (several
                                ; hundred microseconds from now).

mov    WDTCN, #0deh             ; disable watchdog timer
mov    WDTCN, #0adh

; set up Crossbar and Port I/O
mov    XBR0, #00000100b        ; enable HW UART on P0.0 (TX), P0.1 (RX)
mov    XBR1, #10000100b        ; enable /INT0 on P0.2; /SYSCLK on P0.3
mov    XBR2, #01000000b        ; enable crossbar w/ pull-ups enabled
orl    PRT0CF, #00011101b      ; enable P0.0, 0.2, 0.3, and 0.4 as push-pull
                                ; P0.4 is SW UART TX pin
                                ; P0.2 is SW UART RX pin
orl    PRT1CF, #01000000b      ; enable P1.6 (LED on target board) as
                                ; push-pull

mov    SP, #STACK_TOP         ; init stack pointer to end of allocated RAM

; Wait >1 ms before checking external crystal for stability
clr    a
mov    r0, a                   ; Clear r0

djnz   r0, $                   ; Delay ~380 µs
djnz   r0, $                   ; Delay ~380 µs
djnz   r0, $                   ; Delay ~380 µs

OSC_WAIT:
mov    a, OSCXCN               ; spin here until crystal osc is stable
jnb    acc.7, OSC_WAIT

orl    OSCICN, #00001000b      ; Select external osc. as
                                ; system clock source
andl   OSCICN, #NOT(00000100b); Disable internal oscillator
orl    OSCICN, #10000000b      ; Enable missing clock detector
                                ; this must be done AFTER
                                ; selecting external osc as system
                                ; clock source

setb   EA                     ; enable GLOBAL interrupts

ljmp   Main

;-----
; Timer0_ISR / INTO_ISR
;
; These interrupts start and drive the SW UART receive state machine
;
SWRX_STATE_TABLE:              ; each table entry is 1 byte
    DB    SWRX_S0 - SWRX_STATE_TABLE ; IDLE / START detect
    DB    SWRX_S1 - SWRX_STATE_TABLE ; b0
    DB    SWRX_S2 - SWRX_STATE_TABLE ; b1
    DB    SWRX_S3 - SWRX_STATE_TABLE ; b2
    DB    SWRX_S4 - SWRX_STATE_TABLE ; b3
    DB    SWRX_S5 - SWRX_STATE_TABLE ; b4
```

## AN015 - Software UART Examples



```
DB      SWRX_S6 - SWRX_STATE_TABLE ; b5
DB      SWRX_S7 - SWRX_STATE_TABLE ; b6
DB      SWRX_S8 - SWRX_STATE_TABLE ; b7
DB      SWRX_S9 - SWRX_STATE_TABLE ; STOP bit capture

INT0_ISR:
Timer0_ISR:
    push    PSW                ; resource preservation
    push    acc

    mov     a, BCRHI           ; if BCRHI is non-zero, we need to roll
                                ; through the timer again...

    jz     SWRX_PROCESS_STATE
    dec    BCRHI
    ajmp   Timer0_ISR_EXIT

SWRX_PROCESS_STATE:
    push    DPH                ; resource preservation
    push    DPL

    mov     a, SURXST          ; read state offset from table
    mov     DPTR, #SWRX_STATE_TABLE
    movc   a, @A+DPTR          ; 'a' now contains state offset (PC)
    jmp    @A+DPTR             ; execute state

Timer0_ISR_END:                ; ALL RX states return here

    pop     DPL                ; resource restoration
    pop     DPH

Timer0_ISR_EXIT:
    pop     acc                ; resource restoration
    pop     PSW
    reti

;SWRX_S0: RX IDLE state
; At this point, a falling edge has been detected on /INT0.
; We first check to see if the SW UART receiver is enabled.  If it is, we check
; once to see if the RX pin is still low (START bit valid).  If it is, we set up
; Timer0 to count for 3/2 bit time in order to capture the LSB.  Here, we also
; disable /INT0 interrupts.
; - Check for SREN = '1':  IF '1':
;     - Load TL0 with 3/2 bit time value
;     - Start Timer
;     - Enable TF0 interrupt
;     - Disable /INT0 interrupt
;     - INC state variable to S1
; - IF SREN = '0' (SW UART RX disabled)
;     - exit gracefully, next state is S0
;

SWRX_S0:
    jnb    SREN, SWRX_S0_END    ; Check to see if SW UART RX is enabled
                                ; if not, exit and remain at IDLE state

    jb     SW_RX_GPIO, SWRX_S0_END; check to see if START bit is good

    clr    EX0                 ; disable /INT0
```



## AN015 - Software UART Examples

```
clr    TR0                ; Stop Timer0 (low)
clr    TF0                ; Clear any pending interrupts

mov    BCRHI, #HIGH(THALF_BT); set Timer0 (low) + BCRHI for 1.5 bit
mov    TL0, #-LOW(THALF_BT); times from now (we assume the start
                                ; bit is good)

setb   ET0                ; enable Timer0 interrupts
setb   TR0                ; Start Timer0L

inc    SURXST             ; next state is SWRX_S1 (we assume START bit
                                ; is good)

SWRX_S0_END:
    ajmp Timer0_ISR_END

;SWRX_S1 thru SWRX_S8: Capture b0..b7
; At this point, we've determined that the START bit is valid, and we're going to
; query RX_GPIO at bit intervals, shifting the results into RXSHIFT.
; - If BCRHI is non-zero, then we need to spin through the timer again
;     - DEC BCRHI
;     - let timer roll over on its own
;     - leave state as is
; - If BCRHI is zero:
;     - stop timer
;     - Move RX_GPIO state into Carry
;     - Right shift Carry into RXSHIFT
;     - set up timer to capture the next bit
;     - enable timer
;     - advance state variable
;
SWRX_S1:
SWRX_S2:
SWRX_S3:
SWRX_S4:
SWRX_S5:
SWRX_S6:
SWRX_S7:
SWRX_S8:

clr    TR0                ; Stop Timer0 (low)
clr    TF0                ; Clear any pending interrupts

mov    BCRHI, #HIGH(RX_BT) ; load bit time value into 16-bit virtual
                                ; counter
mov    TL0, #-LOW(RX_BT)

setb   TR0                ; START RX bit timer

mov    C, SW_RX_GPIO      ; Move RX state into Carry prior to rshift

mov    a, RXSHIFT
rrc    a                  ; right shift Carry into shift register
mov    RXSHIFT, a        ; re-store

inc    SURXST             ; advance state variable

SWRX_S2_END:
```

## AN015 - Software UART Examples



```
        ajmp    Timer0_ISR_END

;SWRX_S9: Capture STOP bit
; At this point, we've shifted all the data bits into RXSHIFT, and we're ready to
; sample the STOP bit. Here, we indicate that we've received a character, and reset
; the state machine back to IDLE. In this implementation, we don't actually capture
; the STOP bit; we assume it's good. Here's where we would add support for Framing
; Error detection.
; - If BCRHI is non-zero, then we need to spin through the timer again
;     - DEC BCRHI
;     - let timer roll over on its own
;     - leave state as is
; - If BCRHI is zero:
;     - stop timer
;     - Move RXSHIFT into RDR
;     - Set SRI
;     - Disable timer interrupt
;     - Enable /INT0 interrupt
;     - Reset state variable to IDLE
;     - Check to see if User-level interrupt support is enabled (EIS): If so:
;         - Enable IE7
;         - Toggle P1.7 to activate IE7
;
SWRX_S9:
        clr    TR0                ; Stop Timer0L
        mov    RDR, RXSHIFT      ; move data from shift reg to data reg

        setb   SRI                ; set SW UART SRI bit to indicate RX complete
        clr    ET0                ; Disable Timer0L interrupt
        clr    IE0                ; Disable pending /INT0 interrupts
        setb   EX0                ; Enable /INT0 interrupt
        mov    SURXST, #00        ; reset RX state to IDLE

        jnb    SES, SWRX_S9_END   ; check to see if user-level interrupt
                                   ; support is enabled
        orl    EIE2, #00100000b   ; enable IE7; leave priority alone
        orl    PRT1IF, #10000000b ; activate IE7

SWRX_S9_END:
        ajmp    Timer0_ISR_END

;-----
; Timer1_ISR (note that this is actually called by the upper-half of Timer0
; which is operating in Mode 3)
;
; This interrupt drives the SW UART transmit state machine
;

SWTX_STATE_TABLE:                ; each table entry is 1 byte; 11 entries
                                   ; total
        DB     SWTX_S0 - SWTX_STATE_TABLE; START bit
        DB     SWTX_S1 - SWTX_STATE_TABLE; b0
        DB     SWTX_S2 - SWTX_STATE_TABLE; b1
        DB     SWTX_S3 - SWTX_STATE_TABLE; b2
        DB     SWTX_S4 - SWTX_STATE_TABLE; b3
        DB     SWTX_S5 - SWTX_STATE_TABLE; b4
        DB     SWTX_S6 - SWTX_STATE_TABLE; b5
        DB     SWTX_S7 - SWTX_STATE_TABLE; b6
```



## AN015 - Software UART Examples

```
DB      SWTX_S8  - SWTX_STATE_TABLE; b7
DB      SWTX_S9  - SWTX_STATE_TABLE; STOP bit onset edge
DB      SWTX_S10 - SWTX_STATE_TABLE; STOP bit terminus

Timer1_ISR:
    push    PSW                ; resource preservation
    push    acc

    mov     a, BCTHI           ; if BCTHI is non-zero, we need to roll
                                ; through the timer again...
    jz     SWTX_PROCESS_STATE
    dec    BCTHI
    ajmp   Timer1_ISR_EXIT

SWTX_PROCESS_STATE:
    push    DPH                ; resource preservation
    push    DPL

    mov     a, SUTXST          ; read state offset from table
    mov     DPTR, #SWTX_STATE_TABLE
    movc   a, @A+DPTR          ; acc now contains state offset
    jmp    @A+DPTR             ; execute State x

Timer1_ISR_END:                ; ALL TX states return here

    pop     DPL                ; resource restoration
    pop     DPH

Timer1_ISR_EXIT:
    pop     acc                ; resource restoration
    pop     PSW

    reti

;SWTX_S0: TX START bit state
; At this point, user code has placed the char to be transmitted in TDR and has
; called the Timer1 interrupt handler explicitly by setting TF1.
; - Clear STI
; - Drop TX_GPIO (START bit onset edge)
; - Configure TH0, BCTHI for next bit time, which will be the LSB
; - Enable TH0
; - Set next state to SWTX_S1
;
SWTX_S0:
    mov     BCTHI, #HIGH(TX_BT) ; load bit time value into 16-bit virtual
                                ; counter
    mov     TH0, #-LOW(TX_BT)
    clr    SW_TX_GPIO          ; START bit onset edge
    clr    TF1                 ; clear any pending interrupts

    inc    SUTXST              ; next state is SWTX_S1
SWTX_S0_END:
    ajmp   Timer1_ISR_END

;SWTX_S1 thru SWTX_S9: TX b0..b7 and STOP bit
; At this point, we start shifting the character in TDR out the TX_GPIO pin, bit
; by bit, one bit per state transition. We shift in an extra '1' at the MSB which
; becomes the STOP bit.
```



## AN015 - Software UART Examples

---

```
; - If BCTHI is non-zero, then we need to spin through the timer again
;         - DEC BCTHI
;         - let timer roll over on its own
;         - leave state as is
; - If BCTHI is zero:
;         - stop timer
;         - set up timer for next bit
;         - right-shift TDR
;         - enable timer
;         - output bit
;         - advance state variable
;
SWTX_S1:
SWTX_S2:
SWTX_S3:
SWTX_S4:
SWTX_S5:
SWTX_S6:
SWTX_S7:
SWTX_S8:
SWTX_S9:
        mov     BCTHI, #HIGH(TX_BT) ; load bit time value into 16-bit virtual
                                           ; counter
        mov     TH0, #-LOW(TX_BT)

        mov     a, TDR                 ; right shift next bit to transmit into Carry
        setb    C                       ; shift STOP bit into MSB
        rrc     a
        mov     TDR, a                 ; re-store value
        mov     SW_TX_GPIO, C          ; output bit on GPIO pin
        clr     TF1                    ; clear any pending interrupts

        inc     SUTXST                 ; advance to next state

SWTX_S1_END:
        ajmp    Timer1_ISR_END

;SWTX_S10 STOP bit complete / reset to IDLE
; At this point, we've shifted the STOP bit out, and we're ready to reset the state
; machine and indicate transmit complete, including initiating a user-level interrupt
; if it's enabled.
; - If BCTHI is non-zero, then we need to spin through the timer again
;         - DEC BCTHI
;         - let timer roll over on its own
;         - leave state as is
; - If BCTHI is zero:
;         - stop timer
;         - set STI
;         - clear STXBSY
;         - check for IE7 support, and activate if enabled
;         - set state variable to S0
;
SWTX_S10:
        clr     ET1                    ; Disable Timer1 interrupts
        setb    TF1                    ; Force a pending Timer1 interrupt. This
                                           ; allows the Enable Timer1 interrupt
                                           ; operation to immediately trigger a
```



## AN015 - Software UART Examples

```
                                ; transmit operation

mov    SUTXST, #00h           ; reset state variable to IDLE state
setb   STI                    ; Set STI to indicate transmit complete
clr    STXBSY                 ; Clear TXBSY to indicate transmitter
                                ; available
jnb    SES, SWTX_S10_END      ; activate user-level interrupt IE7 if
                                ; enabled
orl    EIE2, #00100000b       ; enable IE7; leave priority alone
orl    PRT1IF, #10000000b     ; activate IE7

SWTX_S10_END:
    ajmp    Timer1_ISR_END

;-----
; IE7_ISR
;
; This is the user-level interrupt handler for the SW UART. Note: this code
; MUST check both SRI and TRI, and if both are set, it must handle one case, and
; re-trigger IE7 for the other case (or handle it in the same call) if that case
; is interrupt handled. This is not required, for example, if the RX case is
; handled in the interrupt and the TX case is polled.
;
; Note, if the TX case is polled, STI should not be cleared here.
;
; In this example, if SRI is set, indicating that a character was received by
; the SW UART, that received character is stored in a circular buffer (RX_BUF).
; If STI is set, indicating transmit complete, the character stored in TX_VAL
; is transmitted (and post incremented).
;
;
IE7_ISR:
    push   PSW
    push   acc

    anl    PRT1IF, #NOT(10000000b); clear IE7
    jbc    SRI, SW_RX_HANDLE     ; handle receive first, since
                                ; it's the most sensitive to
                                ; latency
    jbc    STI, SW_TX_HANDLE     ; handle TX case
IE7_ISR_END:
    pop    acc
    pop    PSW
    reti                                ; all IE7_ISR routines return here...

SW_RX_HANDLE:
    push   ar0                    ; resource preservation

    mov    r0, RX_TAIL           ; point r0 to location to store
    mov    @r0, RDR              ; read value into buffer
    inc    RX_TAIL               ; update the TAIL pointer
    mov    a, RX_TAIL            ; wrap pointer if necessary
    add    a, #- (RX_BUF+RX_BUFSIZE)
    jnc    SW_RX_HANDLE_END
    mov    RX_TAIL, #RX_BUF      ; wrap the pointer

SW_RX_HANDLE_END:
```

## AN015 - Software UART Examples



```
        jnb     STI, NO_TX_PENDING ; if TX interrupt is pending,
        orl     PRT1IF, #10000000b ; activate it (IE7)

NO_TX_PENDING:
        pop     ar0
        ajmp    IE7_ISR_END

SW_TX_HANDLE:
        setb    STXBSY             ; claim SW UART Transmitter
        mov     TDR, TX_VAL        ; load byte to transmit into TDR
        setb    ET1                ; start SW UART transmitter
        inc     TX_VAL             ; next byte to store

SW_TX_HANDLE_END:
        jnb     SRI, NO_RX_PENDING ; if RX interrupt is pending,
        orl     PRT1IF, #10000000b ; activate it (IE7)
NO_RX_PENDING:
        ajmp    IE7_ISR_END        ; exit

;-----
; SUBROUTINES
;-----

;-----
; SW UART SUBROUTINES (non-user code)
;-----

;-----
; SW_UART_Init
;
; Init:
; - /INT0 is falling-edge triggered
; - Timer0 in Mode 3, (2) 8-bit timers, interrupt handlers for TL0, TH0 (TF0, TF1)
;   timers initially disabled...
; - RX/TX State machines and state variables
; - SW UART TX state machine and RX state machine operate at HIGH priority
SW_UART_Init:
        ; Init /INT0
        clr     EX0                ; disable /INT0 interrupts
        setb    IT0                ; /INT0 is falling-edge triggered
        clr     IE0                ; forcibly clear /INT0 interrupt flag
        setb    PX0                ; /INT0 is HIGH priority interrupt

        ; Init Timer0
        clr     ET0                ; disable Timer0 interrupts
        clr     ET1                ; disable Timer1 interrupts
        clr     TR0                ; Timer0 off
        clr     TR1                ; Timer1 off
        clr     TF0                ; forcibly clear interrupt flags
        clr     TF1
        orl     TMOD, #00000011b   ; Timer0 in Mode 3 (2) 8-bit timers
        anl     TMOD, #NOT(00001100b); GATE0=0; C/T0 = 0
        orl     CKCON, #00001000b ; Timer0 uses system clock as time base
        setb    PT0                ; Timer0 interrupt is HIGH priority
        setb    PT1                ; Timer1 interrupt is HIGH priority

        ; User-level interrupt (IE7) is initialized explicitly by the state
```



```
; machines

; Init State Machines and Variables
clr    a                ; Init state machines
mov    SURXST, a        ; RX state variable
mov    SUTXST, a        ; TX state variable
mov    BCRHI, a         ; RX bit timer MSB
mov    BCTHI, a         ; TX bit timer MSB
clr    SES              ; Disable user-level interrupt support
clr    SREN             ; Disable SW UART receiver
clr    TXBSY           ; clear TXBSY indicator
clr    SRI              ; clear RX complete indicator
clr    STI              ; clear TX complete indicator

ret

;-----
; SW_UART_Enable
;
; The SW_UART is enabled by enabling the interrupt handlers that move the transmit
; and receive state machines from their IDLE states to their corresponding next
; states. /INT0 transitions the RX state machine from IDLE to START. Timer1,
; which is called explicitly by the user code (setb TF1), transitions the
; transmit state machine from IDLE/START to TX_LSB.
;
; The user-level interrupt (IE7) is enabled in the state machines themselves
; after polling EIS (external interrupt support).
;
SW_UART_Enable:
    clr    IE0          ; clear pending /INT0 interrupts
    setb   TF1          ; Force a pending Timer1 interrupt
    setb   EX0          ; enable /INT0 interrupts
    clr    ET1          ; keep Timer1 interrupts disabled
    setb   TR1          ; Enable Timer1

    ret

;-----
; SW_UART_Disable
;
; The SW UART is disabled by disabling all of its state machine interrupts,
; including the user-level interrupt (IE7), if the status register indicates that
; it's enabled.
SW_UART_Disable:
    clr    EX0          ; disable /INT0 interrupts
    clr    ET0          ; disable Timer0 interrupts
    clr    ET1          ; disable Timer1 interrupts
    jnb   SES, SW_UART_Dis_End; check to see if IE7 use is enabled
    anl   EIE2, #NOT(00100000b); disable IE7 interrupts

SW_UART_Dis_End:
    ret

;-----
; End of file.

; End of Example 2, Software UART with Timer 0.
```

END