



---

## AN011 - Using C8051Fxxx in 5 Volt Systems

---

### Relevant Devices

This application note applies to the following devices:  
C8051Fxxx family of SoC's

---

### Introduction

The purpose of this document is to describe how to incorporate Cygnal's C8051Fxx family of devices in existing 5 volt systems.

When using a 3 volt device in a 5 volt system, the user must consider:

1. A 3 volt power supply must be provided.
2. A 5 volt device driving a 3 volt input.
3. A 3 volt device driving a 5 volt input.

### Power Supply

There are several factors in determining what method should be used to provide the 3 volt power supply from the existing 5 volt power supply. Among these is the reliability of the 5 volt power supply and the source of power to the system (i.e., battery or AC with rectifier). Conditioning the 5 volt power supply to provide 3 volts will increase the number of components in the design and will cost some additional power, which is especially important in low power applications using a battery.

### Rectified Line Power Supply

Power may be supplied from commercial commercial power supply. This supply is typically poorly regulated. To provide a "clean" stable

3 volt power supply, we use a Low Dropout Regulator (LDO).

The LDO must be able to supply the specified current for the given part and other 3 volt peripherals that may be in use in the application. These specifications may be found in the appropriate data sheets. For example, the typical current specified in Cygnal's C8051F001 Data Sheet is 12 mA @ 20 MHz with analog peripherals active (10mA digital supply current with CPU active and 2mA for analog peripherals). Additionally, if other devices are in use such as LED's, the design must account for the additional current needed.

Some example LDO's available that convert 5 volts to 3 volts are:

- National Semiconductor's LM3940 ([www.national.com](http://www.national.com))
- Texas Instrument's TPS769xx Family ([www.ti.com](http://www.ti.com))

### Battery Power Supply

Batteries generally provide a clean power supply. However, applications using batteries must be low power, so DC-DC converters should be used as they are more efficient than LDO's.



The device must be able to provide the proper voltage for the application's required maximum current. Some DC-DC converters available are:

- National Semiconductor's LM2825 ([www.national.com](http://www.national.com))
- C&D Technologies' LME305D and LME305S ([www.dc-dc.com](http://www.dc-dc.com))
- Texas Instrument's TPS769xx family of LDO's is also optimized for battery applications ([www.ti.com](http://www.ti.com))

Unlike LDO's, DC-DC converters can provide an output voltage that is higher than the input voltage.

### Driving a 3 Volt Input With a 5 Volt Output

Connecting a 5 volt driver to a standard 3 volt input can cause damage or reduce component life due to current flow into ESD protection devices. Cygnal's C8051Fxxx family of devices use input structures that are *5 volt tolerant*. Thus, the designer may connect Cygnal's 5 volt devices directly to digital input pins without causing harmful current flow.

### Driving a 5 Volt Input With a 3 Volt driver

Although the C8051Fxxx digital inputs are 5 volt tolerant, the outputs can only drive as high as VDD (2.7 to 3.6 volts). If the 5 volt device requires an input voltage higher than VDD to operate, then additional configuration is necessary.

To supply an input voltage greater than VDD, we set the Output Mode of the port pin to "open-drain" and connect the output to the 5 volt power supply via a pull-up resistor. In this way, a logic '1' output from the C8051Fxxx will rise to 5 volts, and a logic '0' will go to ground. See Figure 1 below. Note that the port pins default to open-drain configuration upon reset.

### Choosing a Pull-Up Resistor

When the port pin is a logic '0', the output voltage will be near ground. In this state, current will flow to ground through the pull-up resistor and port driver. To save power, we desire a large value resistor to minimize this current flow.

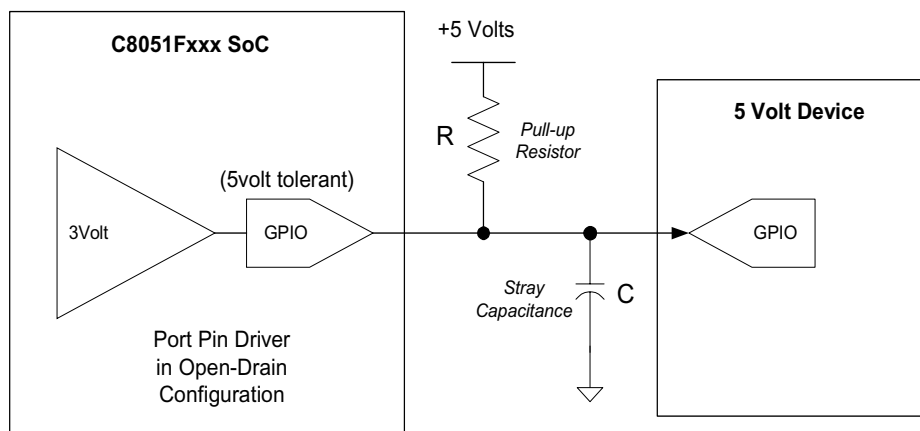

Figure 1. C8051Fxxx Device Driving 5 Volt Device Input

When the port pin is set to logic '1', the output driver turns off and the voltage at the port output is pulled high through the pull-up resistor. The rise time of this signal can be quite long and is determined by the value of the pull-up resistor and the amount of stray capacitance due to the connecting trace and input circuitry. In the circuit in Figure 1 the stray capacitance will be charged from the 5 volt power supply through the pull-up resistor with a time constant equal to the product of the stray capacitance and pull-up resistance as follows:

$$V(t) = 5 \text{ Volts} \left( 1 - e^{-\frac{t}{RC}} \right)$$

### Equation 1. Charging Stray Capacitance

This is of small consequence if timing is not important (e.g., a push button or chip select signals). However, if the timing is important (e.g., serial communications, clock signal synchronization), then the charge time must be considered, and this will limit the maximum size of the pull-up resistor. A pull-up resistor that is large will result in a large time to charge the stray capacitance, and a long time to get the port pin voltage high enough to realize a logic '1'. See Figure 2 below, where T is the time it takes to charge above the voltage required for the 5 volt device to realize a logic

'1' (commonly referred to as  $V_{ih}$ ). This voltage will depend on the application, as will the value of the stray capacitance. If the time constant is too large, the 5 volt device may never receive a high enough voltage to realize a logic '1' at a given square wave frequency. For this reason, the chosen pull-up resistance (R) must be low enough for proper input, but the R must not be so low that excessive power is dissipated in the pull-up resistor during logic low state.

Once the maximum acceptable rise time (T) is determined for a given application, the value of the pull-up resistor (R) can be calculated by solving Equation 1 for R:

$$R = \frac{T}{C \cdot \ln\left(\frac{5}{5 - V_{ih}}\right)}$$

where,  $V_{ih}$  = voltage for logic '1' and  
 $T$  = max time to reach logic '1'

### Equation 2. Calculating the Pull-Up Resistor Value (R)

Even though there is a slight delay in the output voltage dropping from high to low ('1' to '0'), this time is insignificant when compared to the rise-time. This is illustrated (although exaggerated) in Figure 2 to show the small

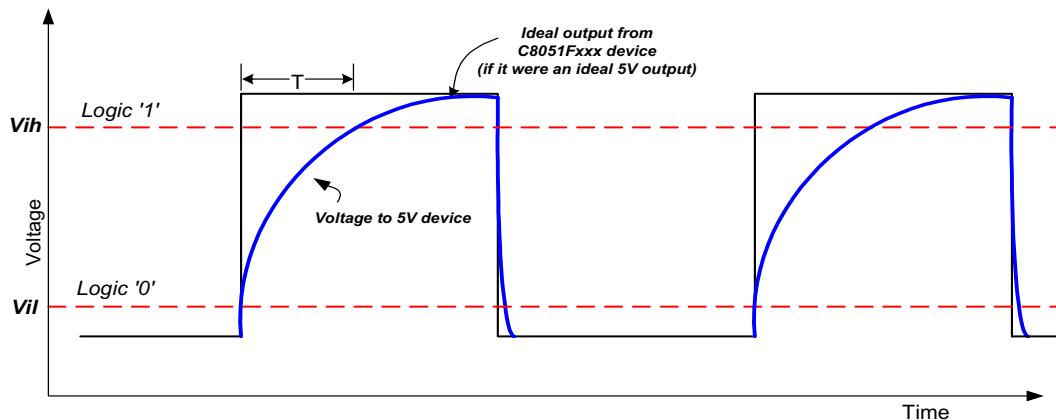

**Figure 2. Square Wave With Charge Time Due To Stray Capacitance**



decay time. The charge in the stray capacitance discharges through the C8051Fxxx port driver with a small voltage drop to ground.

As previously mentioned, if the resistance is low, large amounts of power may be consumed as current flows from the 5 volt power supply to ground in logic '0' state. Additionally, if the value of the resistor is too low, the low state voltage may be too high to realize a logic '0' ( $V_{ol}$ ) due to the voltage drop across the port driver. For example, the  $V_{ol}$  specification for the C8051F0xx devices is 0.6 volts at 8.5 mA. A small resistance may result in higher currents and thus a higher voltage input to the 5 volt device.

In summary, a pull-up resistor must be:

1. Large enough to prevent excessive current flow and power consumption in the logic '0' state.
2. Large enough keep the voltage below the  $V_{il}$  specification of the 5 volt device to realize a logic '0' state.
3. Small enough to provide acceptable rise times based on the amount of stray capacitance and the requirements of the application.

### Example

The following is an example of calculating a proper pull-up resistor value (R) for a given stray capacitance (C), required voltage level for a logic '1' ( $V_{ih}$ ), and frequency of state change to determine maximum allowable rise time (T). Additionally, we will investigate the power consumption in the pull-up resistor and voltage level in when in the logic '0' state. From this, we will determine a value for the pull-up resistor (R).

In this example application, we will consider an application using the SMBus which uses an open-drain synchronizing clock signal (SCL) output from a C8051Fxxx in Master Mode (supplying the SCL signal to other devices). This signal will output to a 5 volt device, and so the configuration in Figure 1 on page 2 will be used to ensure proper voltage supplied. Ensure port pins used in this method are configured as open-drain (see associated data sheets). C8051Fxxx port pins default to open-drain configuration upon reset.

A proper pull-up resistor value (R) must be calculated to ensure:

- Minimal current/power loss when in a logic low ('0') state (R too low).
- Performance specifications are not violated due to the rise time associated with the stray capacitance and pull-up resistance. (R too high).
- In a logic low state, voltage is not too high due to the voltage drop across the port driver (R too low).

Ideally, a high resistance would be used in order to minimize power loss which can be critical in low power applications (i.e., when using a battery power supply). We will calculate the highest resistance we can use while meeting voltage rise time specifications. For this application, the voltage should be high enough to realize a logic '1' for CMOS logic in the 5 volt device within 5% of the clock period. We assume a  $V_{ih}$  of  $0.8 \cdot V_{DD}$ , or 4 volts. Choosing a SCL frequency of 400 kHz, our voltage should rise to 4 volts within 125 ns.

Thus, referring to Equation 2,  $T = 125$  ns, and  $V_{ih} = 4$  volts. We will assume the stray capacitance to be 10 pF with one slave device connected to the SCL line. (This will vary for



different applications, depending on number of devices connected and amount of wiring and traces used to connect these devices). Using Equation 2, we calculate  $R = 7.77 \text{ k}\Omega$ . This is the maximum resistor value that can be used at the specified SCL frequency and specification we set for the CMOS input logic. Note that the SCL frequency were lower, then a higher resistance could be used.

Now that we have a desired maximum pull-up resistance, we can calculate the current flowing through the circuit when at a logic '0' to see if this is acceptable for a given application. In the worst case condition, we calculate the current flow with a 5 volt power supply and negligible voltage drop in the port pin to ground. The current through the  $7.77 \text{ k}\Omega$  resistor is then  $644 \mu\text{A}$ . The power dissipation in the pull-up resistor at  $644 \mu\text{A}$  of current is approximately  $3.2 \text{ mW}$ .