



# Precision Picoampere Input Current Quad Operational Amplifier

## OP-497

### FEATURES

- Low Offset Voltage: 50  $\mu$ V max
- Low Offset Voltage Drift: 0.5  $\mu$ V/ $^{\circ}$ C max
- Very Low Bias Current
  - +25 $^{\circ}$ C: 100 pA max
  - 55 $^{\circ}$ C to +125 $^{\circ}$ C: 450 pA max
- Very High Open-Loop Gain: 2000 V/mV min
- Low Supply Current (per Amplifier): 625  $\mu$ A max
- Operates from  $\pm$ 2 V to  $\pm$ 20 V Supplies
- High Common-Mode Rejection: 120 dB min

### APPLICATIONS

- Strain Gage and Bridge Amplifiers
- High Stability Thermocouple Amplifiers
- Instrumentation Amplifiers
- Photo-Current Monitors
- High-Gain Linearity Amplifiers
- Long-Term Integrators/Filters
- Sample-and-Hold Amplifiers
- Peak Detectors
- Logarithmic Amplifiers
- Battery-Powered Systems

### GENERAL DESCRIPTION

The OP-497 is a quad op amp with precision performance in the space saving, industry standard 16-pin SOIC package. Its combination of exceptional precision with low power and extremely low input bias current makes the quad OP-497 useful in a wide variety of applications.

Precision performance of the OP-497 includes very low offset, under 50  $\mu$ V, and low drift, below 0.5  $\mu$ V/ $^{\circ}$ C. Open-loop gain exceeds 2000 V/mV insuring high linearity in every application. Errors due to common-mode signals are eliminated by the OP-497's common-mode rejection of over 120 dB. The OP-497's power supply rejection of over 120 dB minimizes offset voltage changes experienced in battery powered systems. Supply current of the OP-497 is under 625  $\mu$ A per amplifier, and it can operate with supply voltages as low as  $\pm$ 2 V.

The OP-497 utilizes a superbeta input stage with bias current cancellation to maintain picoamp bias currents at all temperatures. This is in contrast to FET input op amps whose bias currents start in the picoamp range at 25 $^{\circ}$ C, but double for every 10 $^{\circ}$ C rise in temperature, to reach the nanoamp range above 85 $^{\circ}$ C. Input bias current of the OP-497 is under 100 pA at 25 $^{\circ}$ C and is under 450 pA over the military temperature range.

Combining precision, low power and low bias current, the OP-497 is ideal for a number of applications including instrumentation amplifiers, log amplifiers, photo-diode preamplifiers and long term integrators. For a single device see the OP-97, for a dual see the OP-297.

### REV. C

Information furnished by Analog Devices is believed to be accurate and reliable. However, no responsibility is assumed by Analog Devices for its use, nor for any infringements of patents or other rights of third parties which may result from its use. No license is granted by implication or otherwise under any patent or patent rights of Analog Devices.

### PIN CONNECTIONS

16-Lead Wide Body SOIC  
(S Suffix)

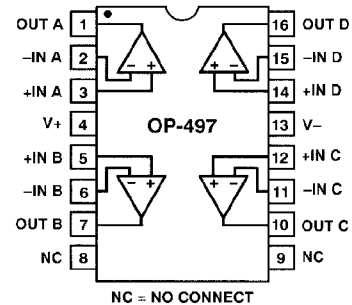

14-Lead Plastic Dip  
(P Suffix)

14-Lead Ceramic Dip  
(Y Suffix)

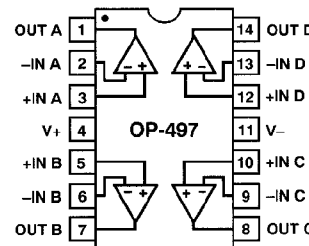

20-Position Chip Carrier  
(RC Suffix)

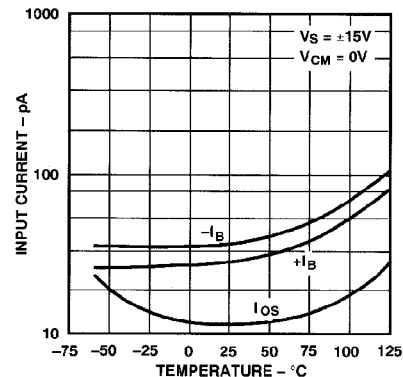
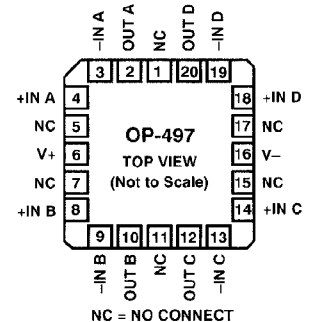

Input Bias, Offset Current vs. Temperature

# OP-497 — SPECIFICATIONS

## ELECTRICAL CHARACTERISTICS (@ $V_s = \pm 15\text{ V}$ , $T_A = +25^\circ\text{C}$ unless otherwise specified)

Parameter	Symbol	Condition	A			B/F			C/G			Units
			Min	Typ	Max	Min	Typ	Max	Min	Typ	Max	
<b>INPUT CHARACTERISTICS</b>												
Offset Voltage	$V_{OS}$	$-40^\circ\text{C} \leq T_A \leq +85^\circ\text{C}$	20	50		40	75		80	150		$\mu\text{V}$
		$-55^\circ\text{C} \leq T_A \leq +125^\circ\text{C}$	40	100		70	150		120	250		
Average Input Offset Voltage Drift	$TCV_{OS}$	$T_{min} - T_{max}$	0.2	0.5		0.4	1.0		0.6	1.5		$\mu\text{V}/^\circ\text{C}$
Long Term Input Offset Voltage Stability			0.1			0.1			0.1			$\mu\text{V}/\text{Mo}$
Input Bias Current	$I_B$	$V_{CM} = 0\text{ V}$ $-40^\circ\text{C} \leq T_A \leq +85^\circ\text{C}$	30	100		40	150		60	200		$\mu\text{A}$
		$-55^\circ\text{C} \leq T_A \leq +125^\circ\text{C}$	80	450		60	200		80	300		
Average Input Bias Current Drift	$TC_{IB}$	$-40^\circ\text{C} \leq T_A \leq +85^\circ\text{C}$				110	600		130	600		
		$-55^\circ\text{C} \leq T_A \leq +125^\circ\text{C}$	0.5			0.3			0.3			$\mu\text{A}/^\circ\text{C}$
Input Offset Current	$I_{OS}$	$V_{CM} = 0\text{ V}$ $40^\circ\text{C} \leq T_A \leq +85^\circ\text{C}$	15	100		30	150		50	200		$\mu\text{A}$
		$-55^\circ\text{C} \leq T_A \leq +125^\circ\text{C}$	35	400		50	200		80	300		
Average Input Offset Current Drift	$TC_{IOS}$		0.2			0.3			0.4			$\mu\text{A}/^\circ\text{C}$
Input Voltage Range <sup>1</sup>	IVR		$\pm 13$	$\pm 14$		$\pm 13$	$\pm 14$		$\pm 13$	$\pm 14$		V
Common-Mode Rejection	CMR	$T_{min} - T_{max}$ $V_{CM} = \pm 13\text{ V}$	$\pm 13$	$\pm 13.5$		$\pm 13$	$\pm 13.5$		$\pm 13$	$\pm 13.5$		dB
		$T_{min} - T_{max}$	120	140		114	135		114	135		
			114	130		108	120		108	120		
Large Signal Voltage Gain	$A_{VO}$	$V_O = \pm 10\text{ V}$ $R_L = 2\text{ k}\Omega$ $-40^\circ\text{C} < T_A < +85^\circ\text{C}$	2000	6000		1500	4000		1200	4000		V/mV
		$-55^\circ\text{C} < T_A < +125^\circ\text{C}$	1200	4000		800	2000		800	2000		
Input Resistance Differential Mode	$R_{IN}$		30			30			30			M $\Omega$
Input Resistance Common Mode	$R_{INCM}$		500			500			500			G $\Omega$
Input Capacitance	$C_{IN}$		3			3			3			pF
<b>OUTPUT CHARACTERISTICS</b>												
Output Voltage Swing	$V_O$	$R_L = 2\text{ k}\Omega$ $R_L = 10\text{ k}\Omega$	$\pm 13$	$\pm 13.7$		$\pm 13$	$\pm 13.7$		$\pm 13$	$\pm 13.7$		V
		$T_{min} - T_{max}$ , $R_L = 10\text{ k}\Omega$	$\pm 13$	$\pm 14$		$\pm 13$	$\pm 14$		$\pm 13$	$\pm 14$		
Short Circuit	$I_{SC}$		$\pm 13$	$\pm 13.5$		$\pm 13$	$\pm 13.5$		$\pm 13$	$\pm 13.5$		mA
			$\pm 25$			$\pm 25$			$\pm 25$			
<b>POWER SUPPLY</b>												
Power Supply Rejection Ratio	PSRR	$V_s = \pm 2\text{ V}$ to $\pm 20\text{ V}$ $V_s = \pm 2.5\text{ V}$ to $\pm 20\text{ V}$	120	140		114	135		114	135		dB
		$T_{min} - T_{max}$	114	130		108	120		108	120		
Supply Current (per Amplifier)	$I_{SY}$	No Load	525	625		525	625		525	625		$\mu\text{A}$
		$T_{min} - T_{max}$	580	750		580	750		580	750		
Supply Voltage Range	$V_s$	Operating Range	$\pm 2$	$\pm 20$		$\pm 2$	$\pm 20$		$\pm 2$	$\pm 20$		V
		$T_{min} - T_{max}$	$\pm 2.5$	$\pm 20$		$\pm 2.5$	$\pm 20$		$\pm 2.5$	$\pm 20$		
<b>DYNAMIC PERFORMANCE</b>												
Slew Rate	SR		0.05	0.15		0.05	0.15		0.05	0.15		V/ $\mu\text{s}$
Gain Bandwidth Product	GBW		500			500			500			kHz
Channel Separation	CS	$V_O = 20\text{ V}$ p-p $f_o = 10\text{ Hz}$	150			150			150			dB
<b>NOISE PERFORMANCE</b>												
Voltage Noise	$e_n$ p-p	0.1 Hz to 10 Hz	0.3			0.3			0.3			$\mu\text{V}$ p-p
Voltage Noise Density	$e_n = 10\text{ Hz}$		17			17			17			nV/ $\sqrt{\text{Hz}}$
	$e_n = 1\text{ kHz}$		15			15			15			nV/ $\sqrt{\text{Hz}}$
Current Noise Density	$i_n = 10\text{ Hz}$		20			20			20			fA/ $\sqrt{\text{Hz}}$

### NOTE

<sup>1</sup>Guaranteed by CMR Test.

Specifications subject to change without notice.

**WAFER TEST LIMITS** (@  $V_S = \pm 15\text{ V}$ ,  $T_A = +25^\circ\text{C}$ , unless otherwise noted)

Parameter	Symbol	Condition	OP-497 GBC Limit	Units
Input Offset Voltage	$V_{OS}$		150	$\mu\text{V}$ max
Input Offset Current	$I_{OS}$	$V_{CM} = 0\text{ V}$	150	pA max
Input Bias Current	$I_B$	$V_{CM} = 0\text{ V}$	150	pA max
Input Voltage Range <sup>1</sup>	IVR		$\pm 13$	V min
Large Signal Voltage Gain	$A_{VO}$	$V_O = \pm 10\text{ V}$ , $R_L \leq 10\text{ k}\Omega$	1500	V/mV min
Common-Mode Rejection	CMR	$V_{CM} = \pm 13\text{ V}$	114	dB min
Power Supply Rejection	PSR	$V_S = \pm 2\text{ V}$ to $\pm 20\text{ V}$	114	dB min
Output Voltage Swing	$V_O$	$R_L \leq 10\text{ k}\Omega$	$\pm 13$	V min
		$R_L \leq 2\text{ k}\Omega$	$\pm 13$	V min
Supply Current per Amplifier	$I_{SY}$	No Load	625	$\mu\text{A}$ max

NOTE

<sup>1</sup>Guaranteed by CMR test. Electrical tests are performed at wafer probe to the limits shown. Due to variations in assembly methods and normal yield loss, yield after packaging is not guaranteed for standard product dice. Consult factory to negotiate specifications based on dice lot qualifications through sample lot assembly and testing.

**ABSOLUTE MAXIMUM RATINGS<sup>1</sup>**

Supply Voltage	$\pm 20\text{ V}$
Input Voltage <sup>2</sup>	$+20\text{ V}$
Differential Input Voltage <sup>2</sup>	$40\text{ V}$
Output Short-Circuit Duration	Indefinite
Storage Temperature Range	
Y, RC Package	$-65^\circ\text{C}$ to $+175^\circ\text{C}$
P, S Package	$-65^\circ\text{C}$ to $+150^\circ\text{C}$
Operating Temperature Range	
OP-497A, B, C (Y)	$-55^\circ\text{C}$ to $+125^\circ\text{C}$
OP-497F, G (Y)	$-40^\circ\text{C}$ to $+85^\circ\text{C}$
OP-497F, G (P, S)	$-40^\circ\text{C}$ to $+85^\circ\text{C}$
Junction Temperature	
Y, RC Package	$-65^\circ\text{C}$ to $+175^\circ\text{C}$
P, S Package	$-65^\circ\text{C}$ to $+150^\circ\text{C}$
Lead Temperature Range (Soldering, 60 sec)	$+300^\circ\text{C}$

Package Type	$\theta_{JA}$ <sup>3</sup>	$\theta_{JC}$	Units
14-Pin Cerdip (Y)	94	10	$^\circ\text{C}/\text{W}$
14-Pin Plastic DIP (P)	76	33	$^\circ\text{C}/\text{W}$
20-Contact LCC (RC)	78	33	$^\circ\text{C}/\text{W}$
16-Pin SOIC (S)	92	23	$^\circ\text{C}/\text{W}$

NOTES

- <sup>1</sup>Absolute maximum ratings apply to both DICE and packaged parts, unless otherwise noted.
- <sup>2</sup>For supply voltages less than  $\pm 20\text{ V}$ , the absolute maximum input voltage is equal to the supply voltage.
- <sup>3</sup> $\theta_{JA}$  is specified for worst case mounting conditions, i.e.,  $\theta_{JA}$  is specified for device in socket for cerdip, P-DIP, and LCC packages;  $\theta_{JA}$  is specified for device soldered to printed circuit board for SOIC package.

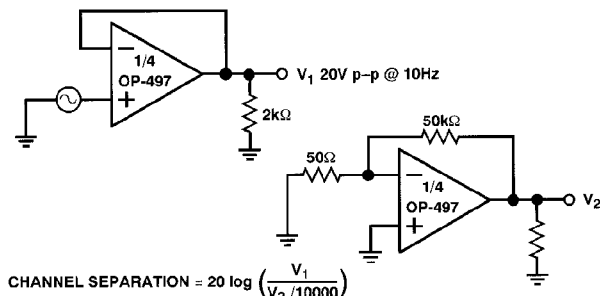

Channel Separation Test Circuit

**ORDERING GUIDE**

Model	Temperature Range	Package Description	Package Option
OP497AY	$-55^\circ\text{C}$ to $+125^\circ\text{C}$	14-Pin Cerdip	Q-14
OP497BY	$-55^\circ\text{C}$ to $+125^\circ\text{C}$	14-Pin Cerdip	Q-14
OP497CY	$-55^\circ\text{C}$ to $+125^\circ\text{C}$	14-Pin Cerdip	Q-14
OP497BRC/883	$-55^\circ\text{C}$ to $+125^\circ\text{C}$	20-Contact LCC	E-20A
OP497FY	$-40^\circ\text{C}$ to $+85^\circ\text{C}$	14-Pin Cerdip	Q-14
OP497FP	$-40^\circ\text{C}$ to $+85^\circ\text{C}$	14-Pin Plastic DIP	N-14
OP497FS	$-40^\circ\text{C}$ to $+85^\circ\text{C}$	16-Pin SOIC	R-16
OP497GY	$-40^\circ\text{C}$ to $+85^\circ\text{C}$	14-Pin Cerdip	Q-14
OP497GP	$-40^\circ\text{C}$ to $+85^\circ\text{C}$	14-Pin Plastic DIP	N-14
OP497GS	$-40^\circ\text{C}$ to $+85^\circ\text{C}$	16-Pin SOIC	R-16

**DICE CHARACTERISTICS**

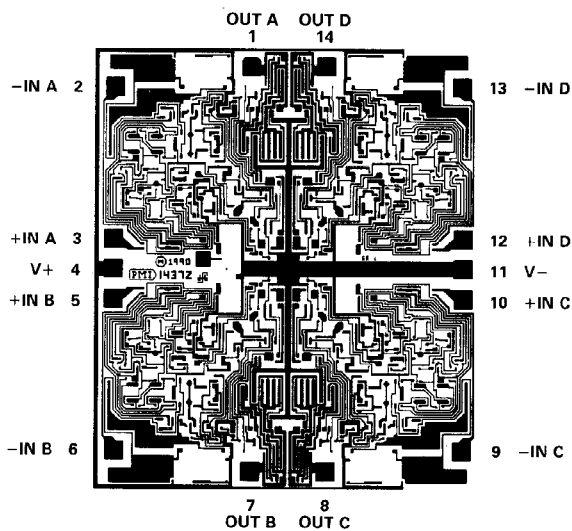

Die Size  $0.112 \times 0.129$  inch, 14,448 sq. mils

# OP-497 — Typical Characteristics (@ +25°C, $V_S = \pm 15V$ , unless otherwise noted)

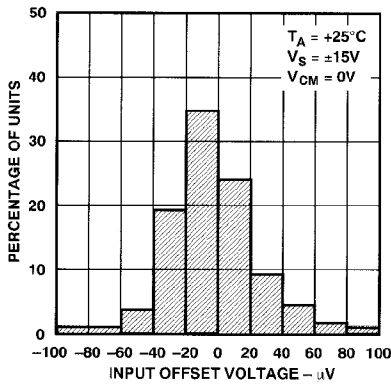

Figure 1. Typical Distribution of Input Offset Voltage

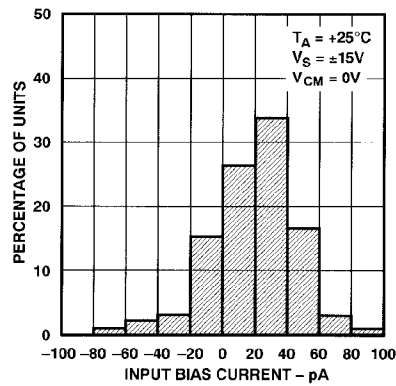

Figure 2. Typical Distribution of Input Bias Current

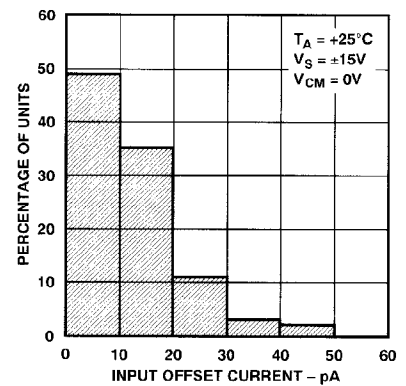

Figure 3. Typical Distribution of Input Offset Current

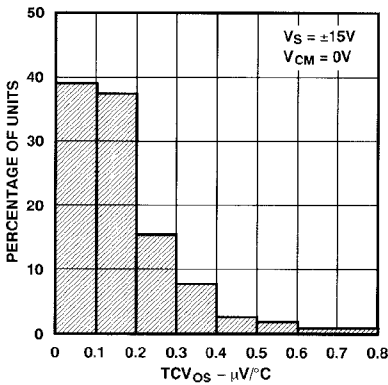

Figure 4. Typical Distribution of  $TCV_{OS}$

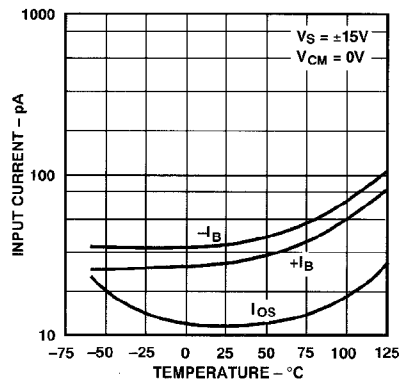

Figure 5. Input Bias, Offset Current vs. Temperature

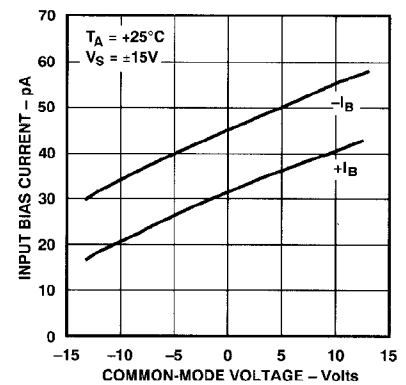

Figure 6. Input Bias Current vs. Common-Mode Voltage

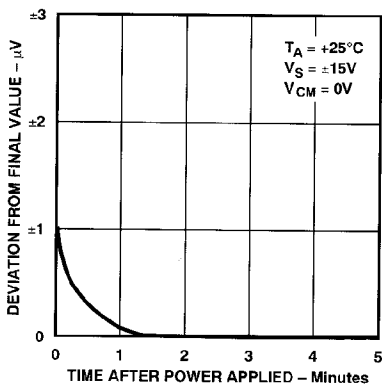

Figure 7. Input Offset Voltage Warm-Up Drift

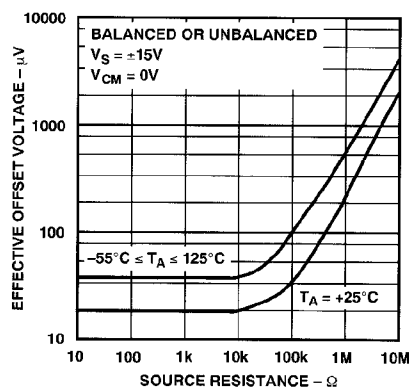

Figure 8. Effective Offset Voltage vs. Source Resistance

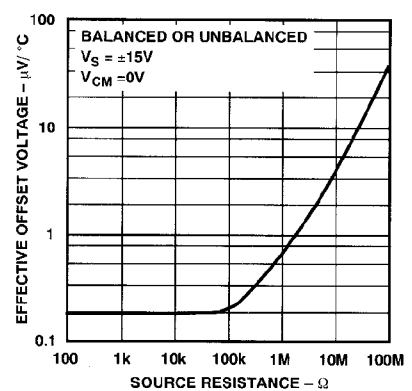

Figure 9. Effective  $TCV_{OS}$  vs. Source Resistance

# Typical Characteristics (@ +25°C, $V_S = \pm 15V$ , unless otherwise noted) — OP-497

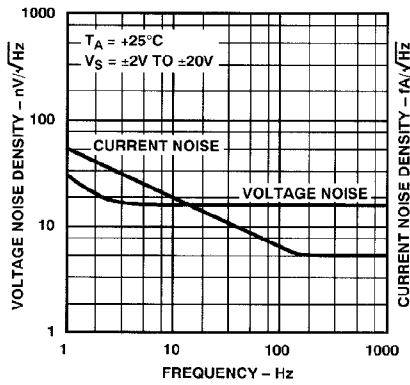

Figure 10. Voltage Noise Density vs. Frequency

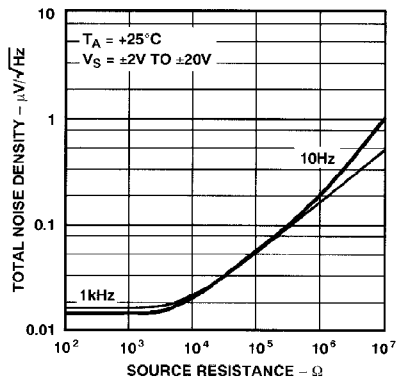

Figure 11. Total Noise Density vs. Source Resistance

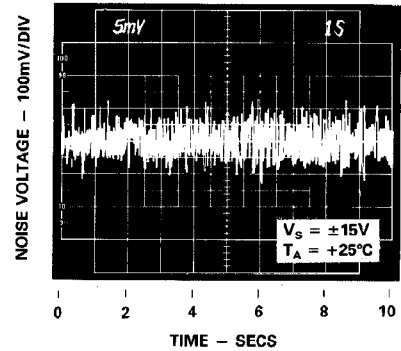

Figure 12. 0.1 Hz to 10 Hz Noise Voltage

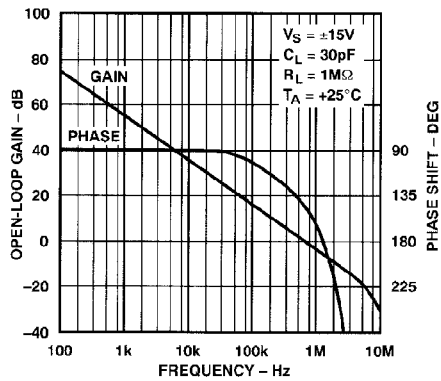

Figure 13. Open-Loop Gain, Phase vs. Frequency

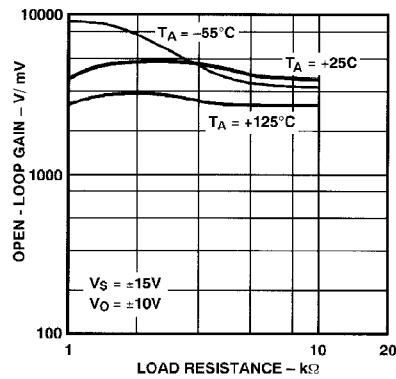

Figure 14. Open-Loop Gain vs. Load Resistance

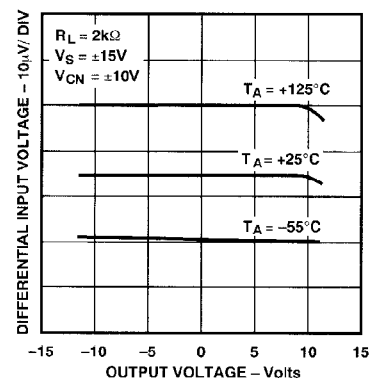

Figure 15. Open-Loop Gain Linearity

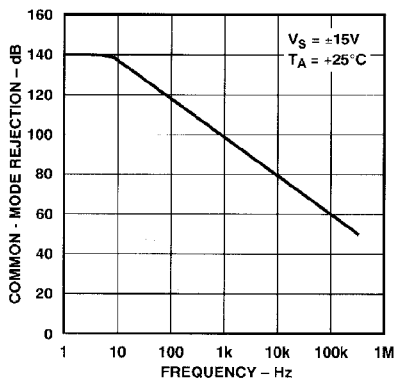

Figure 16. Common-Mode Rejection vs. Frequency

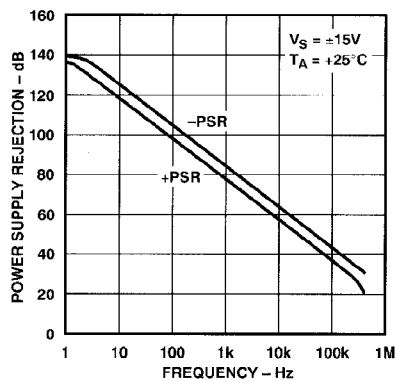

Figure 17. Power Supply Rejection vs. Frequency

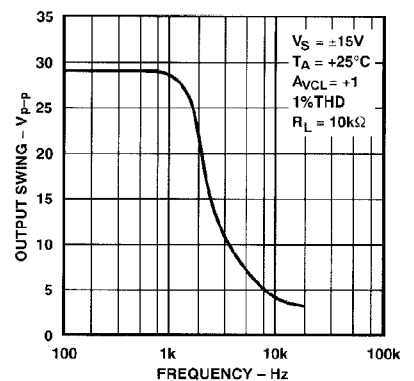

Figure 18. Maximum Output Swing vs. Frequency

# OP-497 — Typical Characteristics (@ +25°C, $V_S = \pm 15\text{ V}$ , unless otherwise noted)

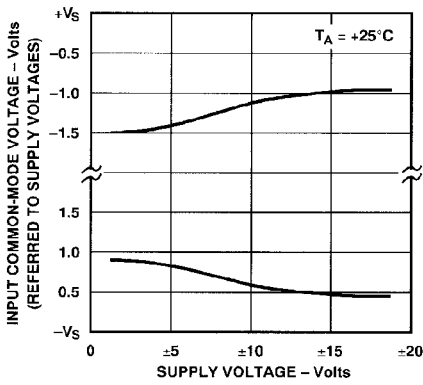

Figure 19. Input Common-Mode Voltage Range vs. Supply Voltage

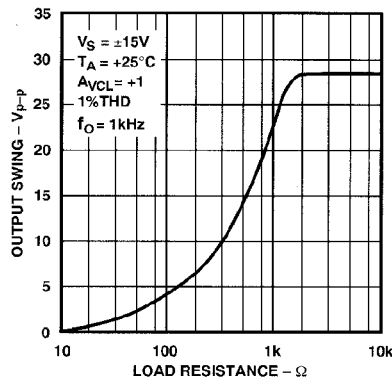

Figure 20. Maximum Output Swing vs. Load Resistance

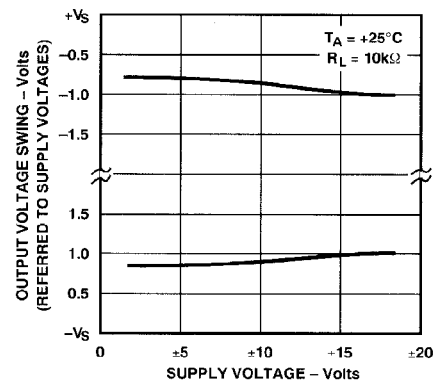

Figure 21. Output Voltage Swing vs. Supply Voltage

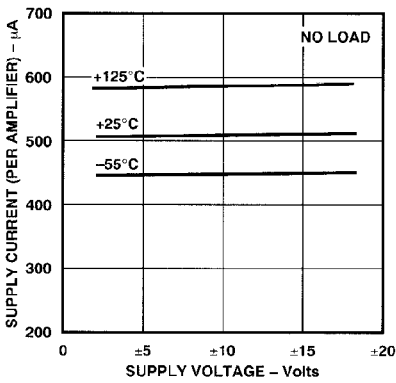

Figure 22. Supply Current (per Amplifier) vs. Supply Voltage

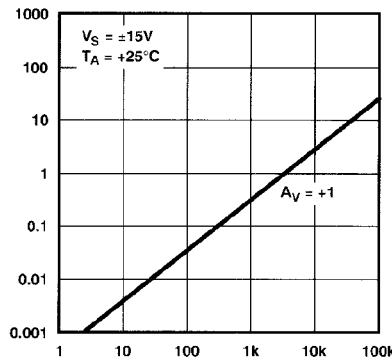

Figure 23. Closed-Loop Output Impedance vs. Frequency

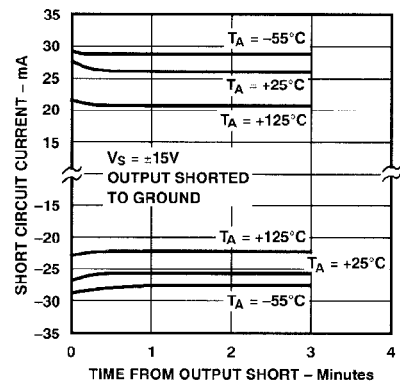

Figure 24. Short-Circuit Current vs. Time Temperature

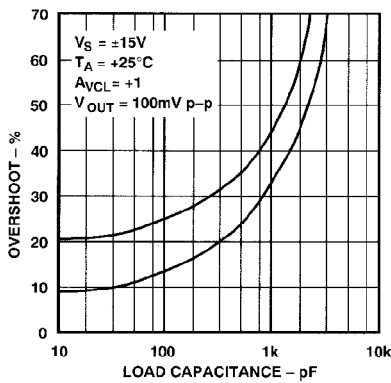

Figure 25. Small-Signal Overshoot vs. Capacitance Load

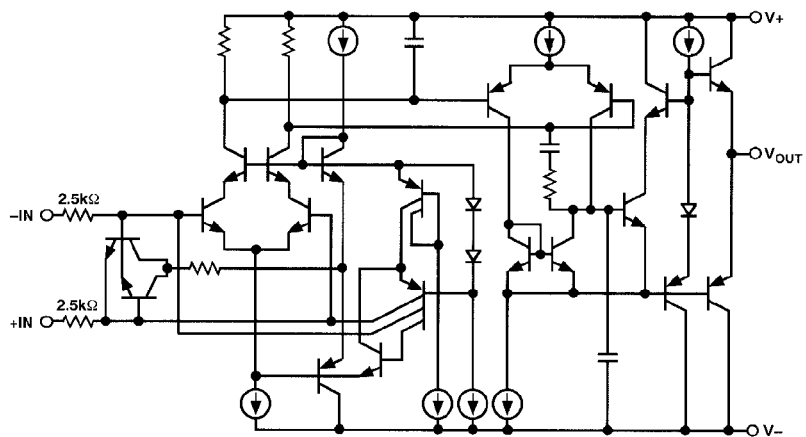

Figure 26. Simplified Schematic Showing One Amplifier

**APPLICATIONS INFORMATION**

Extremely low bias current over the full military temperature range makes the OP-497 attractive for use in sample-and-hold amplifiers, peak detectors, and log amplifiers that must operate over a wide temperature range. Balancing input resistances is not necessary with the OP-497. Offset voltage and  $TCV_{OS}$  are degraded only minimally by high source resistance, even when unbalanced.

The input pins of the OP-497 are protected against large differential voltage by back-to-back diodes and current-limiting resistors. Common-mode voltages at the inputs are not restricted, and may vary over the full range of the supply voltages used.

The OP-497 requires very little operating headroom about the supply rails, and is specified for operation with supplies as low as  $\pm 2$  V. Typically, the common-mode range extends to within one volt of either rail. The output typically swings to within one volt of the rails when using a 10 k $\Omega$  load.

**AC PERFORMANCE**

The OP-497's ac characteristics are highly stable over its full operating temperature range. Unity-gain small-signal response is shown in Figure 27. Extremely tolerant of capacitive loading on the output, the OP-497 displays excellent response even with 1000 pF loads (Figure 28).

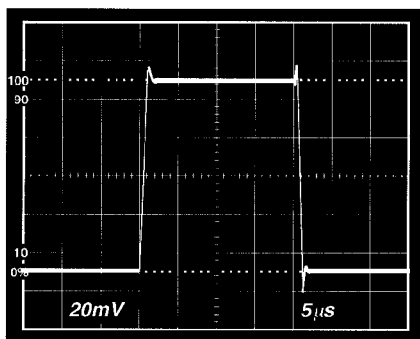

Figure 27. Small Signal Transient Response ( $C_{LOAD} = 100$  pF,  $A_{VCL} = +1$ )

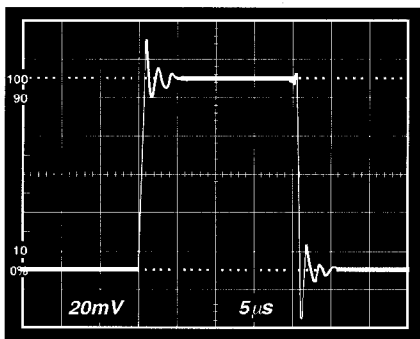

Figure 28. Small Signal Transient Response ( $C_{LOAD} = 1000$  pF,  $A_{VCL} = +1$ )

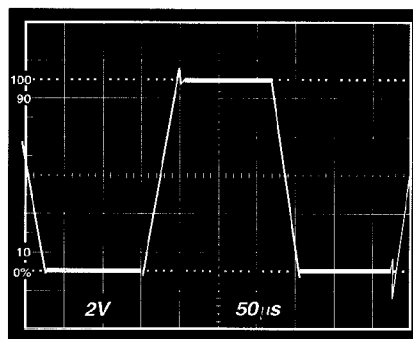

Figure 29. Large Signal Transient Response ( $A_{VCL} = +1$ )

**GUARDING AND SHIELDING**

To maintain the extremely high input impedances of the OP-497, care must be taken in circuit board layout and manufacturing. Board surfaces must be kept scrupulously clean and free of moisture. Conformal coating is recommended to provide a humidity barrier. Even a clean PC board can have 100 pA of leakage currents between adjacent traces, so guard rings should be used around the inputs. Guard traces are operated at a voltage close to that on the inputs, as shown in Figure 30, so that leakage currents become minimal. In noninverting applications, the guard ring should be connected to the common-mode voltage at the inverting input. In inverting applications, both inputs remain at ground, so the guard trace should be grounded. Guard traces should be on both sides of the circuit board.

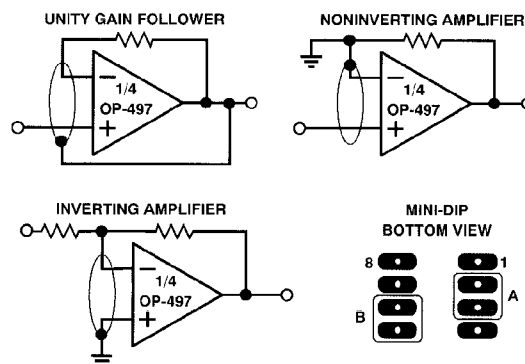

Figure 30. Guard Ring Layout and Connections

# OP-497

## OPEN-LOOP GAIN LINEARITY

The OP-497 has both an extremely high gain of 2000 V/mv minimum and constant gain linearity. This enhances the precision of the OP-497 and provides for very high accuracy in high closed-loop gain applications. Figure 31 illustrates the typical open-loop gain linearity of the OP-497 over the military temperature range.

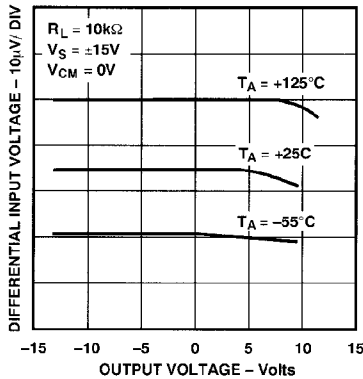

Figure 31. Open-Loop Linearity of the OP-497

## APPLICATIONS

### Precision Absolute Value Amplifier

The circuit of Figure 32 is a precision absolute value amplifier with an input impedance of  $30\text{ M}\Omega$ . The high gain and low  $\text{TCV}_{OS}$  of the OP-497 insure accurate operation with microvolt input signals. In this circuit, the input always appears as a common-mode signal to the op amps. The CMR of the OP-497 exceeds 120 dB, yielding an error of less than 2 ppm.

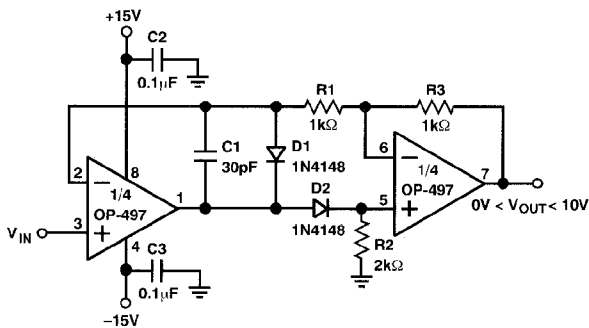

Figure 32. Precision Absolute Value Amplifier

## PRECISION CURRENT PUMP

Maximum output current of the precision current pump shown in Figure 33 is  $\pm 10\text{ mA}$ . Voltage compliance is  $\pm 10\text{ V}$  with  $\pm 15\text{ V}$  supplies. Output impedance of the current transmitter exceeds  $3\text{ M}\Omega$  with linearity better than 16 bits.

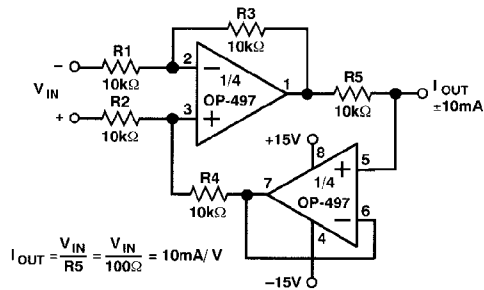

Figure 33. Precision Current Pump

## PRECISION POSITIVE PEAK DETECTOR

In Figure 34, the  $C_H$  must be of polystyrene, Teflon\*, or polyethylene to minimize dielectric absorption and leakage. The droop rate is determined by the size of  $C_H$  and the bias current of the OP-497.

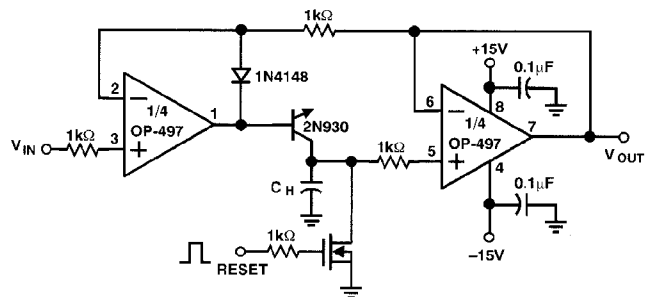

Figure 34. Precision Positive Peak Detector

## SIMPLE BRIDGE CONDITIONING AMPLIFIER

Figure 35 shows a simple bridge conditioning amplifier using the OP-497. The transfer function is:

$$V_{OUT} = V_{REF} \left( \frac{\Delta R}{R + \Delta R} \right) \frac{R_F}{R}$$

The REF-43 provides an accurate and stable reference voltage for the bridge. To maintain the highest circuit accuracy,  $R_F$  should be 0.1% or better with a low temperature coefficient.

\*Teflon is a registered trademark of the Dupont Company.

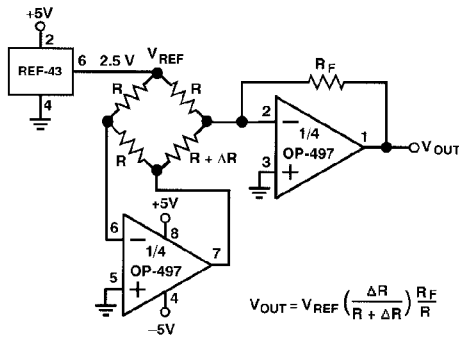

Figure 35. A Simple Bridge Conditioning Amplifier Using the OP-497

**NONLINEAR CIRCUITS**

Due to its low input bias currents, the OP-497 is an ideal log amplifier in nonlinear circuits such as the square and square-root circuits shown in Figures 36 and 37. Using the squaring circuit of Figure 36 as an example, the analysis begins by writing a voltage loop equation across transistors Q<sub>1</sub>, Q<sub>2</sub>, Q<sub>3</sub> and Q<sub>4</sub>.

$$V_{T1} \ln \left( \frac{I_{IN}}{I_{S1}} \right) + V_{T2} \ln \left( \frac{I_{IN}}{I_{S2}} \right) = V_{T3} \ln \left( \frac{I_O}{I_{S3}} \right) + V_{T4} \ln \left( \frac{I_{REF}}{I_{S4}} \right)$$

All the transistors of the MAT-04 are precisely matched and at the same temperature, so the I<sub>S</sub> and V<sub>T</sub> terms cancel, giving:

$$2 \ln I_{IN} = \ln I_O + \ln I_{REF} = \ln (I_O \times I_{REF})$$

Exponentiating both sides of the equation leads to:

$$I_O = \frac{(I_{IN})^2}{I_{REF}}$$

Op amp A<sub>2</sub> forms a current-to-voltage converter which gives V<sub>OUT</sub> = R<sub>2</sub> × I<sub>O</sub>. Substituting (V<sub>IN</sub>/R<sub>1</sub>) for I<sub>IN</sub> and the above equation for I<sub>O</sub> yields:

$$V_{OUT} = \left( \frac{R_2}{I_{REF}} \right) \left( \frac{V_{IN}}{R_1} \right)^2$$

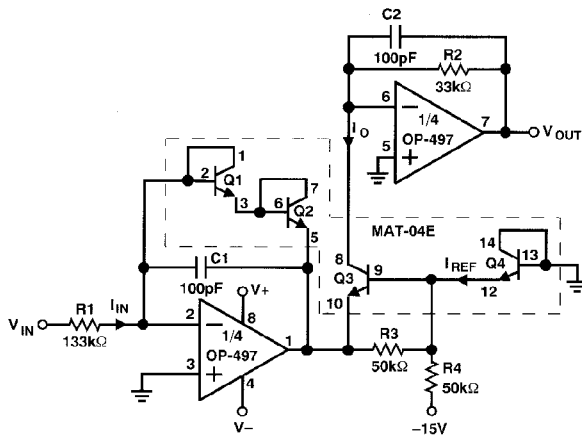

Figure 36. Squaring Amplifier

A similar analysis made for the square-root circuit of Figure 37 leads to its transfer function:

$$V_{OUT} = R_2 \sqrt{\frac{(V_{IN}) (I_{REF})}{R_1}}$$

In these circuits, I<sub>REF</sub> is a function of the negative power supply. To maintain accuracy, the negative supply should be well regulated. For applications where very high accuracy is required, a voltage reference may be used to set I<sub>REF</sub>. An important consideration for the squaring circuit is that a sufficiently large input voltage can force the output beyond the operating range of the output op amp. Resistor R<sub>4</sub> can be changed to scale I<sub>REF</sub>, or R<sub>1</sub> and R<sub>2</sub> can be varied to keep the output voltage within the usable range.

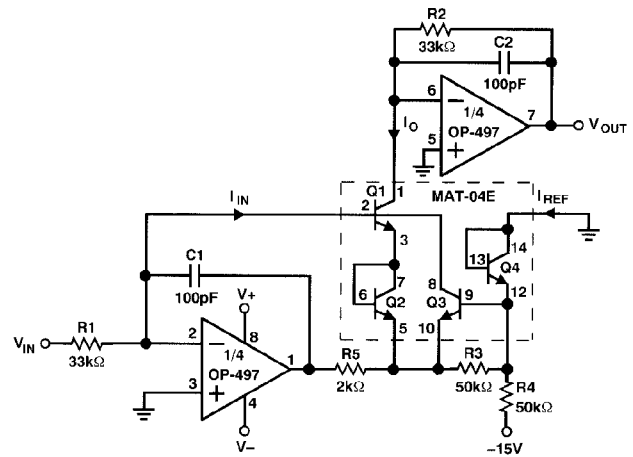

Figure 37. Square Root Amplifier

Unadjusted accuracy of the square-root circuit is better than 0.1% over an input voltage range of 100 mV to 10 V. For a similar input voltage range, the accuracy of the squaring circuit is better than 0.5%.

# OP-497

## OP-497 SPICE MACRO-MODEL

Figure 38 and Table I show the node and net list for a SPICE macro-model of the OP-497. The model is a simplified version of the actual device and simulates important dc parameters such as  $V_{OS}$ ,  $I_{OS}$ ,  $I_B$ ,  $A_{VO}$ ,  $CMR$ ,  $V_O$  and  $I_{SY}$ . AC parameters such as slew rate, gain and phase response and  $CMR$  change with frequency are also simulated by the model.

The model uses typical parameters for the OP-497. The poles and zeros in the model were determined from the actual open and closed-loop gain and phase response of the OP-497. In this way, the model presents an accurate ac representation of the actual device. The model assumes an ambient temperature of 25°C.

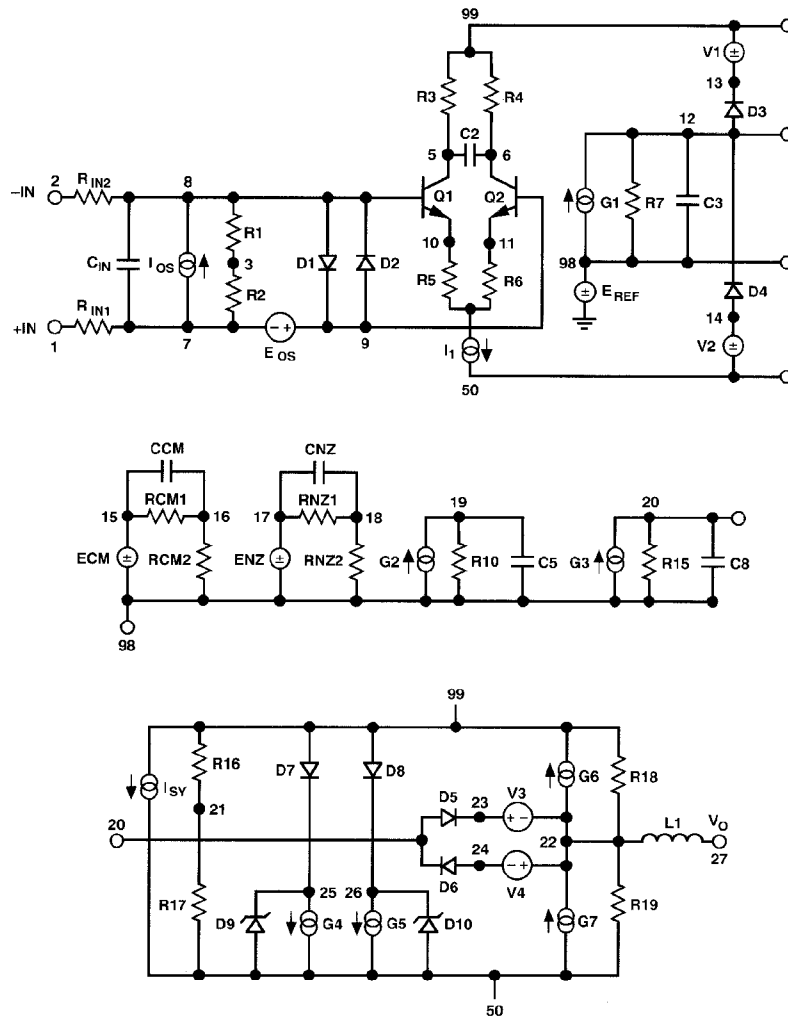

Figure 38. OP-497 Macro Model

Table I. OP-497 SPICE Net-List

```

*NODE ASSIGNMENTS
*
*          NONINVERTING INPUT
*          INVERTING INPUT
*          POSITIVE SUPPLY
*          NEGATIVE SUPPLY
*          OUTPUT
*
*SUBCKT OP-497      1  2  99  50  27
*
*INPUT STAGE & POLE AT 6 MHz
*
RIN1  1  7  2500
RIN2  2  8  2500
R1    8  3  6.782E8
R2    7  3  6.782E8
R3    5  99 542.57
R4    6  99 542.57
CIN   7  8  3E-12
C2    5  6  24.445E-12
I1    4  50 0.1E-3
IOS   7  8  15E-12
EOS   9  7  POLY(1)      16  21  40E-6  1
Q1    5  8  10          QX
Q2    6  9  11          QX
R5    10 4  25.374
R6    11 4  25.374
D1    8  9  DX
D2    9  8  DX
*
EREF  98 0  21      0  1
*
*GAIN STAGE & DOMINANT POLE AT 0.11 Hz
*
R7    12 98 2.1703E9
C3    12 98 666.67E-12
G1    98 12 5          6  1.8431E-3
V1    99 13 1.275
V2    14 50 1.275
D3    12 13 DX
D4    14 12 DX
*
*COMMON-MODE GAIN NETWORK WITH ZERO AT 50 Hz
*
RCM1  15 16 1E6
CCM   15 16 3.183E-9
RCM2  16 98 1
ECM   15 98 3      21  177.83E-3
*
*NEGATIVE ZERO AT 1.8 MHz
*
E1    17 98 12      21  1E6
R8    17 18 1E6
C4    17 18 -88.419E-15
R9    18 98 1
*
*POLE AT 6 MHz
*
G2    98 19 18      21  1E-6
R10   19 98 1E6
C5    19 98 26.526E-15
*
*POLE AT 1.8 MHz
*
G3    98 20 19      21  1E-6
R15   20 98 1E6
C8    20 98 88.419E-15
*
*OUTPUT STAGE
*
R16   99 21 160k
R17   21 50 160k
ISY   99 50 331E-6
V3    23 22 1.9
D5    20 23 DX
V4    22 24 1.9
D6    24 20 DX
D7    99 25 DX
G4    25 50 20      22  5E-3
D9    50 25 DY
D8    99 26 DX
G5    26 50 22      20  5E-3
D10   50 26 DY
G6    22 99 99      20  5E-3
R18   99 22 200
G7    50 22 20      50  5E-3
R19   22 50 200
L1    22 27 0.1E-6
*
*MODELS USED
*
.MODEL QX NPN (BF = 1.25E6)
.MODEL DX D (IS = 1E-15)
.MODEL DY D (IS = 1E-15 BV = 50)
.ENDS OP-497

```

**OUTLINE DIMENSIONS**  
(Dimensions shown in inches and (mm)).

**14-Lead Ceramic DIP  
(Y Suffix)**

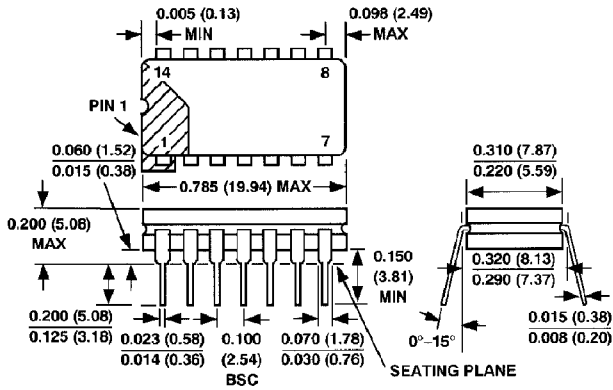

**14-Lead Epoxy DIP  
(P Suffix)**

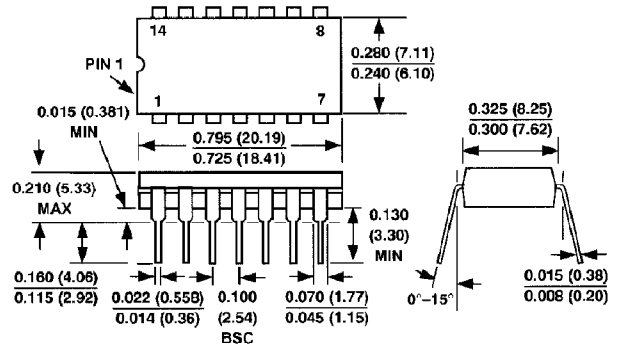

**20-Position Chip Carrier  
(RC Suffix)**

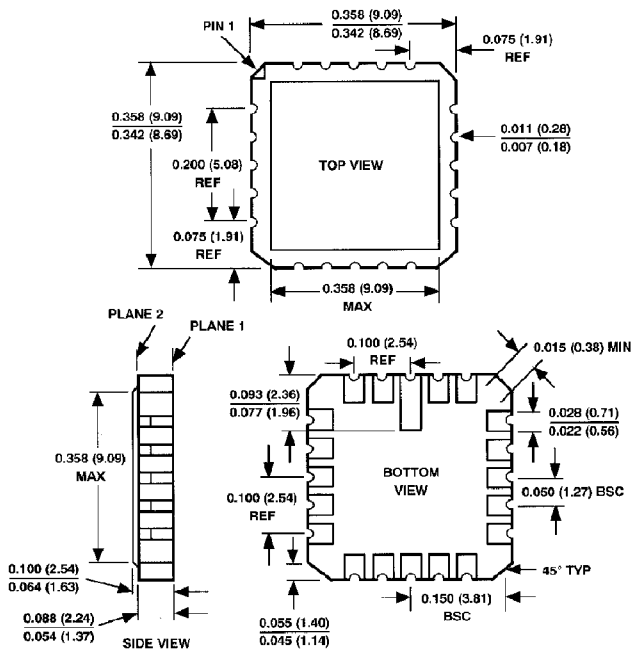

**16-Lead Wide-Body SOIC  
(S Suffix)**

