

## ADG733/ADG734

### FEATURES

- 1.8 V to 5.5 V Single Supply
- $\pm 3$  V Dual Supply
- 2.5  $\Omega$  On Resistance
- 0.5  $\Omega$  On Resistance Flatness
- 100 pA Leakage Currents
- 19 ns Switching Times
- Triple SPDT: ADG733
- Quad SPDT: ADG734
- Small TSSOP and QSOP Packages
- Low Power Consumption
- TTL/CMOS-Compatible Inputs

### APPLICATIONS

- Data Acquisition Systems
- Communication Systems
- Relay Replacement
- Audio and Video Switching
- Battery-Powered Systems

### GENERAL DESCRIPTION

The ADG733 and ADG734 are low voltage, CMOS devices comprising three independently selectable SPDT (single pole, double throw) switches and four independently selectable SPDT switches respectively.

Low power consumption and operating supply range of 1.8 V to 5.5 V and dual  $\pm 3$  V make the ADG733 and ADG734 ideal for battery powered, portable instruments. All channels exhibit break-before-make switching action preventing momentary shorting when switching channels. An  $\overline{\text{EN}}$  input on the ADG733 is used to enable or disable the device. When disabled, all channels are switched OFF.

These 2–1 multiplexers/SPDT switches are designed on an enhanced submicron process that provides low power dissipation yet gives high switching speed, very low on resistance, high signal bandwidths and low leakage currents. On resistance is in the region of a few ohms, is closely matched between switches and very flat over the full signal range. These parts can operate equally well in either direction and have an input signal range which extends to the supplies.

The ADG733 is available in small TSSOP and QSOP packages, while the ADG734 is available in a small TSSOP package.

REV. 0

Information furnished by Analog Devices is believed to be accurate and reliable. However, no responsibility is assumed by Analog Devices for its use, nor for any infringements of patents or other rights of third parties which may result from its use. No license is granted by implication or otherwise under any patent or patent rights of Analog Devices.

### FUNCTIONAL BLOCK DIAGRAMS

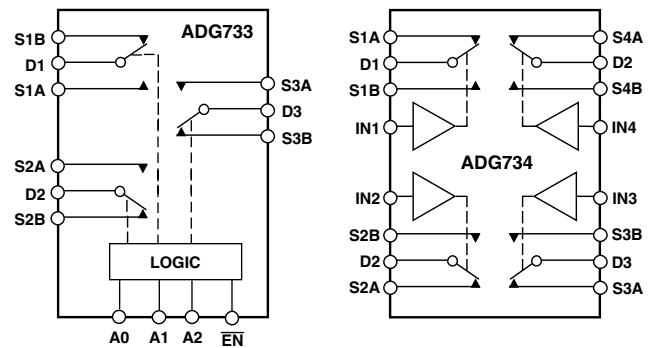

SWITCHES SHOWN FOR A "1" INPUT LOGIC

### PRODUCT HIGHLIGHTS

1. Single/Dual Supply Operation. The ADG733 and ADG734 are fully specified and guaranteed with 3 V and 5 V single supply rails and  $\pm 3$  V dual supply rails.
2. Low On Resistance (2.5  $\Omega$  typical).
3. Low Power Consumption ( $< 0.01 \mu\text{W}$ ).
4. Guaranteed Break-Before-Make Switching Action.

# ADG733/ADG734—SPECIFICATIONS<sup>1</sup> ( $V_{DD} = 5\text{ V} \pm 10\%$ , $V_{SS} = 0\text{ V}$ , $GND = 0\text{ V}$ , unless otherwise noted.)

Parameter	B Version		Unit	Test Conditions/Comments
	25°C	-40°C to +85°C		
<b>ANALOG SWITCH</b>				
Analog Signal Range		0 V to $V_{DD}$	V	
On Resistance ( $R_{ON}$ )	2.5		$\Omega$ typ	$V_S = 0\text{ V}$ to $V_{DD}$ , $I_{DS} = 10\text{ mA}$ ; Test Circuit 1
	4.5	5.0	$\Omega$ max	
On-Resistance Match between Channels ( $\Delta R_{ON}$ )		0.1	$\Omega$ typ	$V_S = 0\text{ V}$ to $V_{DD}$ , $I_{DS} = 10\text{ mA}$
		0.4	$\Omega$ max	
On-Resistance Flatness ( $R_{FLAT(ON)}$ )	0.5		$\Omega$ typ	$V_S = 0\text{ V}$ to $V_{DD}$ , $I_{DS} = 10\text{ mA}$
		1.2	$\Omega$ max	
<b>LEAKAGE CURRENTS</b>				
Source OFF Leakage $I_S$ (OFF)	$\pm 0.01$		nA typ	$V_{DD} = 5.5\text{ V}$ $V_D = 4.5\text{ V}/1\text{ V}$ , $V_S = 1\text{ V}/4.5\text{ V}$ ; Test Circuit 2
	$\pm 0.1$	$\pm 0.3$	nA max	
Channel ON Leakage $I_D$ , $I_S$ (ON)	$\pm 0.01$		nA typ	$V_D = V_S = 1\text{ V}$ , or $4.5\text{ V}$ ; Test Circuit 3
	$\pm 0.1$	$\pm 0.5$	nA max	
<b>DIGITAL INPUTS</b>				
Input High Voltage, $V_{INH}$		2.4	V min	
Input Low Voltage, $V_{INL}$		0.8	V max	
Input Current				
$I_{INL}$ or $I_{INH}$	0.005		$\mu\text{A}$ typ	$V_{IN} = V_{INL}$ or $V_{INH}$
		$\pm 0.1$	$\mu\text{A}$ max	
$C_{IN}$ , Digital Input Capacitance	4		pF typ	
<b>DYNAMIC CHARACTERISTICS<sup>2</sup></b>				
$t_{ON}$	19		ns typ	$R_L = 300\ \Omega$ , $C_L = 35\text{ pF}$ ; $V_S = 3\text{ V}$ , Test Circuit 4
		34	ns max	
$t_{OFF}$	7		ns typ	$R_L = 300\ \Omega$ , $C_L = 35\text{ pF}$ ; $V_S = 3\text{ V}$ , Test Circuit 4
		12	ns max	
ADG733 $t_{ON}(\overline{EN})$	20		ns typ	$R_L = 300\ \Omega$ , $C_L = 35\text{ pF}$ ; $V_S = 3\text{ V}$ , Test Circuit 5
		40	ns max	
$t_{OFF}(\overline{EN})$	7		ns typ	$R_L = 300\ \Omega$ , $C_L = 35\text{ pF}$ ; $V_S = 3\text{ V}$ , Test Circuit 5
		12	ns max	
Break-Before-Make Time Delay, $t_D$	13		ns typ	$R_L = 300\ \Omega$ , $C_L = 35\text{ pF}$ ; $V_S = 3\text{ V}$ , Test Circuit 6
		1	ns min	
Charge Injection	$\pm 3$		pC typ	$V_S = 2\text{ V}$ , $R_S = 0\ \Omega$ , $C_L = 1\text{ nF}$ ; Test Circuit 7
Off Isolation	-62		dB typ	$R_L = 50\ \Omega$ , $C_L = 5\text{ pF}$ , $f = 10\text{ MHz}$ ; $R_L = 50\ \Omega$ , $C_L = 5\text{ pF}$ , $f = 1\text{ MHz}$ ; Test Circuit 8
	-82		dB typ	
Channel-to-Channel Crosstalk	-62		dB typ	$R_L = 50\ \Omega$ , $C_L = 5\text{ pF}$ , $f = 10\text{ MHz}$ ; $R_L = 50\ \Omega$ , $C_L = 5\text{ pF}$ , $f = 1\text{ MHz}$ ; Test Circuit 9
	-82		dB typ	
-3 dB Bandwidth	200		MHz typ	$R_L = 50\ \Omega$ , $C_L = 5\text{ pF}$ , Test Circuit 8
$C_S$ (OFF)	11		pF typ	
$C_D$ , $C_S$ (ON)	34		pF typ	
<b>POWER REQUIREMENTS</b>				
$I_{DD}$	0.001		$\mu\text{A}$ typ	$V_{DD} = 5.5\text{ V}$ Digital Inputs = 0 V or 5.5 V
		1.0	$\mu\text{A}$ max	

## NOTES

<sup>1</sup>Temperature range is as follows: B Version: -40°C to +85°C.

<sup>2</sup>Guaranteed by design, not subject to production test.

Specifications subject to change without notice.

# SPECIFICATIONS<sup>1</sup> ( $V_{DD} = 3\text{ V} \pm 10\%$ , $V_{SS} = 0\text{ V}$ , $GND = 0\text{ V}$ , unless otherwise noted.)

Parameter	B Version		Unit	Test Conditions/Comments
	25°C	-40°C to +85°C		
<b>ANALOG SWITCH</b>				
Analog Signal Range		0 V to $V_{DD}$	V	
On Resistance ( $R_{ON}$ )	6		$\Omega$ typ	$V_S = 0\text{ V}$ to $V_{DD}$ , $I_{DS} = 10\text{ mA}$ ; Test Circuit 1
	11	12	$\Omega$ max	
On-Resistance Match between Channels ( $\Delta R_{ON}$ )		0.1	$\Omega$ typ	$V_S = 0\text{ V}$ to $V_{DD}$ , $I_{DS} = 10\text{ mA}$
On-Resistance Flatness ( $R_{FLAT(ON)}$ )		0.4	$\Omega$ max	
		3	$\Omega$ typ	$V_S = 0\text{ V}$ to $V_{DD}$ , $I_{DS} = 10\text{ mA}$
<b>LEAKAGE CURRENTS</b>				
Source OFF Leakage $I_S$ (OFF)	$\pm 0.01$		nA typ	$V_{DD} = 3.3\text{ V}$ $V_S = 3\text{ V}/1\text{ V}$ , $V_D = 1\text{ V}/3\text{ V}$ ; Test Circuit 2
	$\pm 0.1$	$\pm 0.3$	nA max	
Channel ON Leakage $I_D$ , $I_S$ (ON)	$\pm 0.01$		nA typ	$V_S = V_D = 1\text{ V}$ or $3\text{ V}$ ; Test Circuit 3
	$\pm 0.1$	$\pm 0.5$	nA max	
<b>DIGITAL INPUTS</b>				
Input High Voltage, $V_{INH}$		2.0	V min	
Input Low Voltage, $V_{INL}$		0.4	V max	
Input Current $I_{INL}$ or $I_{INH}$	0.005		$\mu\text{A}$ typ	$V_{IN} = V_{INL}$ or $V_{INH}$
		$\pm 0.1$	$\mu\text{A}$ max	
$C_{IN}$ , Digital Input Capacitance	4		pF typ	
<b>DYNAMIC CHARACTERISTICS<sup>2</sup></b>				
$t_{ON}$	28		ns typ	$R_L = 300\ \Omega$ , $C_L = 35\text{ pF}$ ; $V_S = 2\text{ V}$ , Test Circuit 4
		55	ns max	
$t_{OFF}$	9		ns typ	$R_L = 300\ \Omega$ , $C_L = 35\text{ pF}$ ; $V_S = 2\text{ V}$ , Test Circuit 4
		16	ns max	
ADG733 $t_{ON}(\overline{EN})$	29		ns typ	$R_L = 300\ \Omega$ , $C_L = 35\text{ pF}$ ; $V_S = 2\text{ V}$ , Test Circuit 5
		60	ns max	
$t_{OFF}(\overline{EN})$	9		ns typ	$R_L = 300\ \Omega$ , $C_L = 35\text{ pF}$ ; $V_S = 2\text{ V}$ , Test Circuit 5
		16	ns max	
Break-Before-Make Time Delay, $t_D$	22		ns typ	$R_L = 300\ \Omega$ , $C_L = 35\text{ pF}$ ; $V_S = 2\text{ V}$ , Test Circuit 6
		1	ns min	
Charge Injection	$\pm 3$		pC typ	$V_S = 1\text{ V}$ , $R_S = 0\ \Omega$ , $C_L = 1\text{ nF}$ ; Test Circuit 7
Off Isolation	-62		dB typ	$R_L = 50\ \Omega$ , $C_L = 5\text{ pF}$ , $f = 10\text{ MHz}$ ; $R_L = 50\ \Omega$ , $C_L = 5\text{ pF}$ , $f = 1\text{ MHz}$ ; Test Circuit 8
	-82		dB typ	
Channel-to-Channel Crosstalk	-62		dB typ	$R_L = 50\ \Omega$ , $C_L = 5\text{ pF}$ , $f = 10\text{ MHz}$ ; $R_L = 50\ \Omega$ , $C_L = 5\text{ pF}$ , $f = 1\text{ MHz}$ ; Test Circuit 9
	-82		dB typ	
-3 dB Bandwidth	200		MHz typ	$R_L = 50\ \Omega$ , $C_L = 5\text{ pF}$ , Test Circuit 8
$C_S$ (OFF)	11		pF typ	
$C_D$ , $C_S$ (ON)	34		pF typ	
<b>POWER REQUIREMENTS</b>				
$I_{DD}$	0.001		$\mu\text{A}$ typ	$V_{DD} = 3.3\text{ V}$ Digital Inputs = 0 V or 3.3 V
		1.0	$\mu\text{A}$ max	

## NOTES

<sup>1</sup>Temperature ranges are as follows: B Version: -40°C to +85°C.<sup>2</sup>Guaranteed by design, not subject to production test.

Specifications subject to change without notice.

# ADG733/ADG734—SPECIFICATIONS<sup>1</sup>

**DUAL SUPPLY** ( $V_{DD} = +3\text{ V} \pm 10\%$ ,  $V_{SS} = -3\text{ V} \pm 10\%$ ,  $GND = 0\text{ V}$ , unless otherwise noted.)

Parameter	B Version		Unit	Test Conditions/Comments
	25°C	-40°C to +85°C		
<b>ANALOG SWITCH</b>				
Analog Signal Range		$V_{SS}$ to $V_{DD}$	V	
On Resistance ( $R_{ON}$ )	2.5		$\Omega$ typ	$V_S = V_{SS}$ to $V_{DD}$ , $I_{DS} = 10\text{ mA}$ ; Test Circuit 1
	4.5	5.0	$\Omega$ max	
On-Resistance Match between Channels ( $\Delta R_{ON}$ )		0.1	$\Omega$ typ	$V_S = V_{SS}$ to $V_{DD}$ , $I_{DS} = 10\text{ mA}$
		0.4	$\Omega$ max	
On-Resistance Flatness ( $R_{FLAT(ON)}$ )	0.5		$\Omega$ typ	$V_S = V_{SS}$ to $V_{DD}$ , $I_{DS} = 10\text{ mA}$
		1.2	$\Omega$ max	
<b>LEAKAGE CURRENTS</b>				
Source OFF Leakage $I_S$ (OFF)	$\pm 0.01$		nA typ	$V_{DD} = +3.3\text{ V}$ , $V_{SS} = -3.3\text{ V}$ $V_S = +2.25\text{ V}/-1.25\text{ V}$ , $V_D = -1.25\text{ V}/+2.25\text{ V}$ ; Test Circuit 2
	$\pm 0.1$	$\pm 0.3$	nA max	
Channel ON Leakage $I_D$ , $I_S$ (ON)	$\pm 0.01$		nA typ	$V_S = V_D = +2.25\text{ V}/-1.25\text{ V}$ , Test Circuit 3
	$\pm 0.1$	$\pm 0.5$	nA max	
<b>DIGITAL INPUTS</b>				
Input High Voltage, $V_{INH}$		2.0	V min	
Input Low Voltage, $V_{INL}$		0.4	V max	
Input Current				
$I_{INL}$ or $I_{INH}$	0.005		$\mu\text{A}$ typ	$V_{IN} = V_{INL}$ or $V_{INH}$
		$\pm 0.1$	$\mu\text{A}$ max	
$C_{IN}$ , Digital Input Capacitance	4		pF typ	
<b>DYNAMIC CHARACTERISTICS<sup>2</sup></b>				
$t_{ON}$	21		ns typ	$R_L = 300\ \Omega$ , $C_L = 35\text{ pF}$ ; $V_S = 1.5\text{ V}$ , Test Circuit 4
		35	ns max	
$t_{OFF}$	10		ns typ	$R_L = 300\ \Omega$ , $C_L = 35\text{ pF}$ ; $V_S = 1.5\text{ V}$ , Test Circuit 4
		16	ns max	
ADG733 $t_{ON}(\overline{EN})$	21		ns typ	$R_L = 300\ \Omega$ , $C_L = 35\text{ pF}$ ; $V_S = 1.5\text{ V}$ , Test Circuit 5
		40	ns max	
$t_{OFF}(\overline{EN})$	10		ns typ	$R_L = 300\ \Omega$ , $C_L = 35\text{ pF}$ ; $V_S = 1.5\text{ V}$ , Test Circuit 5
		16	ns max	
Break-Before-Make Time Delay, $t_D$	13		ns typ	$R_L = 300\ \Omega$ , $C_L = 35\text{ pF}$ ; $V_S = 1.5\text{ V}$ , Test Circuit 6
		1	ns min	
Charge Injection	$\pm 5$		pC typ	$V_S = 0\text{ V}$ , $R_S = 0\ \Omega$ , $C_L = 1\text{ nF}$ ; Test Circuit 7
Off Isolation	-62		dB typ	$R_L = 50\ \Omega$ , $C_L = 5\text{ pF}$ , $f = 10\text{ MHz}$ ; $R_L = 50\ \Omega$ , $C_L = 5\text{ pF}$ , $f = 1\text{ MHz}$ ; Test Circuit 8
	-82		dB typ	
Channel-to-Channel Crosstalk	-62		dB typ	$R_L = 50\ \Omega$ , $C_L = 5\text{ pF}$ , $f = 10\text{ MHz}$ ; $R_L = 50\ \Omega$ , $C_L = 5\text{ pF}$ , $f = 1\text{ MHz}$ ; Test Circuit 9
	-82		dB typ	
-3 dB Bandwidth	200		MHz typ	$R_L = 50\ \Omega$ , $C_L = 5\text{ pF}$ , Test Circuit 8
$C_S$ (OFF)	11		pF typ	
$C_D$ , $C_S$ (ON)	34		pF typ	
<b>POWER REQUIREMENTS</b>				
$I_{DD}$	0.001		$\mu\text{A}$ typ	$V_{DD} = 3.3\text{ V}$ Digital Inputs = 0 V or 3.3 V
		1.0	$\mu\text{A}$ max	
$I_{SS}$	0.001		$\mu\text{A}$ typ	$V_{SS} = -3.3\text{ V}$ Digital Inputs = 0 V or 3.3 V
		1.0	$\mu\text{A}$ max	

## NOTES

<sup>1</sup>Temperature range is as follows: B Version: -40°C to +85°C.

<sup>2</sup>Guaranteed by design, not subject to production test.

Specifications subject to change without notice.

## ABSOLUTE MAXIMUM RATINGS<sup>1</sup>

(T<sub>A</sub> = 25°C unless otherwise noted)

V <sub>DD</sub> to V <sub>SS</sub> .....	7 V
V <sub>DD</sub> to GND .....	-0.3 V to +7 V
V <sub>SS</sub> to GND .....	+0.3 V to -3.5 V
Analog Inputs <sup>2</sup> .....	V <sub>SS</sub> - 0.3 V to V <sub>DD</sub> + 0.3 V or 30 mA, Whichever Occurs First
Digital Inputs <sup>2</sup> .....	-0.3 V to V <sub>DD</sub> + 0.3 V or 30 mA, Whichever Occurs First
Peak Current, S or D .....	100 mA (Pulsed at 1 ms, 10% Duty Cycle max)
Continuous Current, S or D .....	30 mA
Operating Temperature Range	
Industrial (A, B Versions) .....	-40°C to +85°C
Storage Temperature Range .....	-65°C to +150°C

Junction Temperature .....	150°C
16-Lead TSSOP, θ <sub>JA</sub> Thermal Impedance .....	150.4°C/W
20-Lead TSSOP, θ <sub>JA</sub> Thermal Impedance .....	143°C/W
16-Lead QSOP, θ <sub>JA</sub> Thermal Impedance .....	149.97°C/W
Lead Temperature, Soldering (10 sec) .....	300°C
IR Reflow, Peak Temperature .....	220°C

### NOTES

<sup>1</sup>Stresses above those listed under Absolute Maximum Ratings may cause permanent damage to the device. This is a stress rating only; functional operation of the device at these or any other conditions above those listed in the operational sections of this specification is not implied. Exposure to absolute maximum rating conditions for extended periods may affect device reliability. Only one absolute maximum rating may be applied at any one time.

<sup>2</sup>Overvoltages at IN, S or D will be clamped by internal diodes. Current should be limited to the maximum ratings given.

## CAUTION

ESD (electrostatic discharge) sensitive device. Electrostatic charges as high as 4000 V readily accumulate on the human body and test equipment and can discharge without detection. Although the ADG733/ADG734 features proprietary ESD protection circuitry, permanent damage may occur on devices subjected to high-energy electrostatic discharges. Therefore, proper ESD precautions are recommended to avoid performance degradation or loss of functionality.



## ORDERING GUIDE

Model	Temperature Range	Package Description	Package Option
ADG733BRU	-40°C to +85°C	Thin Shrink Small Outline Package (TSSOP)	RU-16
ADG733BRQ	-40°C to +85°C	Quarter Size Outline Package (QSOP)	RQ-16
ADG734BRU	-40°C to +85°C	Thin Shrink Small Outline Package (TSSOP)	RU-20

## PIN CONFIGURATIONS

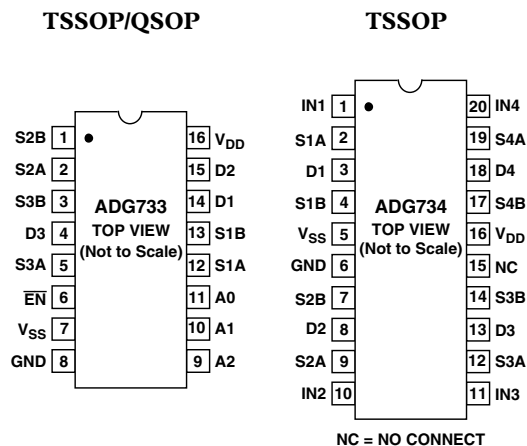

# ADG733/ADG734

**Table I. ADG733 Truth Table**

A2	A1	A0	$\overline{EN}$	ON Switch
X	X	X	1	None
0	0	0	0	D1-S1A, D2-S2A, D3-S3A
0	0	1	0	D1-S1B, D2-S2A, D3-S3A
0	1	0	0	D1-S1A, D2-S2B, D3-S3A
0	1	1	0	D1-S1B, D2-S2B, D3-S3A
1	0	0	0	D1-S1A, D2-S2A, D3-S3B
1	0	1	0	D1-S1B, D2-S2A, D3-S3B
1	1	0	0	D1-S1A, D2-S2B, D3-S3B
1	1	1	0	D1-S1B, D2-S2B, D3-S3B

X = Don't Care.

**Table II. ADG734 Truth Table**

Logic	Switch A	Switch B
0	OFF	ON
1	ON	OFF

## TERMINOLOGY

$V_{DD}$	Most Positive Power Supply Potential.	$C_{IN}$	Digital Input Capacitance.
$V_{SS}$	Most Negative Power Supply in a Dual Supply Application. In single supply applications, this should be tied to ground close to the device.	$t_{ON}$	Delay time measured between the 50% and 90% points of the digital inputs and the switch "ON" condition.
$I_{DD}$	Positive Supply Current.	$t_{OFF}$	Delay time measured between the 50% and 90% points of the digital input and the switch "OFF" condition.
$I_{SS}$	Negative Supply Current.	$t_{ON}(\overline{EN})$	Delay time between the 50% and 90% points of the $\overline{EN}$ digital input and the switch "ON" condition.
GND	Ground (0 V) Reference.	$t_{OFF}(\overline{EN})$	Delay time between the 50% and 90% points of the $\overline{EN}$ digital input and the switch "OFF" condition.
S	Source Terminal. May be an input or output.	$t_{OPEN}$	"OFF" time measured between the 80% points of both switches when switching from one address state to another.
D	Drain Terminal. May be an input or output.	Charge Injection	A measure of the glitch impulse transferred from the digital input to the analog output during switching.
IN	Logic Control Input.	Off Isolation	A measure of unwanted signal coupling through an "OFF" switch.
$V_D (V_S)$	Analog Voltage on Terminals D, S	Crosstalk	A measure of unwanted signal that is coupled through from one channel to another as a result of parasitic capacitance.
$R_{ON}$	Ohmic Resistance between D and S.	Bandwidth	The frequency at which the output is attenuated by 3 dBs.
$\Delta R_{ON}$	On Resistance Match between Any Two Channels, i.e., $R_{ONmax} - R_{ONmin}$	On Response	The Frequency Response of the "ON" Switch.
$R_{FLAT(ON)}$	Flatness is defined as the difference between the maximum and minimum value of on-resistance as measured over the specified analog signal range.	Insertion Loss	The loss due to the ON resistance of the switch.
$I_S (OFF)$	Source Leakage Current with the Switch "OFF."		
$I_D, I_S (ON)$	Channel Leakage Current with the Switch "ON."		
$V_{INL}$	Maximum Input Voltage for Logic "0."		
$V_{INH}$	Minimum Input Voltage for Logic "1."		
$I_{INL}(I_{INH})$	Input Current of the Digital Input.		
$C_S (OFF)$	"OFF" Switch Source Capacitance. Measured with reference to ground.		
$C_D, C_S(ON)$	"ON" Switch Capacitance. Measured with reference to ground.		

# Typical Performance Characteristics—ADG733/ADG734

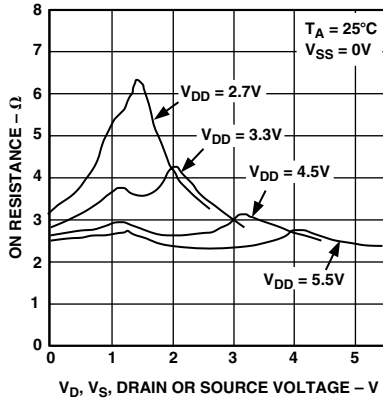

TPC 1. On Resistance as a Function of  $V_D$  ( $V_S$ ) for Single Supply

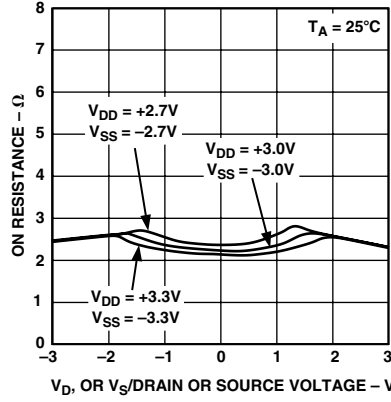

TPC 2. On Resistance as a Function of  $V_D$  ( $V_S$ ) for Dual Supply

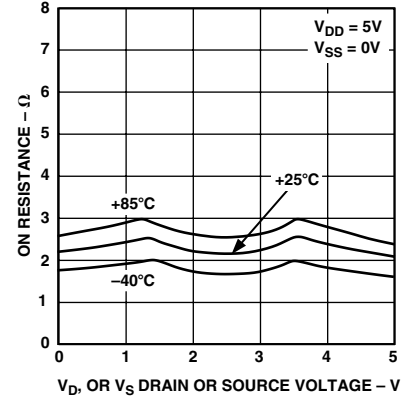

TPC 3. On Resistance as a Function of  $V_D$  ( $V_S$ ) for Different Temperatures, Single Supply

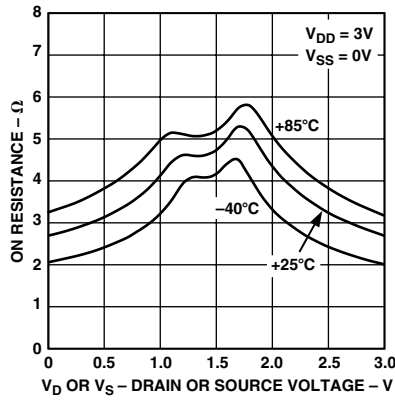

TPC 4. On Resistance as a Function of  $V_D$  ( $V_S$ ) for Different Temperatures, Single Supply

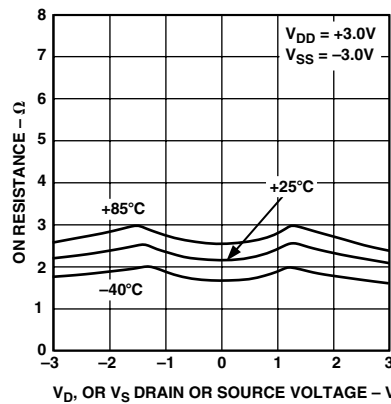

TPC 5. On Resistance as a Function of  $V_D$  ( $V_S$ ) for Different Temperatures, Dual Supply

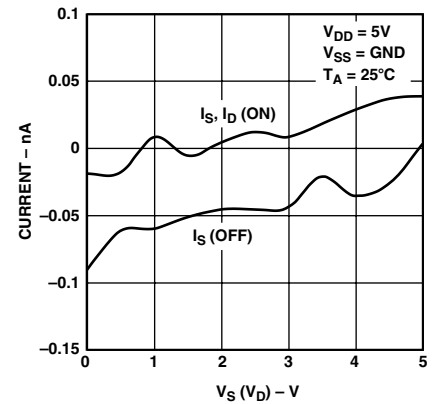

TPC 6. Leakage Currents as a Function of  $V_D$  ( $V_S$ )

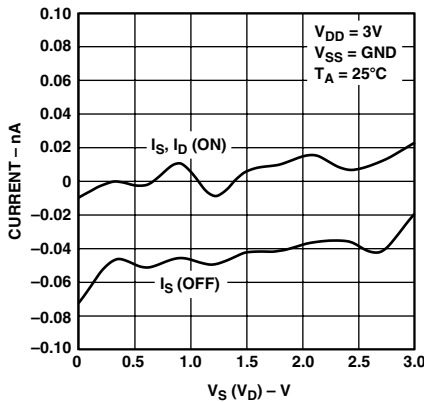

TPC 7. Leakage Currents as a Function of  $V_D$  ( $V_S$ )

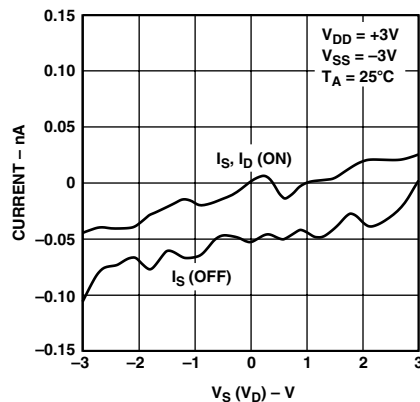

TPC 8. Leakage Currents as a Function of  $V_D$  ( $V_S$ )

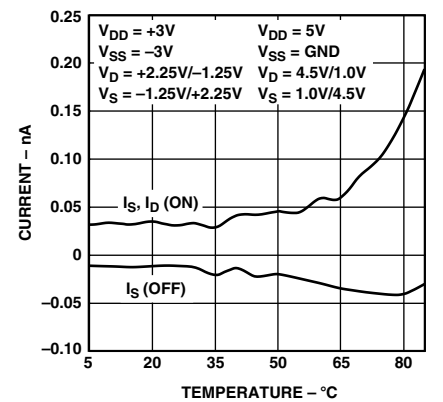

TPC 9. Leakage Currents as a Function of Temperature

# ADG733/ADG734

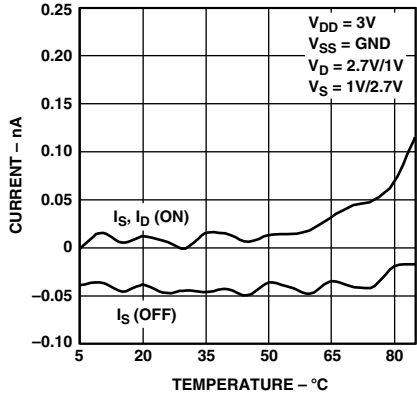

TPC 10. Leakage Currents as a Function of Temperature

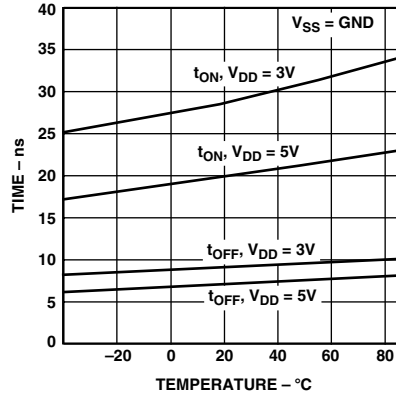

TPC 11.  $t_{ON}/t_{OFF}$  Times vs. Temperature

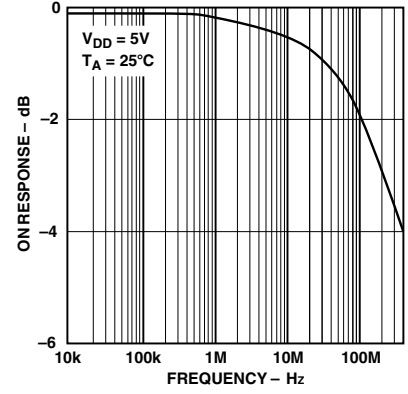

TPC 12. On Response vs. Frequency

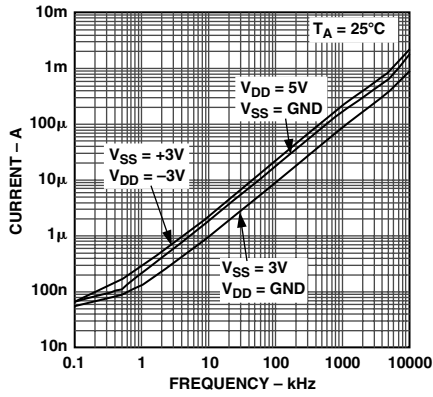

TPC 13. Input Current,  $I_{DD}$  vs. Switching Frequency

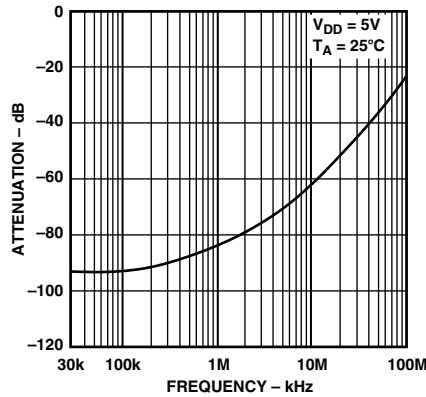

TPC 14. Off Isolation vs. Frequency

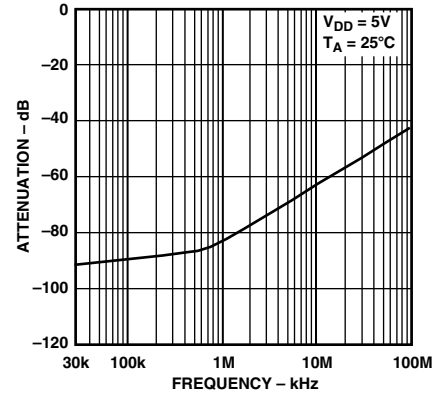

TPC 15. Crosstalk vs. Frequency

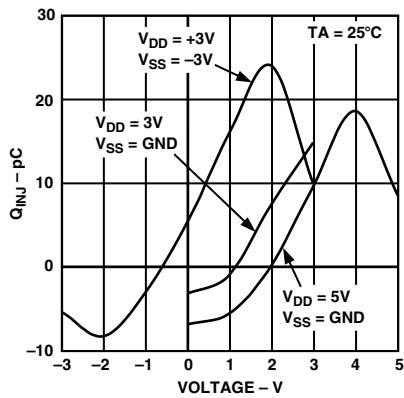

TPC 16. Charge Injection vs. Source Voltage

# Test Circuits

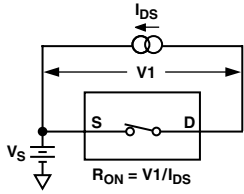

Test Circuit 1. On Resistance

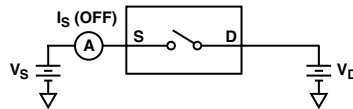

Test Circuit 2.  $I_S$  (OFF)

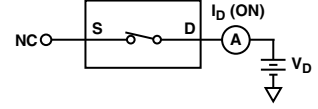

Test Circuit 3.  $I_D$  (ON)

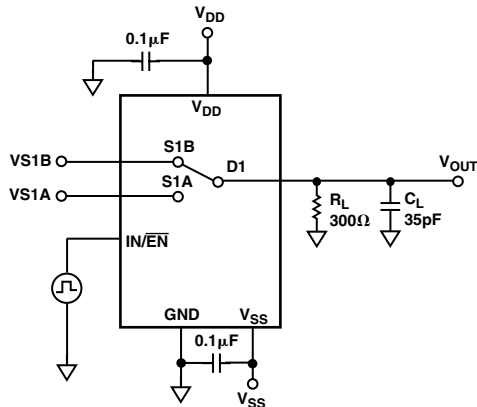

Test Circuit 4. Switching Times,  $t_{ON}$ ,  $t_{OFF}$

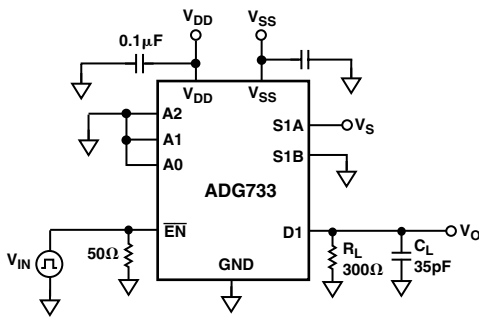

Test Circuit 5. Enable Delay,  $t_{ON}(\overline{EN})$ ,  $t_{OFF}(\overline{EN})$

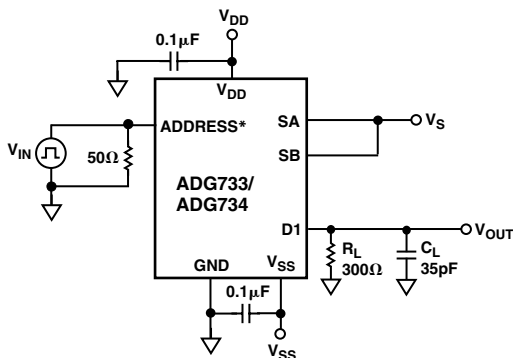

\*A0, A1, A2 FOR ADG733, IN1-4 FOR ADG734

Test Circuit 6. Break-Before-Make Delay,  $t_{OPEN}$

# ADG733/ADG734

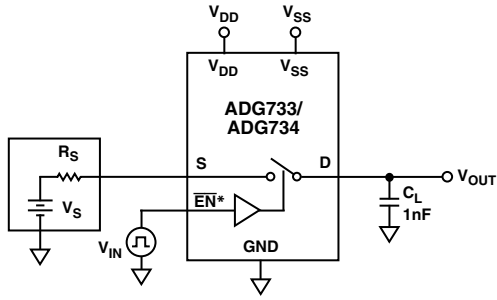

\* IN1-4 FOR ADG734

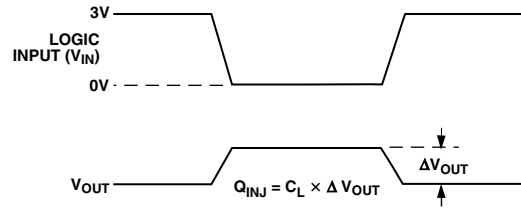

Test Circuit 7. Charge Injection

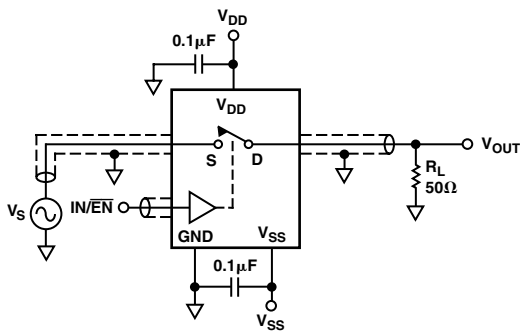

SWITCH OPEN FOR OFF ISOLATION MEASUREMENTS  
 SWITCH CLOSED FOR BANDWIDTH MEASUREMENTS  
 OFF ISOLATION =  $20 \text{LOG}_{10}(V_{\text{OUT}}/V_S)$

$$\text{INSERTION LOSS} = 20 \text{LOG}_{10} \left( \frac{V_{\text{OUT WITH SWITCH}}}{V_{\text{OUT WITHOUT SWITCH}}} \right)$$

Test Circuit 8. OFF Isolation and Bandwidth

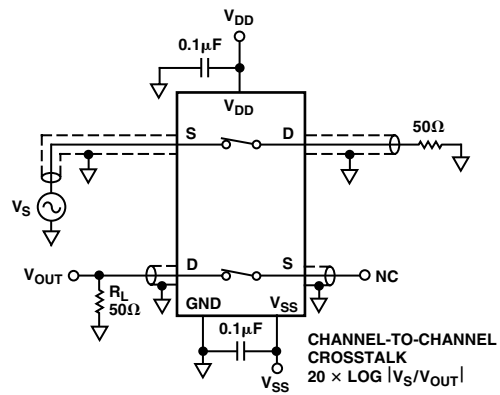

NC = NO CONNECT

CHANNEL-TO-CHANNEL  
 CROSSTALK  
 $20 \times \text{LOG} |V_S/V_{\text{OUT}}|$

Test Circuit 9. Channel-to-Channel Crosstalk

OUTLINE DIMENSIONS

Dimensions shown in inches and (mm).

16-Lead TSSOP  
(RU-16)

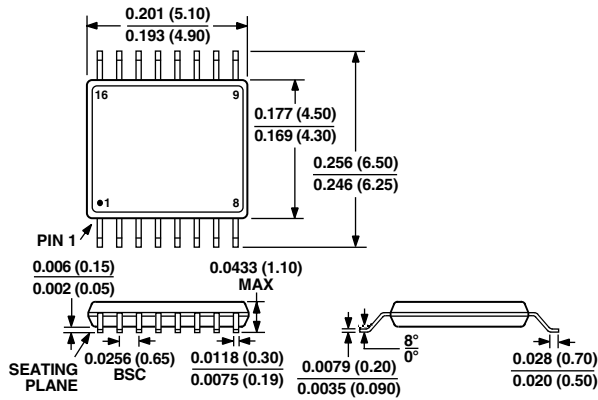

20-Lead TSSOP  
(RU-20)

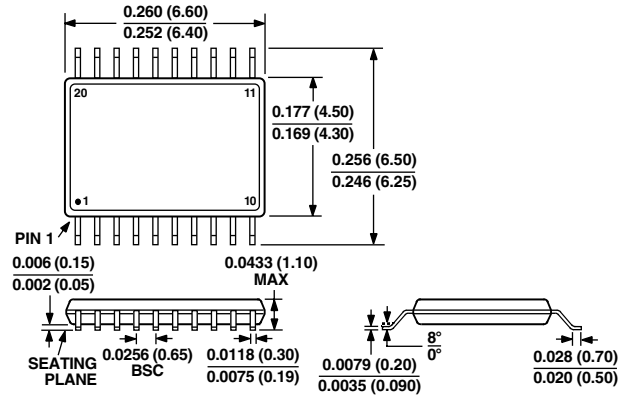

16-Lead QSOP  
(RQ-16)

