

FEATURES

44 V Supply Maximum Ratings
V_{SS} to V_{DD} Analog Signal Range
Low On Resistance (<35 Ω)
Ultralow Power Dissipation (<35 μW)
Fast Switching Times
 t_{ON} (160 ns max)
 t_{OFF} (100 ns max)
Break-Before-Make Switching Action
Plug-In Replacement for DG417

APPLICATIONS

Precision Test Equipment
Precision Instrumentation
Battery Powered Systems
Sample Hold Systems

GENERAL DESCRIPTION

The ADG417 is a monolithic CMOS SPST switch. This switch is designed on an enhanced LC²MOS process that provides low power dissipation yet gives high switching speed, low on resistance and low leakage currents.

The on resistance profile of the ADG417 is very flat over the full analog input range ensuring excellent linearity and low distortion. The part also exhibits high switching speed and high signal bandwidth. CMOS construction ensures ultralow power dissipation making the parts ideally suited for portable and battery powered instruments.

The ADG417 switch, which is turned ON with a logic low on the control input, conducts equally well in both directions when ON and has an input signal range that extends to the supplies. In the OFF condition, signal levels up to the supplies are blocked. The ADG417 exhibits break-before-make switching action for use in multiplexer applications. Inherent in the design is low charge injection for minimum transients when switching the digital input.

REV. A

Information furnished by Analog Devices is believed to be accurate and reliable. However, no responsibility is assumed by Analog Devices for its use, nor for any infringements of patents or other rights of third parties which may result from its use. No license is granted by implication or otherwise under any patent or patent rights of Analog Devices.

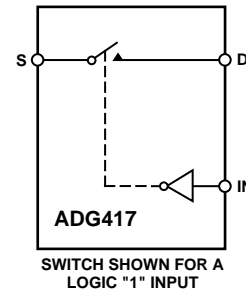
FUNCTIONAL BLOCK DIAGRAM**PRODUCT HIGHLIGHTS**

1. **Extended Signal Range**
The ADG417 is fabricated on an enhanced LC²MOS process, giving an increased signal range that extends to the supply rails.
2. **Ultralow Power Dissipation**
3. **Low R_{ON}**
4. **Single Supply Operation**
For applications where the analog signal is unipolar, the ADG417 can be operated from a single rail power supply. The part is fully specified with a single +12 V power supply and will remain functional with single supplies as low as +5 V.

ADG417—SPECIFICATIONS

Dual Supply¹ ($V_{DD} = +15\text{ V} \pm 10\%$, $V_{SS} = -15\text{ V} \pm 10\%$, $V_L = +5\text{ V} \pm 10\%$, $GND = 0\text{ V}$, unless otherwise noted)

Parameter	B Version		T Version		Units	Test Conditions/Comments
	+25°C	-40°C to +85°C	+25°C	-55°C to +125°C		
ANALOG SWITCH						
Analog Signal Range		V_{SS} to V_{DD}		V_{SS} to V_{DD}	V	
R_{ON}	25 35	45	25 35	45	Ω typ Ω max	$V_D = \pm 12.5\text{ V}$, $I_S = -10\text{ mA}$ $V_{DD} = +13.5\text{ V}$, $V_{SS} = -13.5\text{ V}$
LEAKAGE CURRENTS						
Source OFF Leakage I_S (OFF)	± 0.1 ± 0.25	± 5	± 0.1 ± 0.25	± 15	nA typ nA max	$V_{DD} = +16.5\text{ V}$, $V_{SS} = -16.5\text{ V}$ $V_D = \pm 15.5\text{ V}$, $V_S = \mp 15.5\text{ V}$; Test Circuit 2
Drain OFF Leakage I_D (OFF)	± 0.1 ± 0.25	± 5	± 0.1 ± 0.25	± 15	nA typ nA max	$V_D = \pm 15.5\text{ V}$, $V_S = \mp 15.5\text{ V}$; Test Circuit 2
Channel ON Leakage I_D , I_S (ON)	± 0.1 ± 0.4	± 5	± 0.1 ± 0.4	± 30	nA typ nA max	$V_S = V_D = \pm 15.5\text{ V}$; Test Circuit 3
DIGITAL INPUTS						
Input High Voltage, V_{INH}		2.4		2.4	V min	
Input Low Voltage, V_{INL}		0.8		0.8	V max	
Input Current I_{INL} or I_{INH}		± 0.005 ± 0.5		± 0.005 ± 0.5	μA typ μA max	$V_{IN} = V_{INL}$ or V_{INH}
DYNAMIC CHARACTERISTICS²						
t_{ON}	100 160	200	100 145	200	ns typ ns max	$R_L = 300\ \Omega$, $C_L = 35\text{ pF}$; $V_S = \pm 10\text{ V}$; Test Circuit 4
t_{OFF}	60 100	150	60 100	150	ns typ ns max	$R_L = 300\ \Omega$, $C_L = 35\text{ pF}$; $V_S = \pm 10\text{ V}$; Test Circuit 4
Charge Injection	7		7		pC typ	$V_S = 0\text{ V}$, $R_L = 0\ \Omega$, $C_L = 10\text{ nF}$; Test Circuit 5
OFF Isolation	80		80		dB typ	$R_L = 50\ \Omega$, $f = 1\text{ MHz}$; Test Circuit 6
C_S (OFF)	6		6		pF typ	
C_D (OFF)	6		6		pF typ	
C_D , C_S (ON)	55		55		pF typ	
POWER REQUIREMENTS						
I_{DD}	0.0001 1	2.5	0.0001 1	2.5	μA typ μA max	$V_{DD} = +16.5\text{ V}$, $V_{SS} = -16.5\text{ V}$ $V_{IN} = 0\text{ V}$ or 5 V
I_{SS}	0.0001 1	2.5	0.0001 1	2.5	μA typ μA max	
I_L	0.0001 1	2.5	0.0001 1	2.5	μA typ μA max	$V_L = +5.5\text{ V}$

NOTES

¹Temperature ranges are as follows: B Version: -40°C to $+85^\circ\text{C}$; T Version: -55°C to $+125^\circ\text{C}$.

²Guaranteed by design, not subject to production test.

Specifications subject to change without notice.

Single Supply¹ ($V_{DD} = +12\text{ V} \pm 10\%$, $V_{SS} = 0\text{ V}$, $V_L = +5\text{ V} \pm 10\%$, $GND = 0\text{ V}$, unless otherwise noted)

Parameter	B Version -40°C to		T Version -55°C to		Units	Test Conditions/Comments
	+25°C	+85°C	+25°C	+125°C		
ANALOG SWITCH						
Analog Signal Range		0 to V_{DD}		0 to V_{DD}	V	
R_{ON}	40	60	40	70	Ω typ Ω max	$V_D = +3\text{ V}$, $+8.5\text{ V}$, $I_S = -10\text{ mA}$ $V_{DD} = +10.8\text{ V}$
LEAKAGE CURRENT						
Source OFF Leakage I_S (OFF)	± 0.1	± 5	± 0.1	± 15	nA typ nA max	$V_{DD} = +13.2\text{ V}$ $V_D = 12.2\text{ V}/1\text{ V}$, $V_S = 1\text{ V}/12.2\text{ V}$; Test Circuit 2
Drain OFF Leakage I_D (OFF)	± 0.1	± 5	± 0.1	± 15	nA typ nA max	$V_D = 12.2\text{ V}/1\text{ V}$, $V_S = 1\text{ V}/12.2\text{ V}$; Test Circuit 2
Channel ON Leakage I_D , I_S (ON)	± 0.1	± 5	± 0.1	± 30	nA typ nA max	$V_S = V_D = 12.2\text{ V}/1\text{ V}$; Test Circuit 3
DIGITAL INPUTS						
Input High Voltage, V_{INH}		2.4		2.4	V min	
Input Low Voltage, V_{INL}		0.8		0.8	V max	
Input Current I_{INL} or I_{INH}		± 0.005 ± 0.5		± 0.005 ± 0.5	μA typ μA max	$V_{IN} = V_{INL}$ or V_{INH}
DYNAMIC CHARACTERISTICS ²						
t_{ON}	180	250	180	250	ns max	$R_L = 300\ \Omega$, $C_L = 35\text{ pF}$; $V_S = +8\text{ V}$; Test Circuit 4
t_{OFF}	85	110	85	110	ns max	$R_L = 300\ \Omega$, $C_L = 35\text{ pF}$; $V_S = +8\text{ V}$; Test Circuit 4
Charge Injection	11		11		pC typ	$V_S = 0\text{ V}$, $R_S = 0\ \Omega$, $C_L = 10\text{ nF}$; Test Circuit 5
OFF Isolation	80		80		dB typ	$R_L = 50\ \Omega$, $f = 1\text{ MHz}$; Test Circuit 6
C_S (OFF)	13		13		pF typ	
C_D (OFF)	13		13		pF typ	
C_D , C_S (ON)	65		65		pF typ	
POWER REQUIREMENTS						
I_{DD}	0.0001		0.0001		μA typ	$V_{DD} = +13.2\text{ V}$ $V_{IN} = 0\text{ V}$ or 5 V
I_L	1	2.5	1	2.5	μA max	
	0.0001		0.0001		μA typ	$V_L = +5.5\text{ V}$
	1	2.5	1	2.5	μA max	

NOTES

¹Temperature ranges are as follows: B Version: -40°C to +85°C; T Version: -55°C to +125°C.

²Guaranteed by design, not subject to production test.

Specifications subject to change without notice.

Table I. Truth Table

Logic	Switch Condition
0	ON
1	OFF

ORDERING GUIDE

Model	Temperature Range	Package Options*
ADG417BN	-40°C to +85°C	N-8
ADG417BR	-40°C to +85°C	SO-8

*N = Plastic DIP, SO = 0.15" Small Outline IC (SOIC).

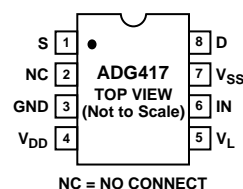
PIN CONFIGURATION
DIP/SOIC

ADG417

ABSOLUTE MAXIMUM RATINGS¹

(T_A = +25°C unless otherwise noted)

V _{DD} to V _{SS}	+44 V
V _{DD} to GND	-0.3 V to +25 V
V _{SS} to GND	+0.3 V to -25 V
V _L to GND	-0.3 V to V _{DD} + 0.3 V
Analog, Digital Inputs ²	V _{SS} - 2 V to V _{DD} + 2 V or 30 mA, Whichever Occurs First
Continuous Current, S or D	30 mA
Peak Current, S or D	100 mA
(Pulsed at 1 ms, 10% Duty Cycle Max)	
Operating Temperature Range	
Industrial (B Version)	-40°C to +85°C
Extended (T Version)	-55°C to +125°C
Storage Temperature Range	-65°C to +150°C
Junction Temperature	150°C

CAUTION

ESD (electrostatic discharge) sensitive device. Electrostatic charges as high as 4000 V readily accumulate on the human body and test equipment and can discharge without detection. Although the ADG417 features proprietary ESD protection circuitry, permanent damage may occur on devices subjected to high energy electrostatic discharges. Therefore, proper ESD precautions are recommended to avoid performance degradation or loss of functionality.



Plastic Package, Power Dissipation	400 mW
θ _{JA} , Thermal Impedance	100°C/W
Lead Temperature, Soldering (10 sec)	+260°C
SOIC Package, Power Dissipation	400 mW
θ _{JA} , Thermal Impedance	155°C/W
Lead Temperature, Soldering	
Vapor Phase (60 sec)	+215°C
Infrared (15 sec)	+220°C

NOTES

¹Stresses above those listed under Absolute Maximum Ratings may cause permanent damage to the device. This is a stress rating only; functional operation of the device at these or any other conditions above those listed in the operational sections of this specification is not implied. Exposure to absolute maximum rating conditions for extended periods may affect device reliability. Only one absolute maximum rating may be applied at any one time.

²Overvoltages at IN, S or D will be clamped by internal diodes. Current should be limited to the maximum ratings given.

TERMINOLOGY

V _{DD}	Most positive power supply potential.
V _{SS}	Most negative power supply potential in dual supplies. In single supply applications, it may be connected to GND.
V _L	Logic power supply (+5 V).
GND	Ground (0 V) reference.
S	Source terminal. May be an input or an output.
D	Drain terminal. May be an input or an output.
IN	Logic control input.
R _{ON}	Ohmic resistance between D and S.
I _S (OFF)	Source leakage current with the switch "OFF."
I _D (OFF)	Drain leakage current with the switch "OFF."
I _D , I _S (ON)	Channel leakage current with the switch "ON."

V _D (V _S)	Analog voltage on terminals D, S.
C _S (OFF)	"OFF" switch source capacitance.
C _D (OFF)	"OFF" switch drain capacitance.
C _D , C _S (ON)	"ON" switch capacitance.
t _{ON}	Delay between applying the digital control input and the output switching on.
t _{OFF}	Delay between applying the digital control input and the output switching off.
V _{INL}	Maximum input voltage for logic "0."
V _{INH}	Minimum input voltage for logic "1."
I _{INL} (I _{INH})	Input current of the digital input.
Charge Injection	A measure of the glitch impulse transferred from the digital input to the analog output during switching.
Off Isolation	A measure of unwanted signal coupling through an "OFF" channel.
I _{DD}	Positive supply current.
I _{SS}	Negative supply current.
I _L	Logic supply current.

Typical Performance Characteristics—ADG417

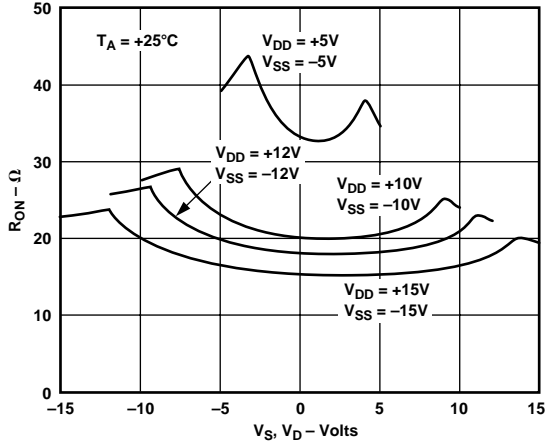

Figure 1. R_{ON} as a Function of V_D (V_S): Dual Supply Voltage

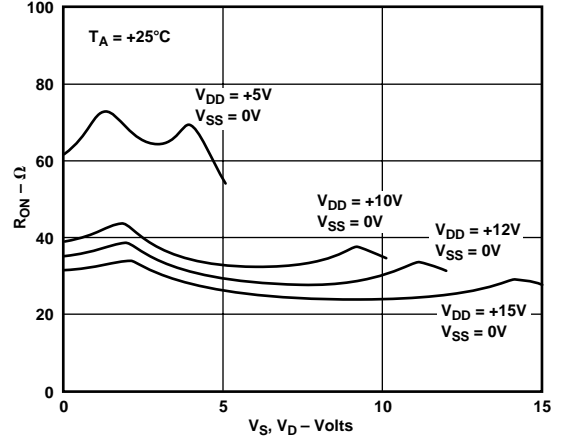

Figure 4. R_{ON} as a Function of V_D (V_S): Single Supply Voltage

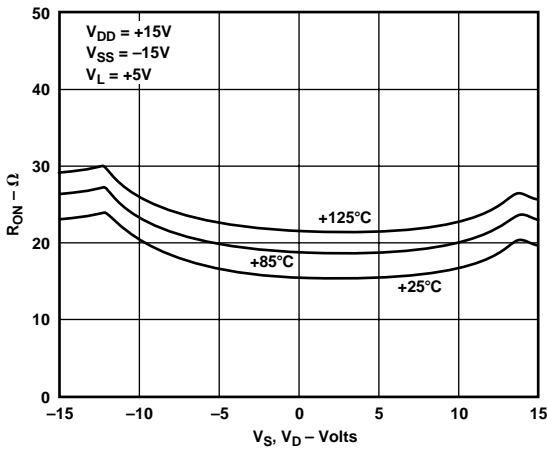

Figure 2. R_{ON} as a Function of V_D (V_S) for Different Temperatures

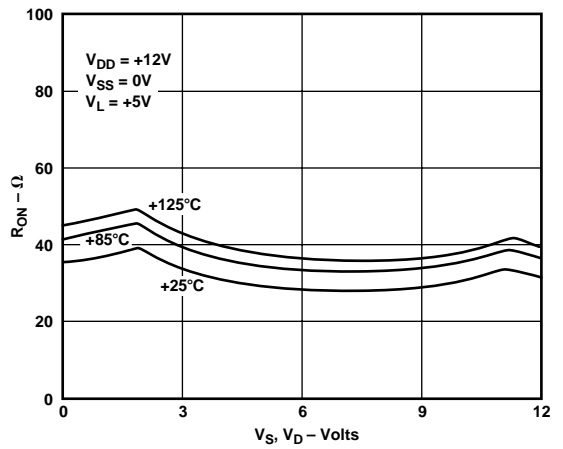

Figure 5. R_{ON} as a Function of V_D (V_S) for Different Temperatures

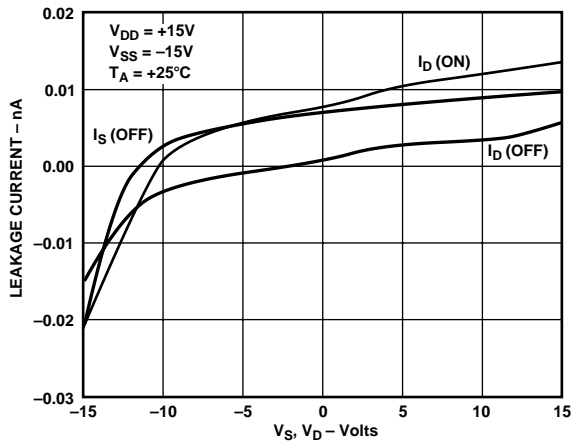

Figure 3. Leakage Currents as a Function of V_S (V_D)

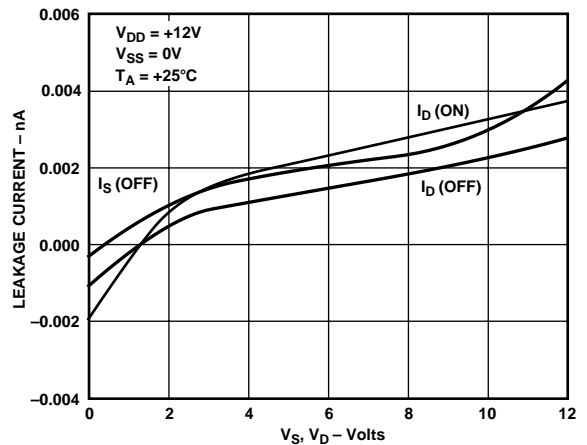

Figure 6. Leakage Currents as a Function of V_S (V_D)

ADG417

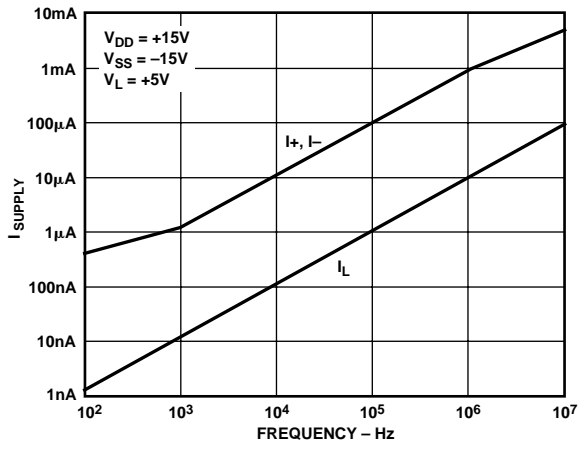

Figure 7. Supply Current vs. Input Switching Frequency

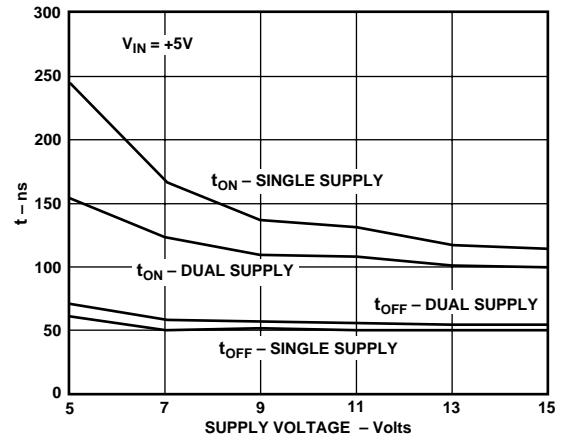
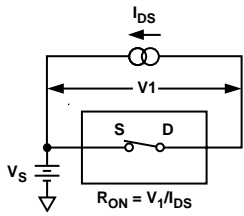
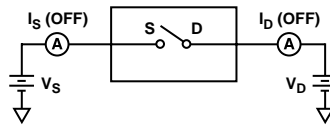

Figure 8. Switching Time vs. Power Supply

Test Circuits



Test Circuit 1. On Resistance



Test Circuit 2. Off Leakage

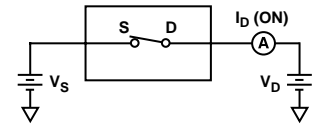

Test Circuit 3. On Leakage

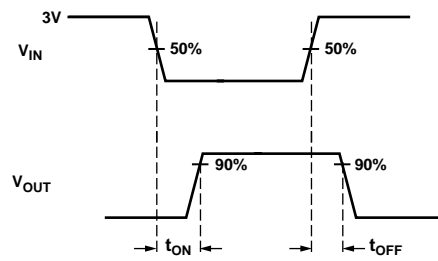
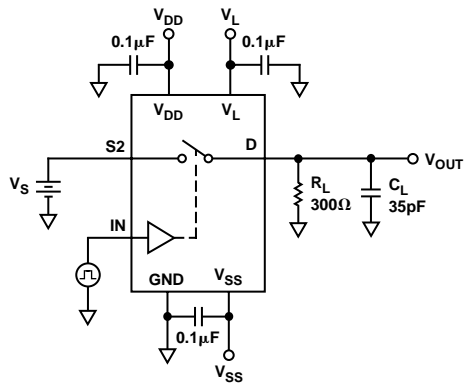

Test Circuit 4. Switching Times

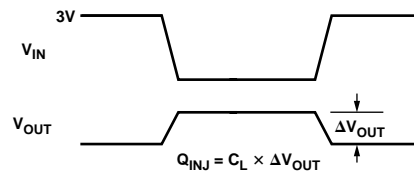
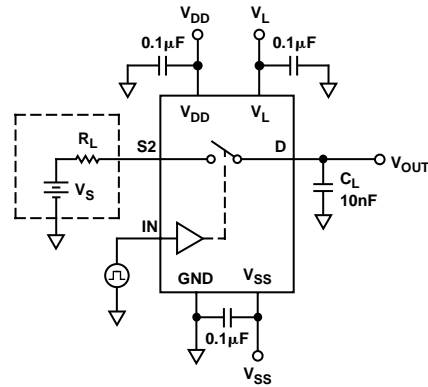

Test Circuit 5. Charge Injection

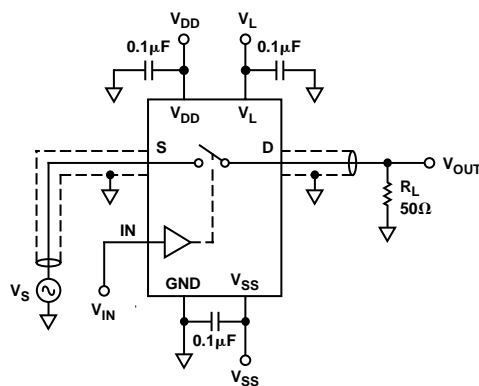

Test Circuit 6. Off Isolation

OUTLINE DIMENSIONS

Dimensions shown in inches and (mm).

8-Lead Plastic DIP (N-8)

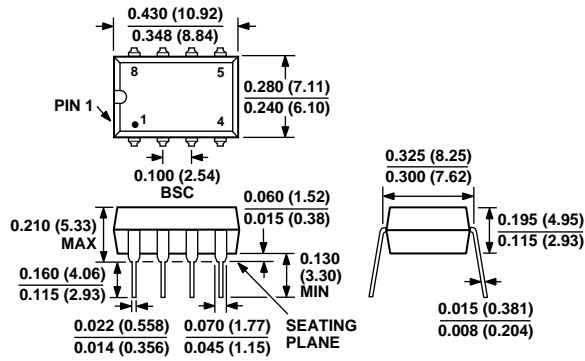

**8-Lead SOIC (SO-8)
(Narrow Body)**

