

FEATURES

14-Bit Dual Muxed Port DAC
300 MSPS Output Update Rate
Excellent SFDR and IMD Performance
SFDR to Nyquist @ 25 MHz Output: 71 dB
Internal Clock Doubling PLL
Differential or Single-Ended Clock Input
On-Chip 1.2 V Reference
Single 3.3 V Supply Operation
Power Dissipation: 155 mW @ 3.3 V
48-Lead LQFP

APPLICATIONS

Communications: LMDS, LMCS, MMDS
Base Stations
Digital Synthesis
QAM and OFDM

PRODUCT DESCRIPTION

The AD9755 is a dual, muxed port, ultrahigh-speed, single-channel, 14-bit CMOS DAC. It integrates a high-quality 14-bit TxDAC+ core, a voltage reference, and digital interface circuitry into a small 48-lead LQFP package. The AD9755 offers exceptional ac and dc performance while supporting update rates up to 300 MSPS.

The AD9755 has been optimized for ultrahigh-speed applications up to 300 MSPS where data rates exceed those possible on a single data interface port DAC. The digital interface consists of two buffered latches as well as control logic. These latches can be time multiplexed to the high-speed DAC in several ways. This PLL drives the DAC latch at twice the speed of the externally applied clock and is able to interleave the data from the two input channels. The resulting output data rate is twice that of the two input channels. With the PLL disabled, an external 2× clock may be supplied and divided by two internally.

The CLK inputs (CLK+/CLK-) can be driven either differentially or single-endedly, with a signal swing as low as 1 V p-p.

FUNCTIONAL BLOCK DIAGRAM

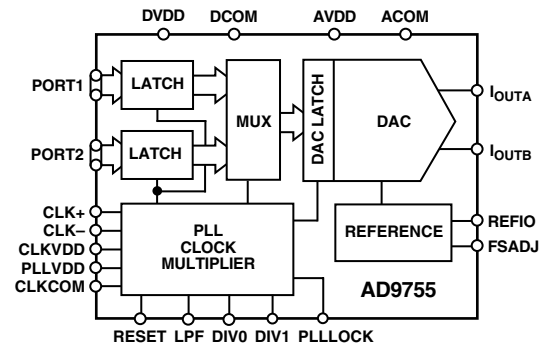

The DAC utilizes a segmented current source architecture combined with a proprietary switching technique to reduce glitch energy and to maximize dynamic accuracy. Differential current outputs support single-ended or differential applications. The differential outputs each provide a nominal full-scale current from 2 mA to 20 mA.

The AD9755 is manufactured on an advanced low cost 0.35 μm CMOS process. It operates from a single supply of 3.1 V to 3.5 V and consumes 155 mW of power.

PRODUCT HIGHLIGHTS

1. The AD9755 is a member of a pin-compatible family of high-speed TxDAC+s providing 10-, 12-, and 14-bit resolution.
2. Ultrahigh-Speed 300 MSPS Conversion Rate.
3. Dual 14-Bit Latched, Multiplexed Input Ports. The AD9755 features a flexible digital interface allowing high-speed data conversion through either a single or dual port input.
4. Low Power. Complete CMOS DAC function operates on 155 mW from a 3.1 V to 3.5 V single supply. The DAC full-scale current can be reduced for lower power operation.
5. On-Chip Voltage Reference. The AD9755 includes a 1.20 V temperature-compensated bandgap voltage reference.

TxDAC+ is a registered trademark of Analog Devices, Inc.

*Protected by U.S. Patent numbers 5450084, 5568145, 5689257 and 5703519. Other patents pending.

REV. 0

Information furnished by Analog Devices is believed to be accurate and reliable. However, no responsibility is assumed by Analog Devices for its use, nor for any infringements of patents or other rights of third parties which may result from its use. No license is granted by implication or otherwise under any patent or patent rights of Analog Devices.

AD9755—SPECIFICATIONS

DC SPECIFICATIONS (T_{MIN} to T_{MAX} , AVDD = 3.3 V, DVDD = 3.3 V, PLLVDD = 3.3 V, CLKVDD = 3.3 V, I_{OUTFS} = 20 mA, unless otherwise noted.)

| Parameter | Min | Typ | Max | Unit |
|---|--------|-------|--------|---------------|
| RESOLUTION | 14 | | | Bits |
| DC ACCURACY ¹ | | | | |
| Integral Linearity Error (INL) | -5 | ±2.5 | +5 | LSB |
| Differential Nonlinearity (DNL) | -3 | ±1.5 | +3 | LSB |
| ANALOG OUTPUT | | | | |
| Offset Error | -0.025 | ±0.01 | +0.025 | % of FSR |
| Gain Error (Without Internal Reference) | -2 | ±0.5 | +2 | % of FSR |
| Gain Error (With Internal Reference) | -2 | ±0.25 | +2 | % of FSR |
| Full-Scale Output Current ² | 2.0 | | 20.0 | mA |
| Output Compliance Range | -1.0 | | +1.25 | V |
| Output Resistance | | 100 | | kΩ |
| Output Capacitance | | 5 | | pF |
| REFERENCE OUTPUT | | | | |
| Reference Voltage | 1.14 | 1.20 | 1.26 | V |
| Reference Output Current ³ | | 100 | | nA |
| REFERENCE INPUT | | | | |
| Input Compliance Range | 0.1 | | 1.25 | V |
| Reference Input Resistance | | 1 | | MΩ |
| TEMPERATURE COEFFICIENTS | | | | |
| Offset Drift | | 0 | | ppm of FSR/°C |
| Gain Drift (Without Internal Reference) | | ±50 | | ppm of FSR/°C |
| Gain Drift (With Internal Reference) | | ±100 | | ppm of FSR/°C |
| Reference Voltage Drift | | ±50 | | ppm/°C |
| POWER SUPPLY | | | | |
| Supply Voltages | | | | |
| AVDD | 3.0 | 3.3 | 3.6 | V |
| DVDD | 3.0 | 3.3 | 3.6 | V |
| PLLVDD | 3.0 | 3.3 | 3.6 | V |
| CLKVDD | 3.0 | 3.3 | 3.6 | V |
| Analog Supply Current (I_{AVDD}) ⁴ | | 33 | 36 | mA |
| Digital Supply Current (I_{DVDD}) ⁴ | | 3.5 | 4.5 | mA |
| PLL Supply Current (I_{PLLVDD}) ⁴ | | 4.5 | 5.1 | mA |
| Clock Supply Current (I_{CLKVDD}) ⁴ | | 10.0 | 11.5 | mA |
| Power Dissipation ⁴ (3 V, I_{OUTFS} = 20 mA) | | 155 | 165 | mW |
| Power Dissipation ⁵ (3 V, I_{OUTFS} = 20 mA) | | 216 | | mW |
| Power Supply Rejection Ratio ⁶ —AVDD | -1 | | +1 | % of FSR/V |
| Power Supply Rejection Ratio ⁶ —DVDD | -0.04 | | +0.04 | % of FSR/V |
| OPERATING RANGE | -40 | | +85 | °C |

NOTES

¹Measured at I_{OUTA} , driving a virtual ground.

²Nominal full-scale current, I_{OUTFS} , is 32× the I_{REF} current.

³An external buffer amplifier is recommended to drive any external load.

⁴100 MSPS f_{DAC} with PLL on, f_{OUT} = 100 MHz, all supplies = 3.0 V.

⁵300 MSPS f_{DAC} .

⁶±5% power supply variation.

Specifications subject to change without notice.

DYNAMIC SPECIFICATIONS

(T_{MIN} to T_{MAX} , AVDD = 3.3 V, DVDD = 3.3 V, PLLVDD = 0 V, CLKVDD = 3.3 V, $I_{OUTFS} = 20$ mA,
Differential Transformer Coupled Output, 50 Ω Doubly Terminated, unless otherwise noted.)

| Parameter | Min | Typ | Max | Unit | | | | |
|--|------|-----|-----|-----------------|--|-----|-----|-----|
| DYNAMIC PERFORMANCE | | | | | | | | |
| Maximum Output Update Rate (f_{DAC}) | 300 | | | MSPS | | | | |
| Output Settling Time (t_{ST}) (to 0.1%) ¹ | | 11 | | ns | | | | |
| Output Propagation Delay (t_{PD}) ¹ | | 1 | | ns | | | | |
| Glitch Impulse ¹ | | 5 | | pV-s | | | | |
| Output Rise Time (10% to 90%) ¹ | | 2.5 | | ns | | | | |
| Output Fall Time (90% to 10%) ¹ | | 2.5 | | ns | | | | |
| Output Noise ($I_{OUTFS} = 20$ mA) | | 50 | | pA/ \sqrt{Hz} | | | | |
| Output Noise ($I_{OUTFS} = 2$ mA) | | 30 | | pA/ \sqrt{Hz} | | | | |
| AC LINEARITY | | | | | | | | |
| Spurious-Free Dynamic Range to Nyquist | | | | | | | | |
| $f_{DAC} = 100$ MSPS; $f_{OUT} = 1.00$ MHz | 74 | 84 | | dBc | | | | |
| 0 dBFS Output | | | | | | | | |
| -6 dBFS Output | | | | | | | | |
| -12 dBFS Output | | | | | | | | |
| $f_{DATA} = 65$ MSPS; $f_{OUT} = 1.1$ MHz ² | | | | | | | | |
| $f_{DATA} = 65$ MSPS; $f_{OUT} = 5.1$ MHz ² | | | | | | | | |
| $f_{DATA} = 65$ MSPS; $f_{OUT} = 10.1$ MHz ² | | | | | | | | |
| $f_{DATA} = 65$ MSPS; $f_{OUT} = 20.1$ MHz ² | | | | | | | | |
| $f_{DATA} = 65$ MSPS; $f_{OUT} = 30.1$ MHz ² | | | | | | | | |
| $f_{DAC} = 160$ MSPS; $f_{OUT} = 1.1$ MHz | | | | | | | | |
| $f_{DAC} = 160$ MSPS; $f_{OUT} = 11.1$ MHz | | | | | | | | |
| $f_{DAC} = 160$ MSPS; $f_{OUT} = 31.1$ MHz | | | | | | | | |
| $f_{DAC} = 160$ MSPS; $f_{OUT} = 51.1$ MHz | | | | | | | | |
| $f_{DAC} = 160$ MSPS; $f_{OUT} = 71.1$ MHz | | | | | | | | |
| $f_{DAC} = 300$ MSPS; $f_{OUT} = 1.1$ MHz | 83.5 | 93 | | dBc | | | | |
| $f_{DAC} = 300$ MSPS; $f_{OUT} = 26.1$ MHz | | | | | | | | |
| $f_{DAC} = 300$ MSPS; $f_{OUT} = 51.1$ MHz | | | | | | | | |
| $f_{DAC} = 300$ MSPS; $f_{OUT} = 101.1$ MHz | | | | | | | | |
| $f_{DAC} = 300$ MSPS; $f_{OUT} = 141.1$ MHz | | | | | | | | |
| Spurious-Free Dynamic Range within a Window | | | | | | | | |
| $f_{DAC} = 100$ MSPS; $f_{OUT} = 1$ MHz; 2 MHz Span | | | | | | | | |
| 0 dBFS Output | | | | | | | | |
| $f_{DAC} = 65$ MSPS; $f_{OUT} = 5.02$ MHz; 2 MHz Span | | | | | | | | |
| $f_{DAC} = 150$ MSPS; $f_{OUT} = 5.04$ MHz; 4 MHz Span | | | | | | | | |
| Total Harmonic Distortion | | | | | | | | |
| $f_{DAC} = 100$ MSPS; $f_{OUT} = 1.00$ MHz | | | | | | | | |
| $T_A = 25^\circ C$ | | | | | | -83 | -73 | dBc |
| T_{MIN} to T_{MAX} | | -83 | -71 | dBc | | | | |
| $f_{DAC} = 65$ MHz; $f_{OUT} = 2.00$ MHz | | -78 | | dBc | | | | |
| $f_{DAC} = 160$ MHz; $f_{OUT} = 2.00$ MHz | | -78 | | dBc | | | | |
| Multitone Power Ratio (Eight Tones at 110 kHz Spacing) | | | | | | | | |
| $f_{DAC} = 65$ MSPS; $f_{OUT} = 2.00$ MHz to 2.77 MHz | | | | | | | | |
| 0 dBFS Output | | 75 | | dBc | | | | |
| -6 dBFS Output | | 73 | | dBc | | | | |
| -12 dBFS Output | | 70 | | dBc | | | | |

NOTES

¹Measured single-ended into 50 Ω load.

²Single-Port Mode (PLL disabled, DIV0 = 1, DIV1 = 0, data on Port 1).

Specifications subject to change without notice.

AD9755—SPECIFICATIONS

DIGITAL SPECIFICATIONS

(T_{MIN} to T_{MAX} , $AVDD = 3.3$ V, $DVDD = 3.3$ V, $PLLVD = 3.3$ V, $CLKVDD = 3.3$ V, $I_{OUTFS} = 20$ mA, unless otherwise noted.)

| Parameter | Min | Typ | Max | Unit |
|--|-----|------|------|---------|
| DIGITAL INPUTS | | | | |
| Logic “1” | 2.1 | 3.3 | | V |
| Logic “0” | | 0 | 0.9 | V |
| Logic “1” Current | -10 | | +10 | μ A |
| Logic “0” Current | -10 | | +10 | μ A |
| Input Capacitance | | 5 | | pF |
| Input Setup Time (t_s) | | 0.5 | 1.0 | ns |
| Input Hold Time (t_H) | | 0.5 | 1.0 | ns |
| Input Setup Time (t_s , PLLVDD = 0 V) | | -1.5 | -1.0 | ns |
| Input Hold Time (t_H , PLLVDD = 0 V) | | 1.7 | 2.5 | ns |
| Min CLK Frequency ¹ | | 6.25 | | MHz |

NOTE

¹Min CLK freq only applies when using internal PLL. When PLL is disabled, there is no minimum CLK frequency.

ABSOLUTE MAXIMUM RATINGS*

| Parameter | With Respect to | Min | Max | Unit |
|-----------------------------------|----------------------------|------|--------------|--------------|
| AVDD, DVDD, CLKVDD, PLLVDD | ACOM, DCOM, CLKCOM, PLLCOM | -0.3 | +3.9 | V |
| AVDD, DVDD, CLKVDD, PLLVDD | ACOM, DCOM, CLKCOM, PLLCOM | -3.9 | +3.9 | V |
| ACOM, DCOM, CLKCOM, PLLCOM | ACOM, DCOM, CLKCOM, PLLCOM | -0.3 | +3.9 | V |
| REFIO, REFLO, FSADJ | ACOM | -0.3 | AVDD + 0.3 | V |
| I_{OUTA} , I_{OUTB} | ACOM | -1.0 | AVDD + 0.3 | V |
| Digital Data Inputs (DB13 to DB0) | DCOM | -0.3 | DVDD + 0.3 | V |
| CLK+/CLK-, PLLLOCK | CLKCOM | -0.3 | CLKVDD + 0.3 | V |
| DIV0, DIV1, RESET | CLKCOM | -0.3 | CLKVDD + 0.3 | V |
| LPF | PLLCOM | -0.3 | PLLVDD + 0.3 | V |
| Junction Temperature | | | 150 | $^{\circ}$ C |
| Storage Temperature | | -65 | +150 | $^{\circ}$ C |
| Lead Temperature (10 sec) | | | 300 | $^{\circ}$ C |

*Stresses above those listed under Absolute Maximum Ratings may cause permanent damage to the device. This is a stress rating only; functional operation of the device at these or any other conditions above those indicated in the operational sections of this specification is not implied. Exposure to absolute maximum ratings for extended periods may affect device reliability.

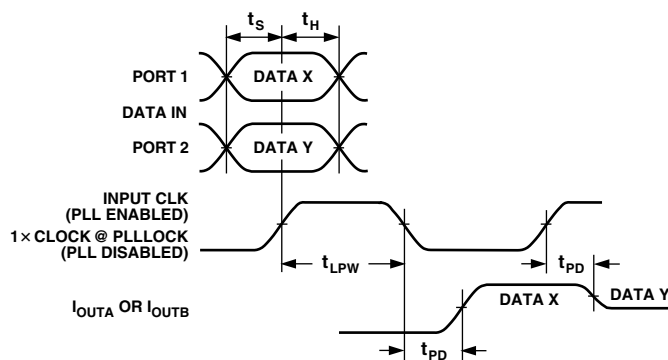

Figure 1. I/O Timing

ORDERING GUIDE

| Model | Temperature Range | Package Description | Package Option |
|-----------|--------------------------------------|---------------------|------------------|
| AD9755AST | -40 $^{\circ}$ C to +85 $^{\circ}$ C | 48-Lead LQFP | ST-48 |
| AD9755-EB | | | Evaluation Board |

THERMAL CHARACTERISTIC

Thermal Resistance

48-Lead LQFP

$$\theta_{JA} = 91^{\circ}\text{C/W}$$

CAUTION

ESD (electrostatic discharge) sensitive device. Electrostatic charges as high as 4000 V readily accumulate on the human body and test equipment and can discharge without detection. Although the AD9755 features proprietary ESD protection circuitry, permanent damage may occur on devices subjected to high-energy electrostatic discharges. Therefore, proper ESD precautions are recommended to avoid performance degradation or loss of functionality.



PIN FUNCTION DESCRIPTIONS

| Pin No. | Mnemonic | Description |
|---------|-------------------|---|
| 1 | RESET | Internal Clock Divider Reset |
| 2 | CLK+ | Differential Clock Input |
| 3 | CLK- | Differential Clock Input |
| 4, 22 | DCOM | Digital Common |
| 5, 21 | DVDD | Digital Supply Voltage |
| 6 | PLLLOCK | PLL Lock Indicator Output |
| 7–20 | P1B13–P1B0 | Data Bits P1B13 to P1B0, Port 1 |
| 23–36 | P2B13–P2B0 | Data Bits P2B13 to P2B0, Port 2 |
| 37, 38 | DIV0, DIV1 | Control inputs for PLL and input port selector mode, see Tables I and II for details. |
| 39 | REFIO | Reference Input/Output |
| 40 | FSADJ | Full-Scale Current Output Adjust |
| 41 | AVDD | Analog Supply Voltage |
| 42 | I _{OUTB} | Differential DAC Current Output |
| 43 | I _{OUTA} | Differential DAC Current Output |
| 44 | ACOM | Analog Common |
| 45 | CLKCOM | Clock and Phase-Locked Loop Common |
| 46 | LPF | PLL Loop Filter |
| 47 | PLLVDD | Phase-Locked Loop Supply Voltage |
| 48 | CLKVDD | Clock Supply Voltage |

PIN CONFIGURATION

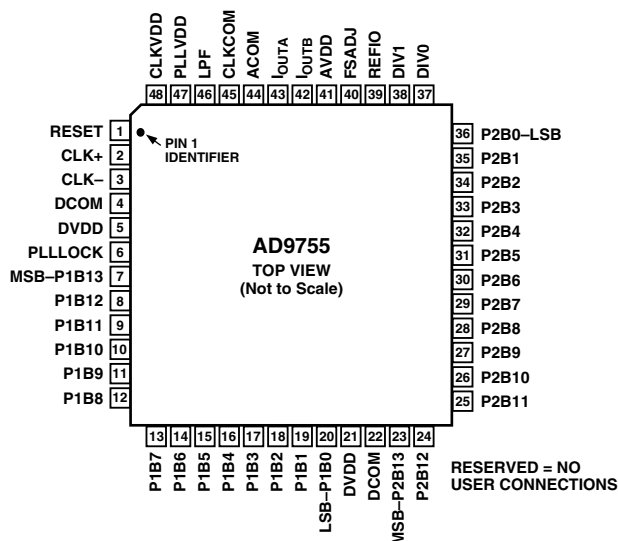

Typical Performance Characteristics—AD9755

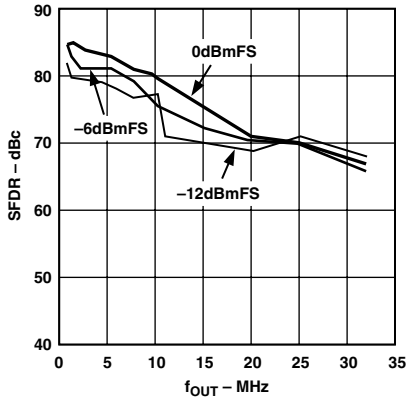

TPC 1. Single-Tone SFDR vs. f_{OUT} @ $f_{DAC} = 65$ MSPS; Single Port Mode

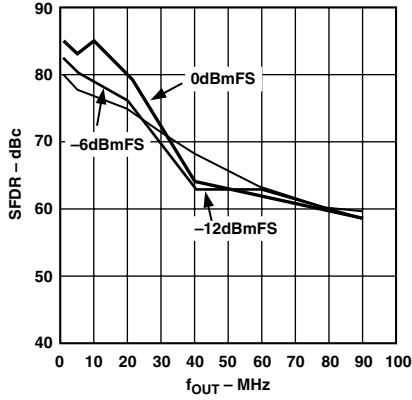

TPC 2. Single-Tone SFDR vs. f_{OUT} @ $f_{DAC} = 200$ MSPS

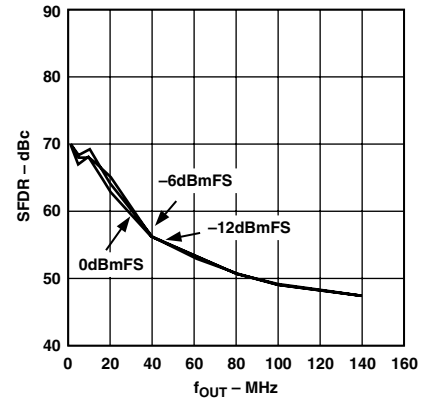

TPC 3. Single-Tone SFDR vs. f_{OUT} @ $f_{DAC} = 300$ MSPS

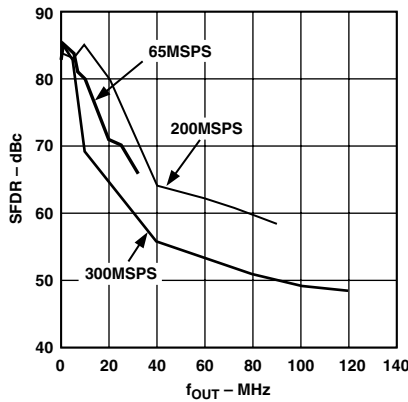

TPC 4. SFDR vs. f_{OUT} @ 0 dBFS

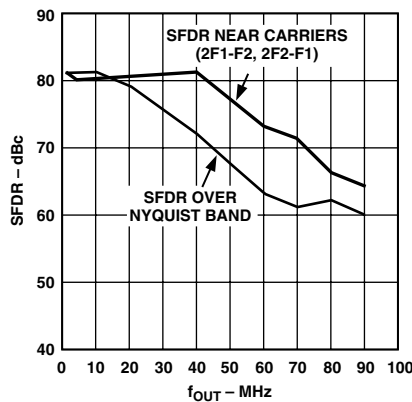

TPC 5. Two-Tone IMD vs. f_{OUT} @ $f_{DAC} = 200$ MSPS, 1 MHz Spacing between Tones, 0 dBFS

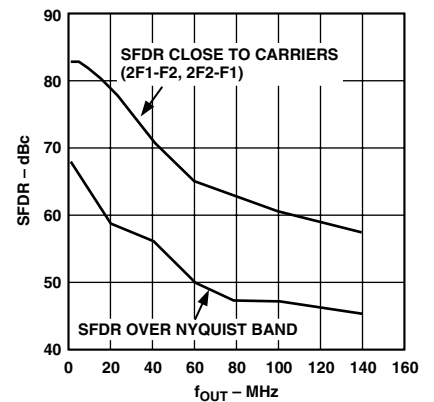

TPC 6. Two-Tone IMD vs. f_{OUT} @ $f_{DAC} = 300$ MSPS, 1 MHz Spacing between Tones, 0 dBFS

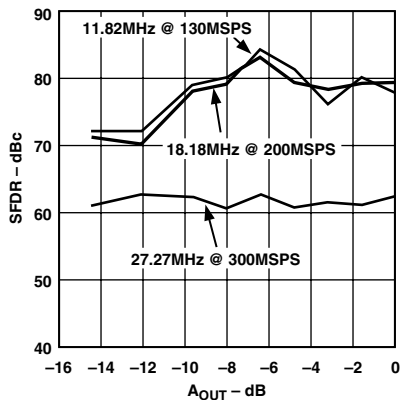

TPC 7. Single-Tone SFDR vs. A_{OUT} @ $f_{OUT} = f_{DAC}/11$

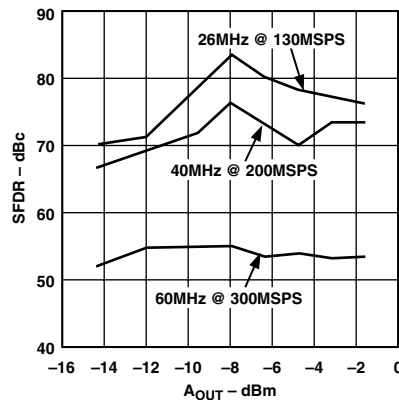

TPC 8. Single-Tone SFDR vs. A_{OUT} @ $f_{OUT} = f_{DAC}/5$

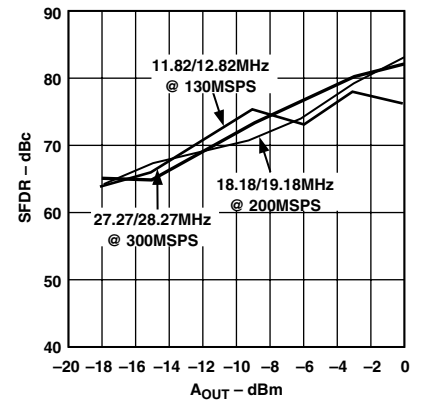

TPC 9. Two-Tone IMD (Third Order Products) vs. A_{OUT} @ $f_{OUT} = f_{DAC}/11$

AD9755

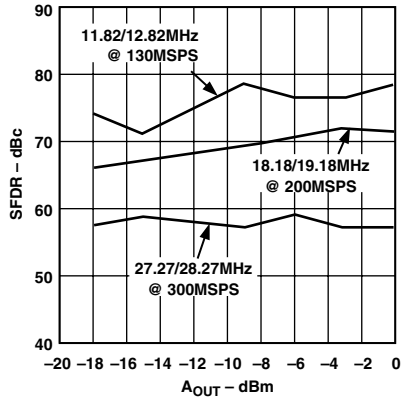

TPC 10. Two-Tone IMD (to Nyquist) vs. A_{OUT} @ $f_{OUT} = f_{DAC}/11$

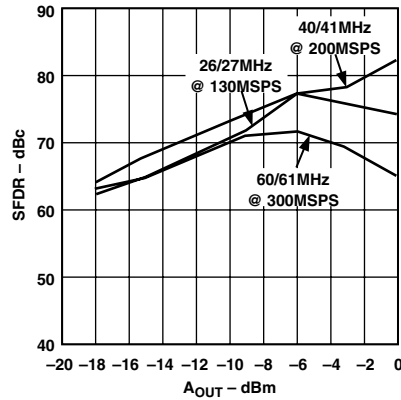

TPC 11. Two-Tone IMD (Third Order Products) vs. A_{OUT} @ $f_{OUT} = f_{DAC}/5$

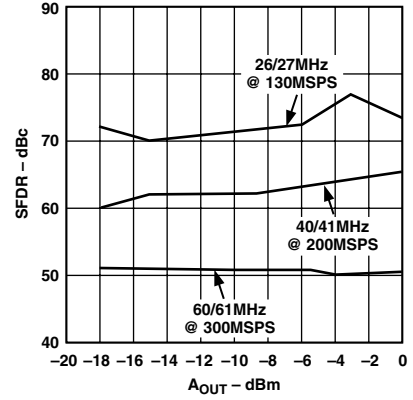

TPC 12. Two-Tone IMD (to Nyquist) vs. A_{OUT} @ $f_{OUT} = f_{DAC}/5$

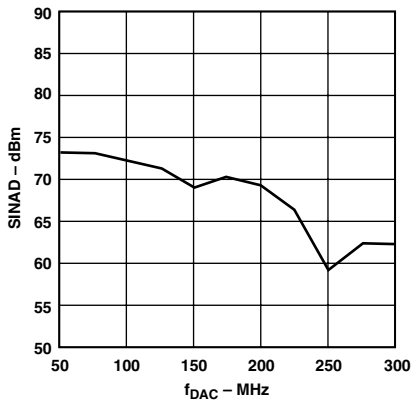

TPC 13. SINAD vs. f_{DAC} @ $f_{OUT} = 10$ MHz, 0 dBFS

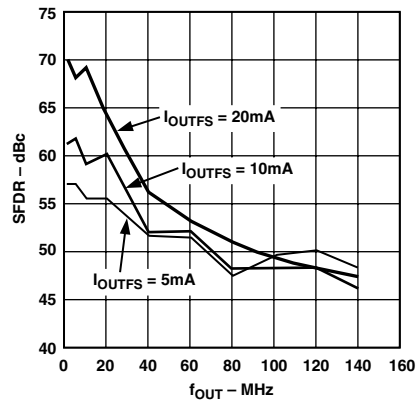

TPC 14. SFDR vs. I_{OUTFS} , $f_{DAC} = 300$ MSPS @ 0 dBFS

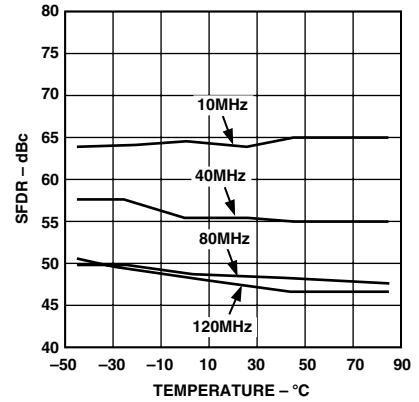

TPC 15. SFDR vs. Temperature, $f_{DAC} = 300$ MSPS @ 0 dBFS

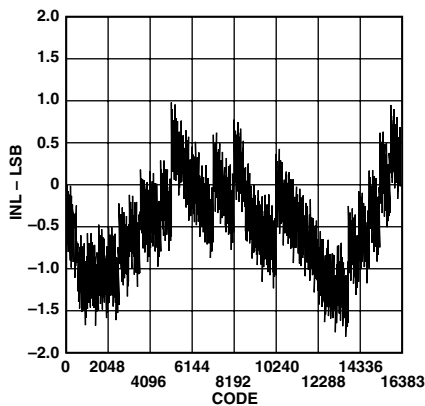

TPC 16. Typical INL

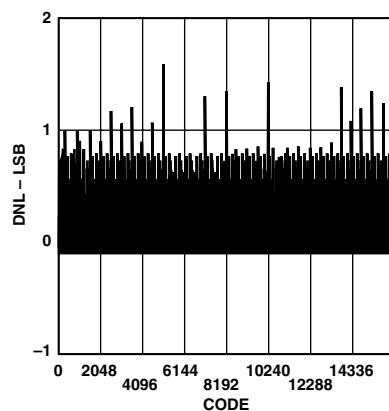

TPC 17. Typical DNL

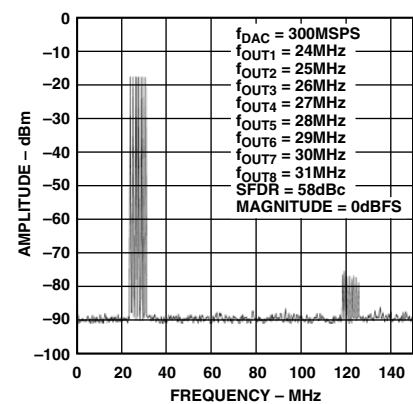

TPC 18. Eight-Tone SFDR @ $f_{OUT} \approx f_{DAC}/11$, $f_{DAC} = 300$ MSPS

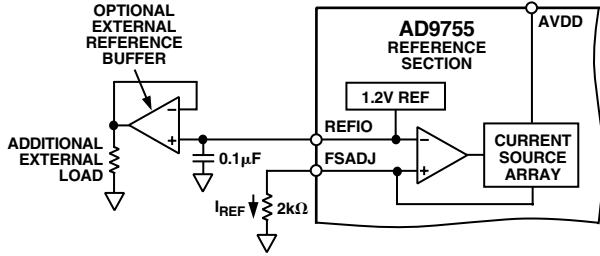

Figure 4. Internal Reference Configuration

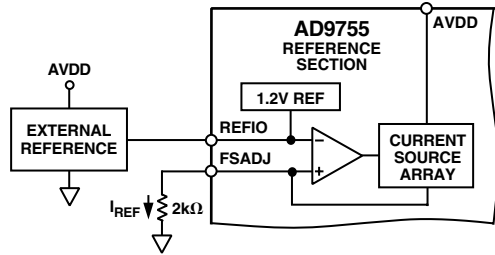

Figure 5. External Reference Configuration

PLL CLOCK MULTIPLIER OPERATION

The Phase Locked Loop (PLL) is intrinsic to the operation of the AD9755 in that it produces the necessary internally synchronized 2× clock for the edge-triggered latches, multiplexer, and DAC.

With PLLVDD connected to its supply voltage, the AD9755 is in PLL ACTIVE mode. Figure 6 shows a functional block diagram of the AD9755 clock control circuitry with PLL active. The circuitry consists of a phase detector, charge pump, voltage controlled oscillator (VCO), input data rate range control, clock logic circuitry and control input/outputs. The ÷2 logic in the feedback loop allows the PLL to generate the 2× clock needed for the DAC output latch.

Figure 7 defines the input and output timing for the AD9755 with the PLL active. CLK in Figure 7 represents the clock that is generated external to the AD9755. The input data at both ports 1 and 2 is latched on the same CLK rising edge. CLK may be applied as a single ended signal by tying CLK- to mid supply and applying CLK to CLK+, or as a differential signal applied to CLK+ and CLK-.

RESET has no purpose when using the internal PLL and should be grounded. When the AD9755 is in PLL ACTIVE mode, PLLLOCK is the output of the internal phase detector. When locked, the lock output in this mode will be a Logic “1.”

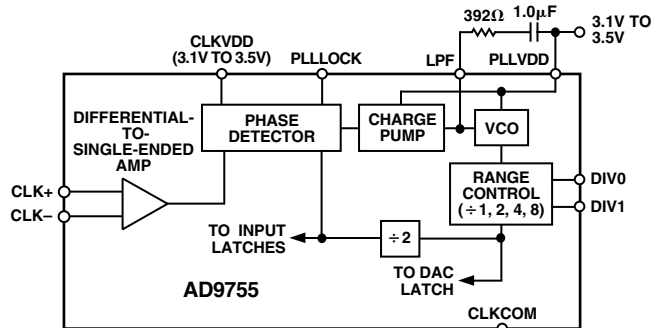
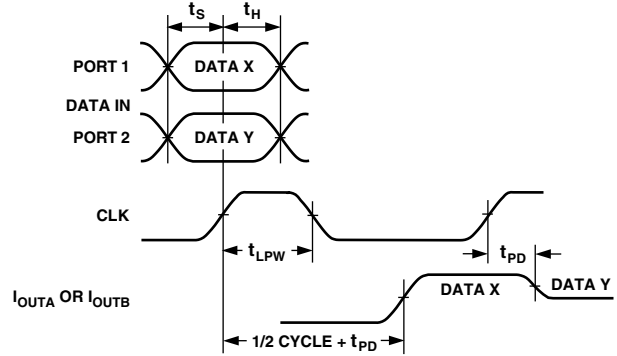
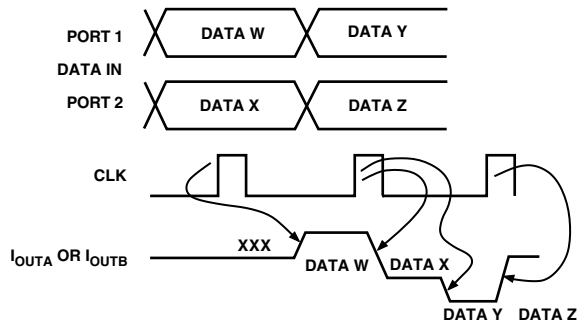

Figure 6. Clock Circuitry with PLL Active



7a.



7b.

Figure 7. DAC Input Timing Requirements with PLL Active

Typically, the VCO can generate outputs of 100 MHz to 400 MHz. The range control is used to keep the VCO operating within its designed range, while allowing input clocks as low as 6.25 MHz. With the PLL active, logic levels at DIV0 and DIV1 determine the divide (prescaler) ratio of the range controller. Table I gives the frequency range of the input clock for the different states of DIV0 and DIV1.

Table I. CLK Rates for DIV0, DIV1 Levels With PLL Active

| CLK Frequency | DIV1 | DIV0 | Range Controller |
|-----------------|------|------|------------------|
| 50 MHz–150 MHz | 0 | 0 | ÷1 |
| 25 MHz–100 MHz | 0 | 1 | ÷2 |
| 12.5 MHz–50 MHz | 1 | 0 | ÷4 |
| 6.25 MHz–25 MHz | 1 | 1 | ÷8 |

A 392 Ω resistor and 1.0 µF capacitor connected in series from LPF to PLLVDD are required to optimize the phase noise vs. settling/acquisition time characteristics of the PLL. To obtain optimum noise and distortion performance, PLLVDD should be set to a voltage level similar to DVDD and CLKVDD.

In general, the best phase noise performance for any PLL range control setting is achieved with the VCO operating near its maximum output frequency of 400 MHz.

As stated earlier, applications requiring input data rates below 6.25 MSPS must disable the PLL clock multiplier and provide an external 2× reference clock. At higher data rates however, applications already containing a low phase noise (i.e., jitter) reference clock that is twice the input data rate should consider disabling the PLL clock multiplier to achieve the best SNR performance from the AD9755. Note, the SFDR performance of the AD9755 remains unaffected with or without the PLL clock multiplier enabled.

The effects of phase noise on the AD9755's SNR performance become more noticeable at higher reconstructed output frequencies and signal levels. Figure 8 compares the phase noise of a full-scale sine wave at exactly $f_{DATA}/4$ at different data rates (hence carrier frequency) with the optimum DIV1, DIV0 setting.

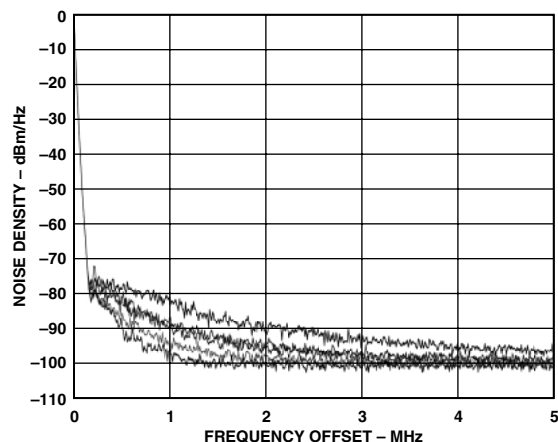

Figure 8. Phase Noise of PLL Clock Multiplier at $f_{OUT} = f_{DATA}/4$ at Different f_{DATA} Settings with DIV0/DIV1 Optimized, Using R & S FSEA30 Spectrum Analyzer

SNR is partly a function of the jitter generated by the clock circuitry. As a result, any noise on PLLVDD or CLKVDD may decrease the SNR at the output of the DAC. To minimize this potential problem, PLLVDD and CLKVDD can be connected to DVDD using an LC filter network similar to that shown in Figure 9.

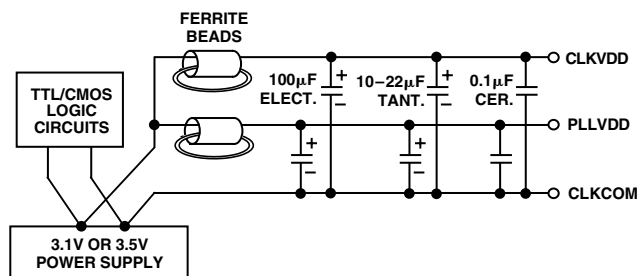

Figure 9. LC Network for Power Filtering

DAC TIMING WITH PLL ACTIVE

As described previously in Figure 7, in PLL ACTIVE mode, Port 1 and Port 2 input latches are updated on the rising edge of CLK. On the same rising edge, data previously present in the input Port 2 latch is written to the DAC output latch. The DAC output will update after a short propagation delay (t_{PD}).

Following the rising edge of CLK, at a time equal to half of its period, the data in the Port 1 latch will be written to the DAC output latch, again with a corresponding change in the DAC output. Due to the internal PLL, the time at which the data in the Port 1 and Port 2 input latches is written to the DAC latch is independent of the duty cycle of CLK. When using the PLL, the external clock can be operated at any duty cycle that meets the specified input pulsewidth.

On the next rising edge of CLK, the cycle begins again with the two input port latches being updated, and the DAC output latch being updated with the current data in the Port 2 input latch.

PLL DISABLED MODE

When PLLVDD is grounded, the PLL is disabled. An external clock must now drive the CLK inputs at the desired DAC output update rate. The speed and timing of the data present at input Ports 1 and 2 are now dependent on whether or not the AD9755 is interleaving the digital input data, or only responding to data on a single port. Figure 10 is a functional block diagram of the AD9755 clock control circuitry with the PLL disabled.

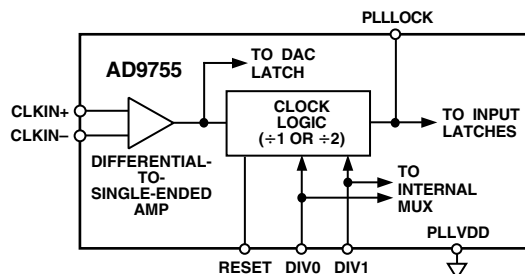

Figure 10. Clock Circuitry with PLL Disabled

DIV0 and DIV1 no longer control the PLL, but are used to set the control on the input mux for either interleaving or non-interleaving the input data. The different modes for states of DIV0 and DIV1 are given in Table II.

Table II. Input Mode for DIV0, DIV1 Levels with PLL Disabled

| Input Mode | DIV1 | DIV0 |
|------------------|------|------|
| Interleaved (2x) | 0 | 0 |
| Noninterleaved | | |
| Port 1 Selected | 0 | 1 |
| Port 2 Selected | 1 | 0 |
| Not Allowed | 1 | 1 |

AD9755

INTERLEAVED (2×) MODE WITH PLL DISABLED

The relationship between the internal and external clocks in this mode is shown in Figure 11. A clock at the output update data rate (2× the input data rate) must be applied to the CLK inputs. Internal dividers then create the internal 1× clock necessary for the input latches. Although the input latches are updated on the rising edge of the delayed internal 1× clock, the setup-and-hold times given in the Digital Specifications table are with respect to the rising edge of the external 2× clock. With the PLL disabled, a load-dependent delayed version of the 1× clock is present at the PLLLOCK pin. This signal can be used to synchronize the external data.

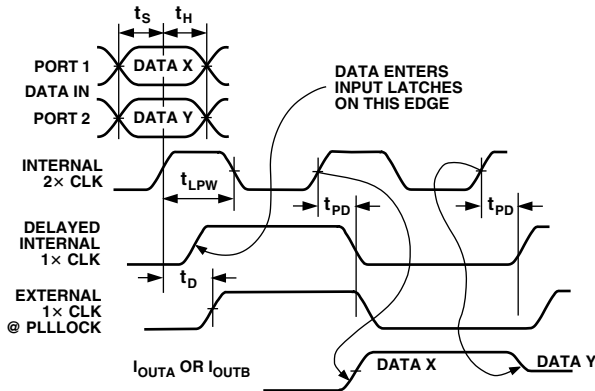

Figure 11. Timing Requirements, Interleaved (2×) Mode With PLL Disabled

Updates to the data at input Ports 1 and 2 should be synchronized to the specific rising edge of the external 2× clock which corresponds to the rising edge of the 1× internal clock as shown in Figure 11. To ensure synchronization, a Logic “1” must be momentarily applied to the RESET pin. Doing this and returning RESET to Logic “0” brings the 1× clock at PLLLOCK to a Logic “1.” On the next rising edge of the 2× clock, the 1× clock will go to Logic “0.” On the second rising edge of the 2× clock, the 1× clock (PLLLOCK) will again go to Logic “1,” as well as update the data in both of the input latches. The details of this are given in Figure 12.

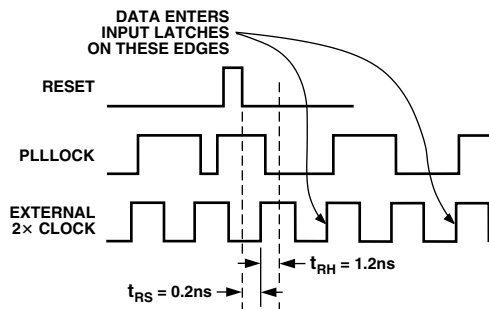

Figure 12. Reset Function Timing with PLL Disabled

For proper synchronization, sufficient delay must be present between the time RESET goes low and the rising edge of the 2× clock. RESET going low must occur either at least t_{RS} ns before the rising edge of the 2× clock, or t_{RH} ns afterwards. In the former case, the immediately occurring CLK rising edge will cause PLLLOCK to go low. In the latter case, the next CLK rising edge will toggle PLLLOCK.

NONINTERLEAVED MODE WITH PLL DISABLED

If the data at only one port is required, the AD9755 interface can operate as a simple double buffered latch with no interleaving. On the rising edge of the 1× clock, input latch 1 or 2 is updated with the present input data (depending on the state of DIV0/DIV1). On the next rising edge, the DAC latch is updated and a time t_{PD} later, the DAC output reflects this change. Figure 13 represents the AD9755 timing in this mode.

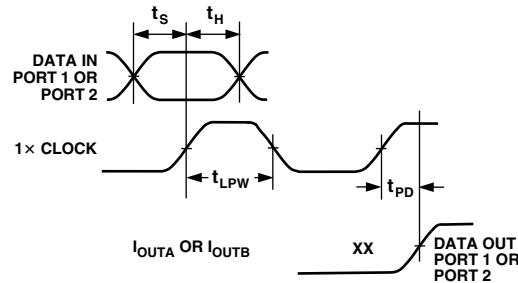

Figure 13. Timing Requirements, Noninterleaved Mode with PLL Disabled

DAC TRANSFER FUNCTION

The AD9755 provides complementary current outputs, I_{OUTA} and I_{OUTB} . I_{OUTA} will provide a near full-scale current output, I_{OUTFS} , when all bits are high (i.e., DAC CODE = 16383) while I_{OUTB} , the complementary output, provides no current. The current output appearing at I_{OUTA} and I_{OUTB} is a function of both the input code and I_{OUTFS} , and can be expressed as:

$$I_{OUTA} = (DAC\ CODE/16383) \times I_{OUTFS} \quad (1)$$

$$I_{OUTB} = (16383 - DAC\ CODE)/16384 \times I_{OUTFS} \quad (2)$$

where $DAC\ CODE = 0$ to 16383 (i.e., Decimal Representation).

As mentioned previously, I_{OUTFS} is a function of the reference current I_{REF} , which is nominally set by a reference voltage, V_{REFIO} , and external resistor R_{SET} . It can be expressed as:

$$I_{OUTFS} = 32 \times I_{REF} \quad (3)$$

$$\text{where } I_{REF} = V_{REFIO}/R_{SET} \quad (4)$$

The two current outputs will typically drive a resistive load directly or via a transformer. If dc-coupling is required, I_{OUTA} and I_{OUTB} should be directly connected to matching resistive loads, R_{LOAD} , that are tied to analog common, ACOM. Note, R_{LOAD} may represent the equivalent load resistance seen by I_{OUTA} or I_{OUTB} as would be the case in a doubly terminated 50 Ω or 75 Ω cable. The single-ended voltage output appearing at the I_{OUTA} and I_{OUTB} nodes is simply :

$$V_{OUTA} = I_{OUTA} \times R_{LOAD} \quad (5)$$

$$V_{OUTB} = I_{OUTB} \times R_{LOAD} \quad (6)$$

Note the full-scale value of V_{OUTA} and V_{OUTB} should not exceed the specified output compliance range to maintain specified distortion and linearity performance.

$$V_{DIFF} = (I_{OUTA} - I_{OUTB}) \times R_{LOAD} \quad (7)$$

Substituting the values of I_{OUTA} , I_{OUTB} and I_{REF} , V_{DIFF} can be expressed as:

$$V_{DIFF} = \{(2\ DAC\ CODE - 16383)/16384\} \times (32\ R_{LOAD}/R_{SET}) \times V_{REFIO} \quad (8)$$

These last two equations highlight some of the advantages of operating the AD9755 differentially. First, the differential operation will help cancel common-mode error sources associated with I_{OUTA} and I_{OUTB} such as noise, distortion, and dc offsets. Second, the differential code-dependent current and subsequent voltage, V_{DIFF} , is twice the value of the single-ended voltage output (i.e., V_{OUTA} or V_{OUTB}), thus providing twice the signal power to the load.

Note that the gain drift temperature performance for a single-ended (V_{OUTA} and V_{OUTB}) or differential output (V_{DIFF}) of the AD9755 can be enhanced by selecting temperature tracking resistors for R_{LOAD} and R_{SET} due to their ratiometric relationship as shown in Equation 8.

ANALOG OUTPUTS

The AD9755 produces two complementary current outputs, I_{OUTA} and I_{OUTB} , which may be configured for single-ended or differential operation. I_{OUTA} and I_{OUTB} can be converted into complementary single-ended voltage outputs, V_{OUTA} and V_{OUTB} , via a load resistor, R_{LOAD} , as described by Equations 5 through 8 in the DAC Transfer Function section. The differential voltage, V_{DIFF} , existing between V_{OUTA} and V_{OUTB} can also be converted to a single-ended voltage via a transformer or differential amplifier configuration. The ac performance of the AD9755 is optimum and specified using a differential transformer coupled output in which the voltage swing at I_{OUTA} and I_{OUTB} is limited to ± 0.5 V. If a single-ended unipolar output is desirable, I_{OUTA} should be selected as the output, with I_{OUTB} grounded.

The distortion and noise performance of the AD9755 can be enhanced when it is configured for differential operation. The common-mode error sources of both I_{OUTA} and I_{OUTB} can be significantly reduced by the common-mode rejection of a transformer or differential amplifier. These common-mode error sources include even-order distortion products and noise. The enhancement in distortion performance becomes more significant as the frequency content of the reconstructed waveform increases. This is due to the first order cancellation of various dynamic common-mode distortion mechanisms, digital feed-through and noise.

Performing a differential-to-single-ended conversion via a transformer also provides the ability to deliver twice the reconstructed signal power to the load (i.e., assuming no source termination). Since the output currents of I_{OUTA} and I_{OUTB} are complementary, they become additive when processed differentially. A properly selected transformer will allow the AD9755 to provide the required power and voltage levels to different loads. Refer to Applying the AD9755 section for examples of various output configurations.

The output impedance of I_{OUTA} and I_{OUTB} is determined by the equivalent parallel combination of the PMOS switches associated with the current sources and is typically 100 k Ω in parallel with 5 pF. It is also slightly dependent on the output voltage (i.e., V_{OUTA} and V_{OUTB}) due to the nature of a PMOS device. As a result, maintaining I_{OUTA} and/or I_{OUTB} at a virtual ground via an I-V op amp configuration will result in the optimum dc linearity. Note that the INL/DNL specifications for the AD9755 are measured with I_{OUTA} and I_{OUTB} maintained at virtual ground via an op amp.

I_{OUTA} and I_{OUTB} also have a negative and positive voltage compliance range that must be adhered to in order to achieve optimum performance. The negative output compliance range of -1.0 V is set by the breakdown limits of the CMOS process. Operation beyond this maximum limit may result in a breakdown of the output stage and affect the reliability of the AD9755.

The positive output compliance range is slightly dependent on the full-scale output current, I_{OUTFS} . It degrades slightly from its nominal 1.25 V for an $I_{OUTFS} = 20$ mA to 1.00 V for an $I_{OUTFS} = 2$ mA. The optimum distortion performance for a single-ended or differential output is achieved when the maximum full-scale signal at I_{OUTA} and I_{OUTB} does not exceed 0.5 V. Applications requiring the AD9755's output (i.e., V_{OUTA} and/or V_{OUTB}) to extend its output compliance range should size R_{LOAD} accordingly. Operation beyond this compliance range will adversely affect the AD9755's linearity performance and subsequently degrade its distortion performance.

DIGITAL INPUTS

The AD9755's digital inputs consist of two channels of 14 data input pins each and a pair of differential clock input pins. The 14-bit parallel data inputs follow standard straight binary coding where DB13 is the most significant bit (MSB) and DB0 is the least significant bit (LSB). I_{OUTA} produces a full-scale output current when all data bits are at Logic 1. I_{OUTB} produces a complementary output with the full-scale current split between the two outputs as a function of the input code.

The digital interface is implemented using an edge-triggered master slave latch. With the PLL active or disabled, the DAC output is updated twice for every input latch rising edge, as shown in Figures 7 and 11. The AD9755 is designed to support an input data rate as high as 150 MSPS giving a DAC output update rate of 300 MSPS. The setup-and-hold times can also be varied within the clock cycle as long as the specified minimum times are met. Best performance is typically achieved when the input data transitions on the falling edge of a 50% duty cycle clock.

The digital inputs are CMOS-compatible with logic thresholds, $V_{THRESHOLD}$, set to approximately half the digital positive supply (DVDD) or

$$V_{THRESHOLD} = DVDD/2 (\pm 20\%)$$

The internal digital circuitry of the AD9755 is capable of operating over a digital supply range of 3.1 V to 3.5 V. As a result, the digital inputs can also accommodate TTL levels when DVDD is set to accommodate the maximum high level voltage of the TTL drivers $V_{OH(MAX)}$. A DVDD of 3.1 V to 3.3 V will typically ensure proper compatibility with most TTL logic families. Figure 14 shows the equivalent digital input circuit for the data and clock inputs.

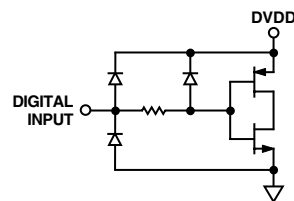

Figure 14. Equivalent Digital Input

AD9755

The AD9755 features a flexible differential clock input operating from separate supplies (i.e., CLKVDD, CLKCOM) to achieve optimum jitter performance. The two clock inputs, CLK+ and CLK-, can be driven from a single-ended or differential clock source. For single-ended operation, CLK+ should be driven by a logic source while CLK- should be set to the threshold voltage of the logic source. This can be done via a resistor divider/capacitor network as shown in Figure 15a. For differential operation, both CLK+ and CLK- should be biased to CLKVDD/2 via a resistor divider network as shown in Figure 15b.

Because the output of the AD9755 is capable of being updated at up to 300 MSPS, the quality of the clock and data input signals are important in achieving the optimum performance. The drivers of the digital data interface circuitry should be specified to meet the minimum setup-and-hold times of the AD9755 as well as its required min/max input logic level thresholds.

Digital signal paths should be kept short and run lengths matched to avoid propagation delay mismatch. The insertion of a low value resistor network (i.e., 20 Ω to 100 Ω) between the AD9755 digital inputs and driver outputs may be helpful in reducing any overshooting and ringing at the digital inputs that contribute to data feedthrough. For longer run lengths and high data update rates, strip line techniques with proper termination resistors should be considered to maintain “clean” digital inputs.

The external clock driver circuitry should provide the AD9755 with a low jitter clock input meeting the min/max logic levels while providing fast edges. Fast clock edges will help minimize any jitter that will manifest itself as phase noise on a reconstructed waveform. Thus, the clock input should be driven by the fastest logic family suitable for the application.

Note that the clock input could also be driven via a sine wave, which is centered around the digital threshold (i.e., DVDD/2) and meets the min/max logic threshold. This will typically result in a slight degradation in the phase noise, which becomes more noticeable at higher sampling rates and output frequencies. Also, at higher sampling rates, the 20% tolerance of the digital logic threshold should be considered since it will affect the effective clock duty cycle and, subsequently, cut into the required data setup and hold times.

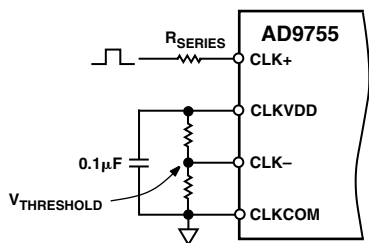

Figure 15a. Single-Ended Clock Interface

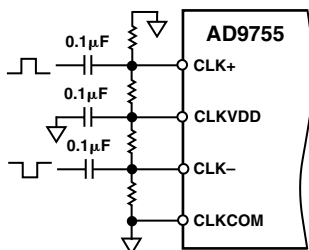

Figure 15b. Differential Clock Interface

INPUT CLOCK AND DATA TIMING RELATIONSHIP

SNR in a DAC is dependent on the relationship between the position of the clock edges and the point in time at which the input data changes. The AD9755 is rising edge triggered, and so exhibits SNR sensitivity when the data transition is close to this edge. In general, the goal when applying the AD9755 is to make the data transition close to the falling clock edge. This becomes more important as the sample rate increases. Figure 16 shows the relationship of SNR to clock placement with different sample rates. Note that the setup and hold times implied in Figure 16 appear to violate the maximums stated in the Digital Specifications of this data sheet. The variation in Figure 16 is due to the skew present between data bits inherent in the digital data generator used to perform these tests. Figure 16 is presented to show the effects of violating setup and hold times, and to show the insensitivity of the AD9755 to clock placement when data transitions fall outside of the so-called “bad window.” The setup and hold times stated in the Digital Specifications were measured on a bit-by-bit basis, therefore eliminating the skew present in the digital data generator. At higher data rates, it becomes very important to account for the skew in the input digital data when defining timing specifications.

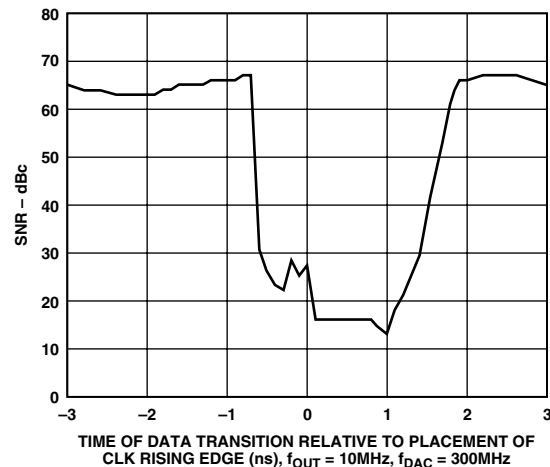

Figure 16. SNR vs. Time of Data Transition Relative to Clock Rising Edge

POWER DISSIPATION

The power dissipation, P_D , of the AD9755 is dependent on several factors that include: (1) The power supply voltages ($AVDD$ and $DVDD$), (2) the full-scale current output I_{OUTFS} , (3) the update rate f_{CLOCK} , and (4) the reconstructed digital input waveform. The power dissipation is directly proportional to the analog supply current, I_{AVDD} , and the digital supply current, I_{DVDD} . I_{AVDD} is directly proportional to I_{OUTFS} as shown in Figure 17, and is insensitive to f_{CLOCK} . Conversely, I_{DVDD} is dependent on both the digital input waveform, f_{CLOCK} , and digital supply $DVDD$. Figure 18 shows I_{DVDD} as a function of the ratio (f_{OUT}/f_{DAC}) for various update rates. In addition, Figure 19 shows the effect that the speed of f_{DAC} has on the PLLVDD current, given the PLL divider ratio.

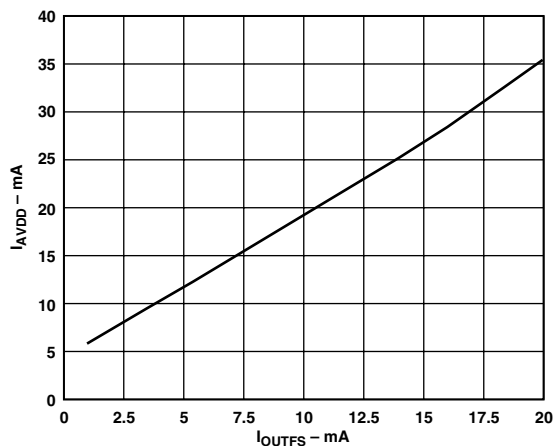

Figure 17. I_{AVDD} vs. I_{OUTFS}

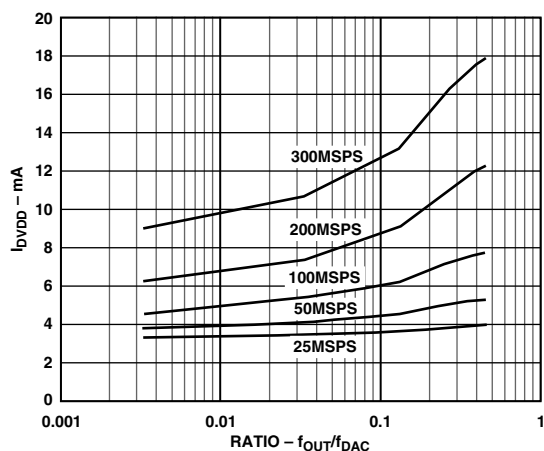

Figure 18. I_{DVDD} vs. f_{OUT}/f_{DAC} Ratio

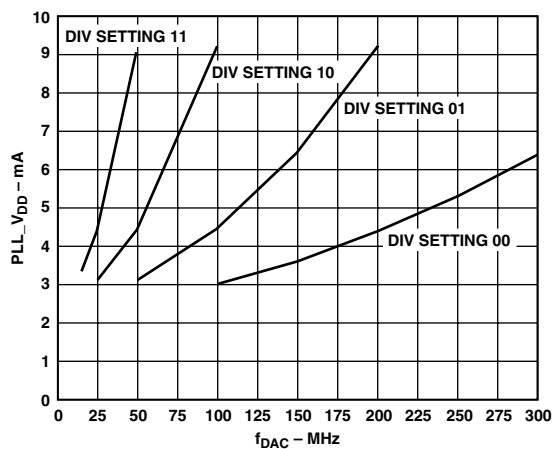

Figure 19. PLL_{VDD} vs. f_{DAC}

APPLYING THE AD9755 OUTPUT CONFIGURATIONS

The following sections illustrate some typical output configurations for the AD9755. Unless otherwise noted, it is assumed that I_{OUTFS} is set to a nominal 20 mA. For applications requiring the optimum dynamic performance, a differential output configuration may consist of either an RF transformer or a differential op amp configuration. The transformer configuration provides the optimum high-frequency performance and is recommended for any application allowing for ac-coupling. The differential op amp configuration is suitable for applications requiring dc-coupling, a bipolar output, signal gain, and/or level-shifting, within the bandwidth of the chosen op amp.

A single-ended output is suitable for applications requiring a unipolar voltage output. A positive unipolar output voltage will result if I_{OUTA} and/or I_{OUTB} are connected to an appropriately sized load resistor, R_{LOAD} , referred to ACOM. This configuration may be more suitable for a single-supply system requiring a dc-coupled, ground referred output voltage. Alternatively, an amplifier could be configured as an I-V converter, thus converting I_{OUTA} or I_{OUTB} into a negative unipolar voltage. This configuration provides the best dc linearity since I_{OUTA} or I_{OUTB} is maintained at a virtual ground. Note that I_{OUTA} provides slightly better performance than I_{OUTB} .

DIFFERENTIAL COUPLING USING A TRANSFORMER

An RF transformer can be used to perform a differential-to-single-ended signal conversion as shown in Figure 20. A differentially coupled transformer output provides the optimum distortion performance for output signals whose spectral content lies within the transformer's passband. An RF transformer such as the Mini-Circuits T1-1T provides excellent rejection of common-mode distortion (i.e., even-order harmonics) and noise over a wide frequency range. When I_{OUTA} and I_{OUTB} are terminated to ground with 50 Ω , this configuration provides 0 dBm power to a 50 Ω load on the secondary with a DAC full-scale current of 20 mA. A 2:1 transformer such as the Coilcraft WB2040-PC can also be used in a configuration in which I_{OUTA} and I_{OUTB} are terminated to ground with 75 Ω . This configuration improves load matching and increases power to 2 dBm into a 50 Ω load on the secondary. Transformers with different impedance ratios may also be used for impedance matching purposes. Note that the transformer provides ac-coupling only.

The center tap on the primary side of the transformer must be connected to ACOM to provide the necessary dc current path for both I_{OUTA} and I_{OUTB} . The complementary voltages appearing at I_{OUTA} and I_{OUTB} (i.e., V_{OUTA} and V_{OUTB}) swing symmetrically around ACOM and should be maintained with the specified output compliance range of the AD9755. A differential resistor, R_{DIFF} , may be inserted in applications where the output of the transformer is connected to the load, R_{LOAD} , via a passive reconstruction filter or cable. R_{DIFF} is determined by the transformer's impedance ratio and provides the proper source termination that results in a low VSWR.

AD9755

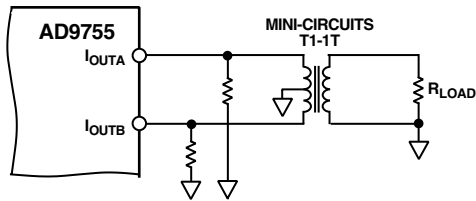

Figure 20. Differential Output Using a Transformer

DIFFERENTIAL COUPLING USING AN OP AMP

An op amp can also be used to perform a differential-to-single-ended conversion as shown in Figure 21. The AD9755 is configured with two equal load resistors, R_{LOAD} , of 25 Ω . The differential voltage developed across I_{OUTA} and I_{OUTB} is converted to a single-ended signal via the differential op amp configuration. An optional capacitor can be installed across I_{OUTA} and I_{OUTB} , forming a real pole in a low-pass filter. The addition of this capacitor also enhances the op amp's distortion performance by preventing the DAC's high slewing output from overloading the op amp's input.

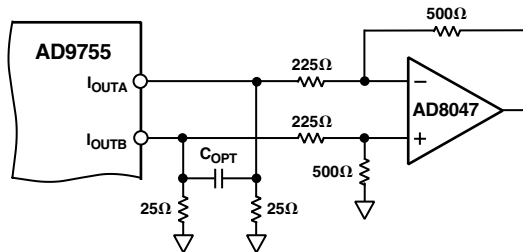

Figure 21. DC Differential Coupling Using an Op Amp

The common-mode rejection of this configuration is typically determined by the resistor matching. In this circuit, the differential op amp circuit using the AD8047 is configured to provide some additional signal gain. The op amp must operate from a dual supply since its output is approximately ± 1.0 V. A high-speed amplifier capable of preserving the differential performance of the AD9755, while meeting other system level objectives (i.e., cost, power), should be selected. The op amp's differential gain, its gain setting resistor values, and full-scale output swing capabilities should all be considered when optimizing this circuit.

The differential circuit shown in Figure 22 provides the necessary level-shifting required in a single supply system. In this case, AVDD, which is the positive analog supply for both the AD9755 and the op amp, is also used to level-shift the differential output of the AD9755 to midsupply (i.e., AVDD/2). The AD8041 is a suitable op amp for this application.

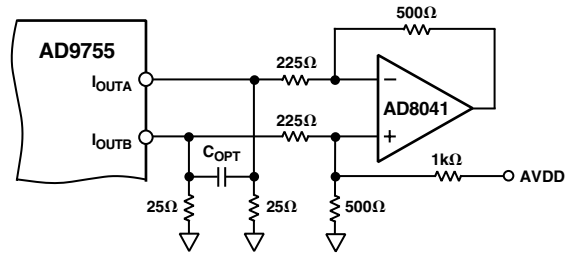

Figure 22. Single Supply DC Differential Coupled Circuit

SINGLE-ENDED UNBUFFERED VOLTAGE OUTPUT

Figure 23 shows the AD9755 configured to provide a unipolar output range of approximately 0 V to 0.5 V for a doubly terminated 50 Ω cable since the nominal full-scale current, I_{OUTFS} , of 20 mA flows through the equivalent R_{LOAD} of 25 Ω . In this case, R_{LOAD} represents the equivalent load resistance seen by I_{OUTA} or I_{OUTB} . The unused output (I_{OUTA} or I_{OUTB}) can be connected to ACOM directly or via a matching R_{LOAD} . Different values of I_{OUTFS} and R_{LOAD} can be selected as long as the positive compliance range is adhered to. One additional consideration in this mode is the integral nonlinearity (INL) as discussed in the Analog Output section of this data sheet. For optimum INL performance, the single-ended, buffered voltage output configuration is suggested.

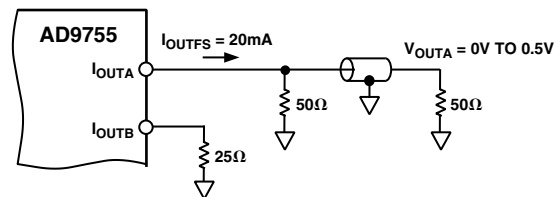

Figure 23. 0 V to 0.5 V Unbuffered Voltage Output

SINGLE-ENDED, BUFFERED VOLTAGE OUTPUT

Figure 24 shows a buffered single-ended output configuration in which the op amp performs an I-V conversion on the AD9755 output current. The op amp maintains I_{OUTA} (or I_{OUTB}) at a virtual ground, thus minimizing the nonlinear output impedance effect on the DAC's INL performance as discussed in the Analog Output section. Although this single-ended configuration typically provides the best dc linearity performance, its ac distortion performance at higher DAC update rates may be limited by the op amp's slewing capabilities. The op amp provides a negative unipolar output voltage and its full-scale output voltage is simply the product of R_{FB} and I_{OUTFS} . The full-scale output should be set within the op amp's voltage output swing capabilities by scaling I_{OUTFS} and/or R_{FB} . An improvement in ac distortion performance may result with a reduced I_{OUTFS} , since the signal current the op amp will be required to sink will be subsequently reduced.

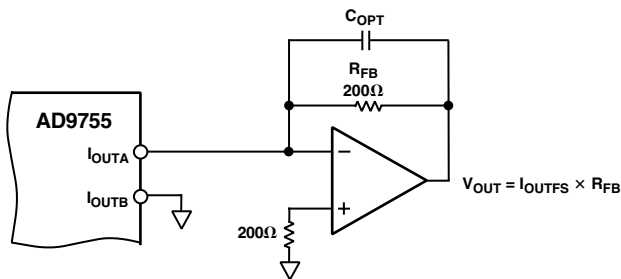

Figure 24. Unipolar Buffered Voltage Output

POWER AND GROUNDING CONSIDERATIONS, POWER SUPPLY REJECTION

Many applications seek high speed and high performance under less than ideal operating conditions. In these applications, the implementation and construction of the printed circuit board is as important as the circuit design. Proper RF techniques must be used for device selection, placement, and routing, as well as power supply bypassing and grounding to ensure optimum performance. Figures 34 to 41 illustrate the recommended printed circuit board ground, power and signal plane layouts which are implemented on the AD9755 evaluation board.

One factor that can measurably affect system performance is the ability of the DAC output to reject dc variations or ac noise superimposed on the analog or digital dc power distribution. This is referred to as the Power Supply Rejection Ratio. For dc variations of the power supply, the resulting performance of the DAC directly corresponds to a gain error associated with the DAC’s full-scale current, I_{OUTFS} . AC noise on the dc supplies is common in applications where the power distribution is generated by a switching power supply. Typically, switching power supply noise will occur over the spectrum from tens of kHz to several MHz. The PSRR vs. frequency of the AD9755 AVDD supply over this frequency range is shown in Figure 25.

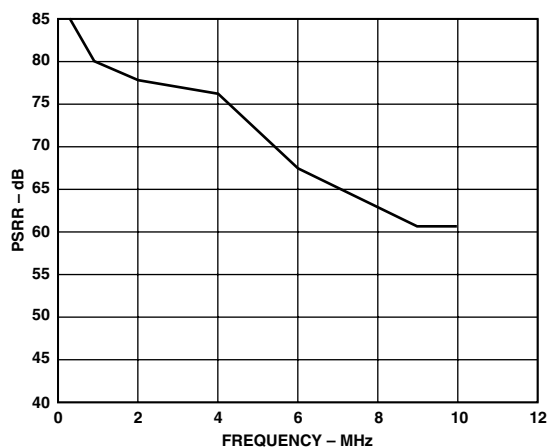

Figure 25. Power Supply Rejection Ratio

Note that the units in Figure 25 are given in units of (amps out/volts in). Noise on the analog power supply has the effect of modulating the internal switches, and therefore the output current. The voltage noise on AVDD will thus be added in a nonlinear manner to the desired I_{OUT} . Due to the relative different size of these switches, PSRR is very code-dependent. This can produce a mixing effect that can modulate low frequency power supply noise to higher frequencies. Worst-case PSRR for either one of the differential DAC outputs will occur when the full-scale current is directed toward that output. As a result, the PSRR measurement in Figure 25 represents a worst-case condition in which the digital inputs remain static and the full-scale output current of 20 mA is directed to the DAC output being measured.

An example serves to illustrate the effect of supply noise on the analog supply. Suppose a switching regulator with a switching frequency of 250 kHz produces 10 mV rms of noise and, for simplicity sake (i.e., ignore harmonics), all of this noise is concentrated at 250 kHz. To calculate how much of this undesired noise will appear as current noise superimposed on the DAC’s full-scale current, I_{OUTFS} , one must determine the PSRR in dB using Figure 25 at 250 kHz. To calculate the PSRR for a given R_{LOAD} , such that the units of PSRR are converted from A/V to V/V, adjust the curve in Figure 25 by the scaling factor $20 \times \text{Log}(R_{LOAD})$. For instance, if R_{LOAD} is 50 Ω, the PSRR is reduced by 34 dB (i.e., PSRR of the DAC at 250 kHz, which is 85 dB in Figure 25, becomes 51 dB V_{OUT}/V_{IN}).

Proper grounding and decoupling should be a primary objective in any high-speed, high-resolution system. The AD9755 features separate analog and digital supply and ground pins to optimize the management of analog and digital ground currents in a system. In general, AVDD, the analog supply, should be decoupled to ACOM, the analog common, as close to the chip as physically possible. Similarly, DVDD, the digital supply, should be decoupled to DCOM as close to the chip as physically possible.

For those applications that require a single 3.3 V supply for both the analog and digital supplies, a clean analog supply may be generated using the circuit shown in Figure 26. The circuit consists of a differential LC filter with separate power supply and return lines. Lower noise can be attained by using low ESR type electrolytic and tantalum capacitors.

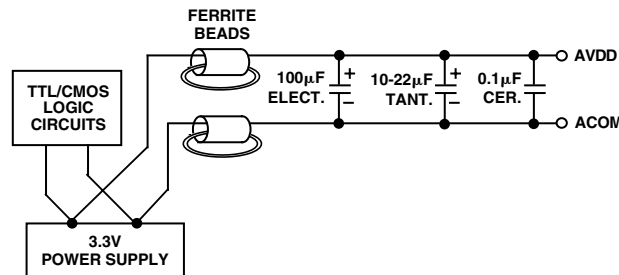

Figure 26. Differential LC Filter for a Single 3.3 V Application

AD9755

APPLICATIONS

QAM/PSK Synthesis

Quadrature modulation (QAM or PSK) consists of two baseband PAM (Pulse Amplitude Modulated) data channels. Both channels are modulated by a common frequency carrier. However, the carriers for each channel are phase-shifted 90° from each other. This orthogonality allows twice the spectral efficiency (data for a given bandwidth) of digital data transmitted via AM. Receivers can be designed which selectively choose the ‘in phase’ and ‘quadrature’ carriers, and then recombine the data. The recombination of the QAM data can be mapped as points representing digital words in a two dimensional constellation as shown in Figure 27. Each point, or symbol, represents the transmission of multiple bits in one symbol period.

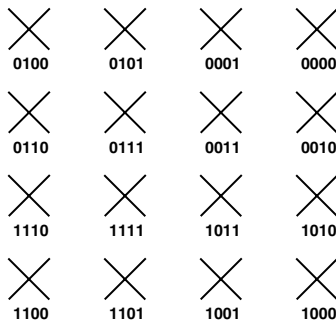

Figure 27. 16 QAM Constellation, Gray Coded (Two 4-Level PAM Signals with Orthogonal Carriers)

Typically, the I and Q data channels are quadrature-modulated in the digital domain. The high data rate of the AD9755 allows extremely wide band (>10 MHz) quadrature carriers to be synthesized at IFs of over 100 MHz. Figure 28 shows an example of a 25 MSymbol/S QAM signal, raised cosine-like pulse, oversampled by eight at a data rate of 200 MSPS modulated onto a 25 MHz carrier and reconstructed using the AD9755.

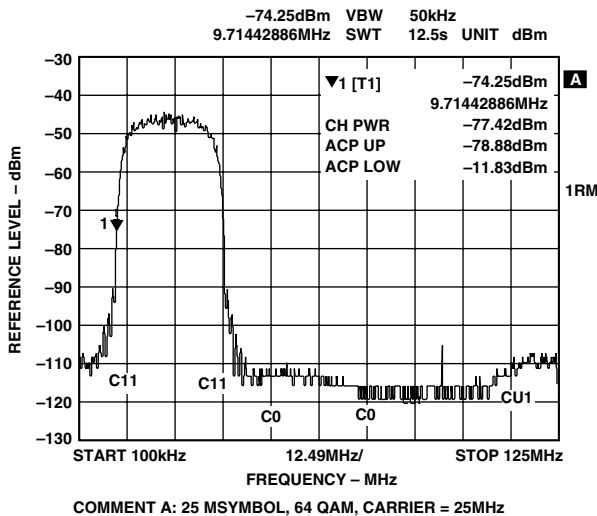

Figure 28. Reconstructed 64-QAM Signal at 25 MHz IF

A figure of merit for wideband signal synthesis is the ratio of signal power in the transmitted band to the power in an adjacent channel. In Figure 28, the adjacent channel power ratio (ACPR) at the output of the AD9755 is measured to be 65 dB. The limitation on making a measurement of this type is often not the DAC but the noise inherent in creating the digital data record using computer tools. To find how much this is limiting the perceived DAC performance, the signal amplitude can be reduced, as is shown in Figure 29. The noise contributed by the DAC will remain constant as the signal amplitude is reduced. When the signal amplitude is reduced to the level where the noise floor drops below that of the spectrum analyzer, ACPR will fall off at the same rate that the signal level is being reduced. Under the conditions measured in Figure 28, this point occurs in Figure 29 at -10 dBFS. This shows that the data record is actually degrading the measured ACPR by up to 10 dB.

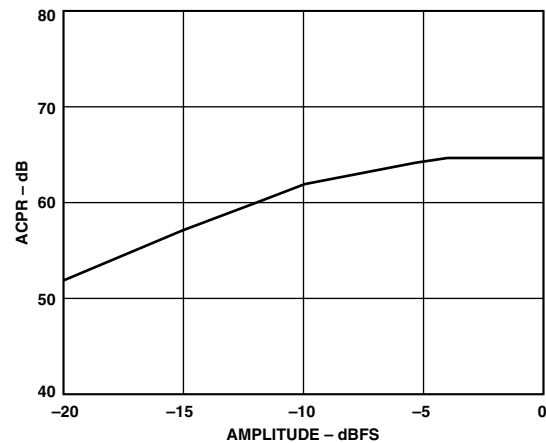

Figure 29. ACPR vs. Amplitude for QAM Carrier

A single-channel active mixer such as the Analog Devices AD8343 can then be used for the hop to the transmit frequency. Figure 30 shows an applications circuit using the AD9755 and the AD8343. The AD8343 is capable of mixing carriers from dc to 2.5 GHz. Figure 31 shows the result of mixing the signal in Figure 28 up to a carrier frequency of 800 MHz. ACPR measured at the output of the AD8343 is shown in Figure 31 to be 60 dB.

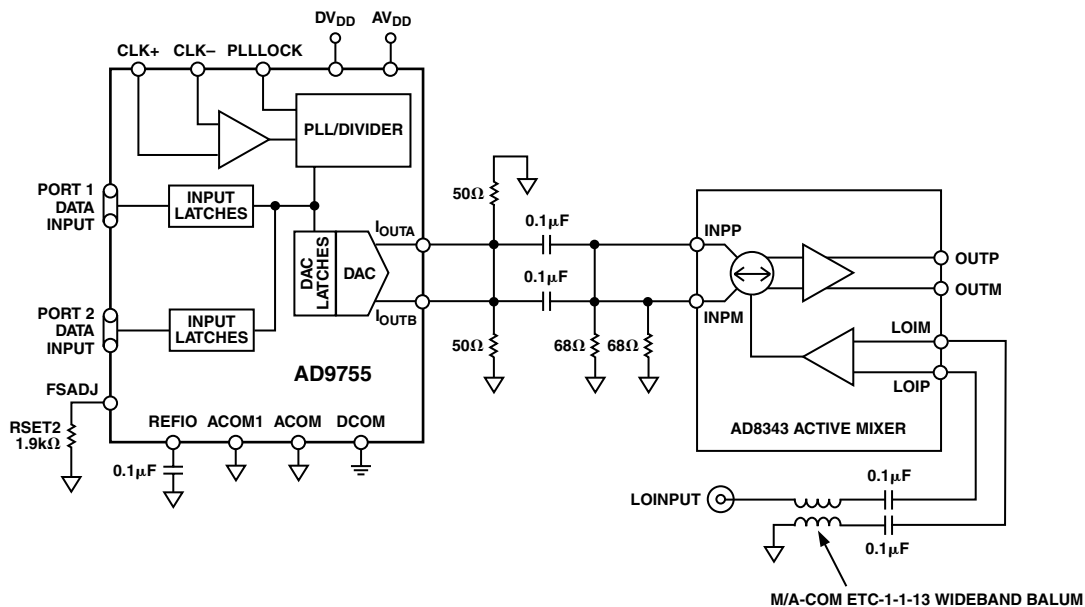

Figure 30. QAM Transmitter Architecture Using AD9755 and AD8343 Active Mixer

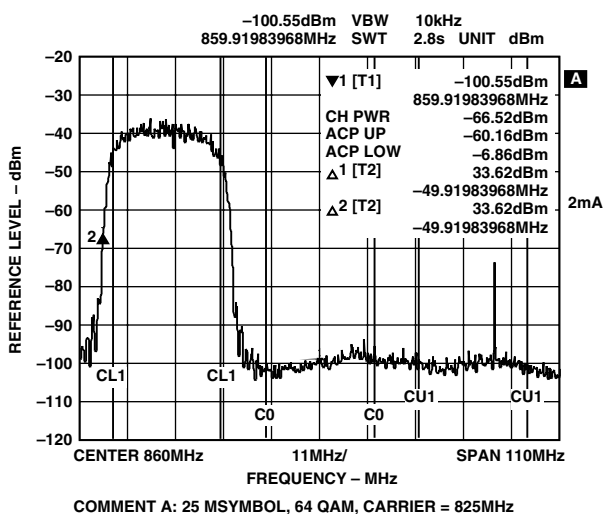

Figure 31. Signal of Figure 28 Mixed to Carrier Frequency of 800 MHz

Effects of Noise and Distortion on Bit Error Rate (BER)

Textbook analysis of Bit Error Rate (BER) performance are generally stated in terms of E (energy in watts-per-symbol or watts-per-bit) and N_0 (spectral noise density in watts/Hz). For QAM signals, this performance is shown graphically in Figure 32. M represents the number of levels in each quadrature PAM signal (i.e., $M = 8$ for 64 QAM, $M = 16$ for 256 QAM). Figure 32 implies grey coding in the QAM constellation, as well as the use of matched filters at the receiver, which is typical. The horizontal axis of Figure 32 can be converted to units of energy/symbol by adding to the horizontal axis $10 \log$ of the number of bits in the desired curve. For instance, to achieve a BER of $1e-6$ with 64 QAM, an energy per bit of 20 dB is necessary. To calculate energy per symbol, we add $10 \log(6)$, or 7.8 dB. 64 QAM with a BER of $1e-6$ (assuming no source or channel coding) can therefore theoretically be achieved with an energy/symbol-to-noise (E/N_0) ratio of 27.8 dB. Due to the loss and

interferers inherent in the wireless path, this signal-to-noise ratio must be realized at the receiver to achieve the given bit error rate.

Distortion effects on BER are much more difficult to determine accurately. Most often in simulation, the energies of the strongest distortion components are root-sum-squared with the noise, and the result is treated as if it were all noise. That being said, if the example above of 64 QAM with the BER of $1e-6$, using the E/N_0 ratio is much greater than the worst-case SFDR, the noise will dominate the BER calculation.

The AD9755 has a worst-case in-band SFDR of 47 dB at the upper end of its frequency spectrum (see TPCs 2, 3). When used to synthesize high-level QAM signals as described above, noise, as opposed to distortion, will dominate its performance in these applications.

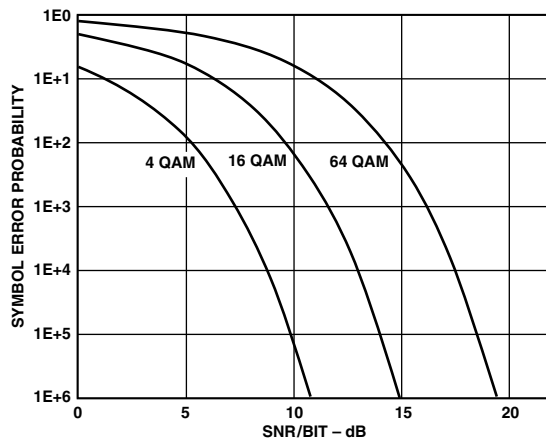

Figure 32. Probability of a Symbol Error for QAM

AD9755

Pseudo Zero Stuffing/IF Mode

The excellent dynamic range of the AD9755 allows its use in applications where synthesis of multiple carriers is desired. In addition, the AD9755 can be used in a pseudo zero-stuffing mode which improves dynamic range at IF frequencies. In this mode, data from the two input channels is interleaved to the DAC, which is running at twice the speed of either of the input ports. However, the data at Port 2 is held constant at midscale. The effect of this is shown in Figure 33. The IF signal is the image, with respect to the input data rate, of the fundamental. Normally, the $\sin x/x$ response of the DAC will attenuate this image. Zero stuffing improves the passband flatness so that the image amplitude is closer to that of the fundamental signal. Zero stuffing can be an especially useful technique in the synthesis of IF signals.

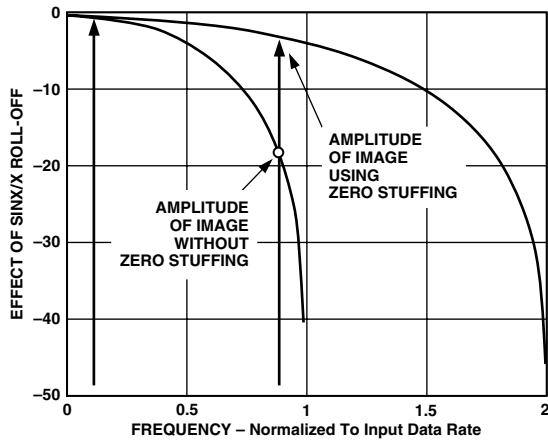

Figure 33. Effects of Pseudo Zero Stuffing on Spectrum of AD9755

EVALUATION BOARD

The AD9755-EB is an evaluation board for the AD9755 TxDAC. Careful attention to layout and circuit design, combined with prototyping area, allows the user to easily and effectively evaluate the AD9755 in different modes of operation.

Referring to Figures 34 and 35, the AD9755's performance can be evaluated differentially or single-endedly using either a transformer, or directly coupling the output. To evaluate the output differentially using the transformer, it is recommended that either the Mini-Circuits T1-1T (through-hole) or the

Coilcraft TTWB-1-B (SMT) be placed in the position of T1 on the evaluation board. To evaluate the output either single-ended or direct-coupled, remove the transformer and bridge either BL1 or BL2.

The digital data to the AD9755 comes from two ribbon cables that interface to the 40-lead IDC connectors P1 and P2. Proper termination or voltage scaling can be accomplished by installing the resistor pack networks RN1–RN12. RN1, 4, 7, 10 are 22 Ω DIP resistor packs and should be installed as they help reduce the digital edge rates and therefore peak current on the inputs.

A single-ended clock can be applied via J3. By setting the SE/DIFF labeled jumpers J2, 3, 4, 6, the input clock can be directed to the CLK+/CLK– inputs of the AD9755 in either a single-ended or differential manner. If a differentially applied clock is desired, a Mini-Circuits T1-1T transformer should be used in the position of T2. Note that with a single-ended square wave clock input, T2 must be removed. A clock can also be applied via the ribbon cable on Port 1 (P1), Pin 33. By inserting the EDGE jumper (JP1), this clock will be applied to the CLK+ input of the AD9755. JP3 should be set in its SE position in this application to bias CLK– to 1/2 the supply voltage.

The AD9755's PLL clock multiplier can be enabled by inserting JP7 in the IN position. As described in the Typical Performance Characteristics and Functional Description sections, with the PLL enabled, a clock at 1/2 the output data rate should be applied as described in the last paragraph. The PLL takes care of the internal 2 \times frequency multiplication and all internal timing requirements. In this application, the PLLLOCK output indicates when lock is achieved on the PLL. With the PLL enabled, the DIV0 and DIV1 jumpers (JP8 and JP9) provide the PLL divider ratio as described in Table I.

The PLL is disabled when JP7 is in the EX setting. In this mode, a clock at the speed of the output data rate must be applied to the clock inputs. Internally, the clock is divided by 2. For data synchronization, a 1 \times clock is provided on the PLLLOCK pin in this application. Care should be taken to read the timing requirements described earlier in the data sheet for optimum performance. With the PLL disabled, the DIV0 and DIV1 jumpers define the mode (interleaved, noninterleaved) as described in Table II.

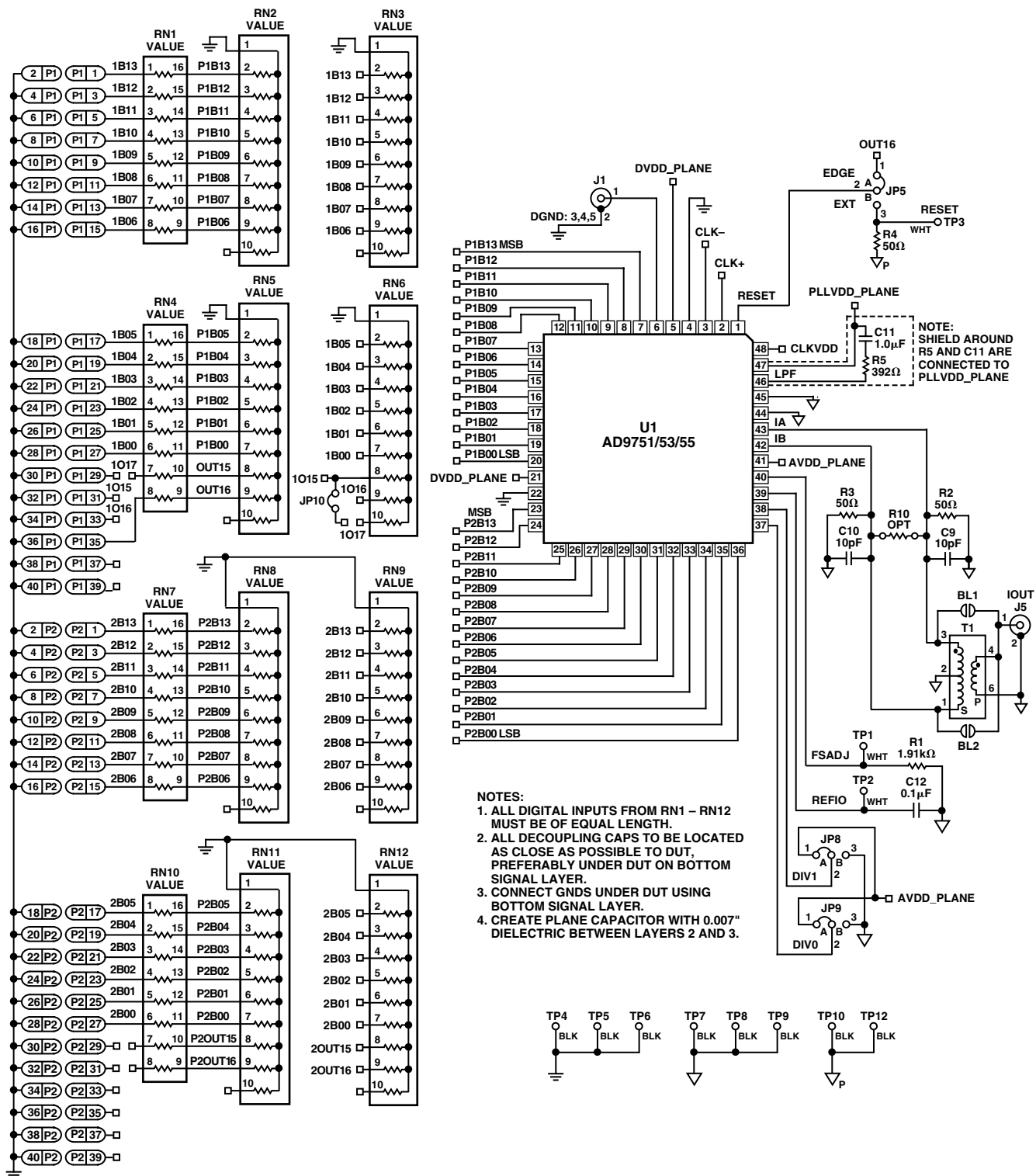

Figure 34. Evaluation Board Circuitry

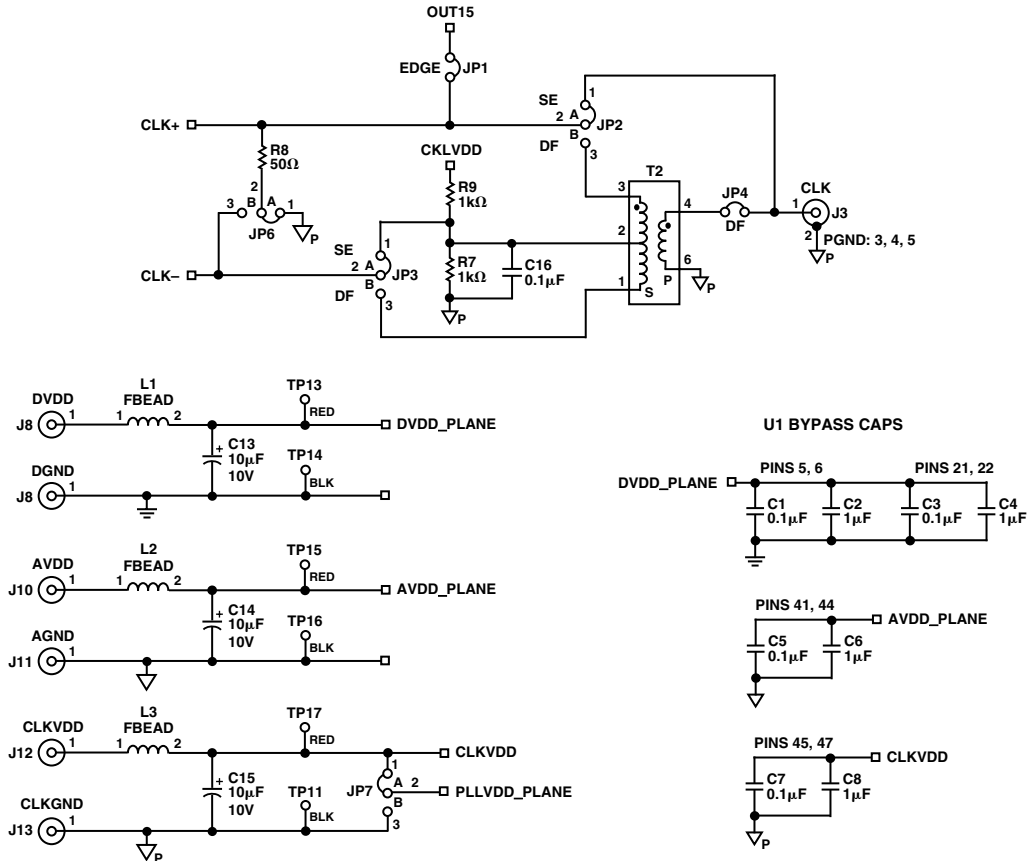

Figure 35. Evaluation Board Clock Circuitry

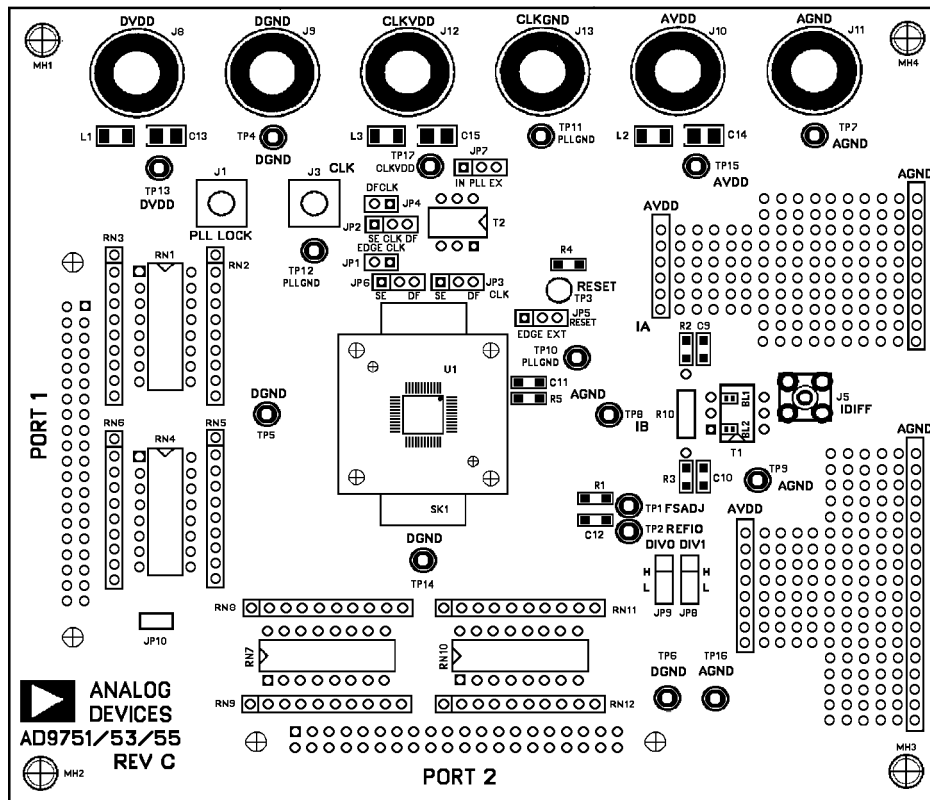

Figure 36. Evaluation Board, Assembly—Top

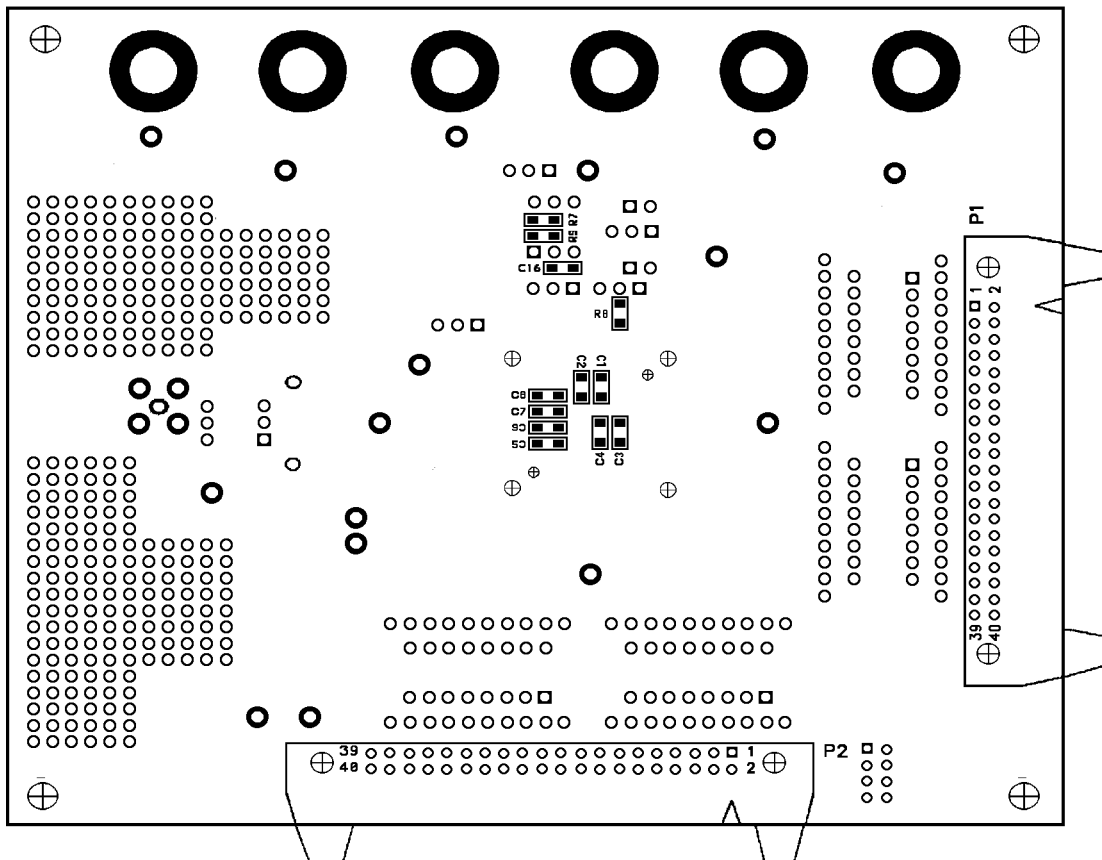

Figure 37. Evaluation Board, Assembly – Bottom

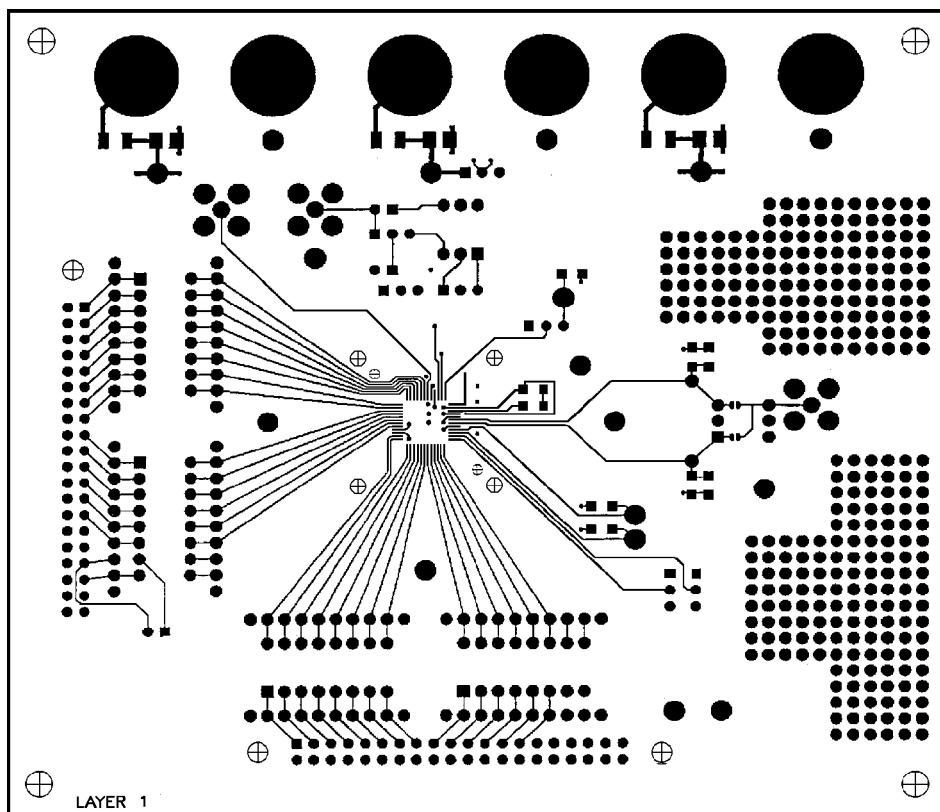

Figure 38. Evaluation Board, Top Layer

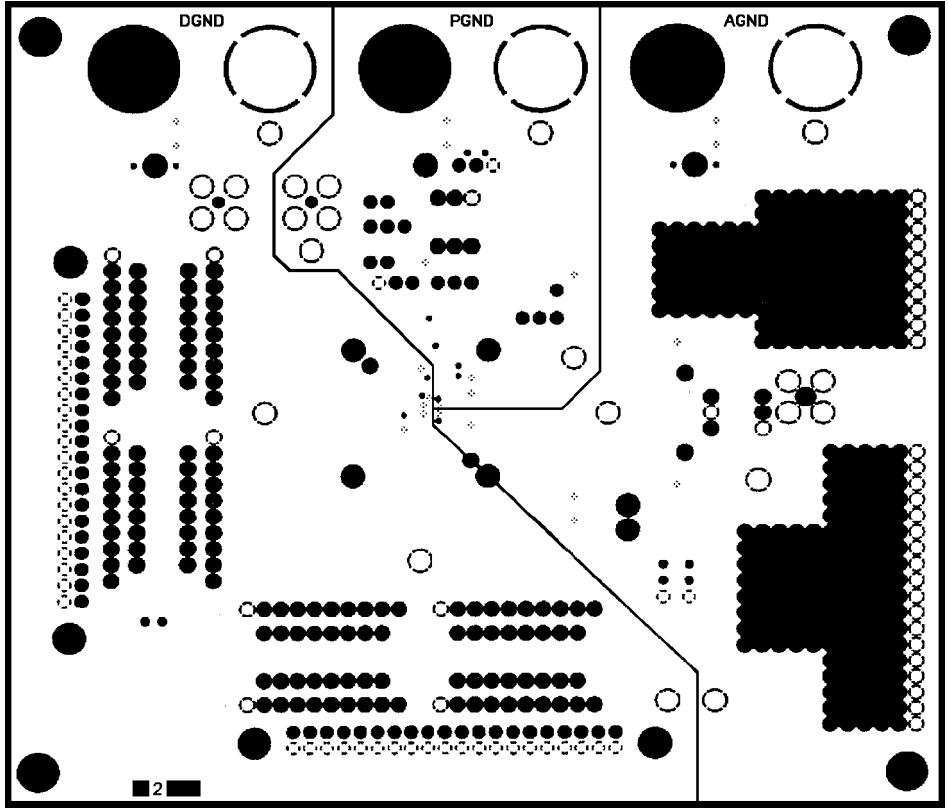

Figure 39. Evaluation Board, Layer 2, Ground Plane

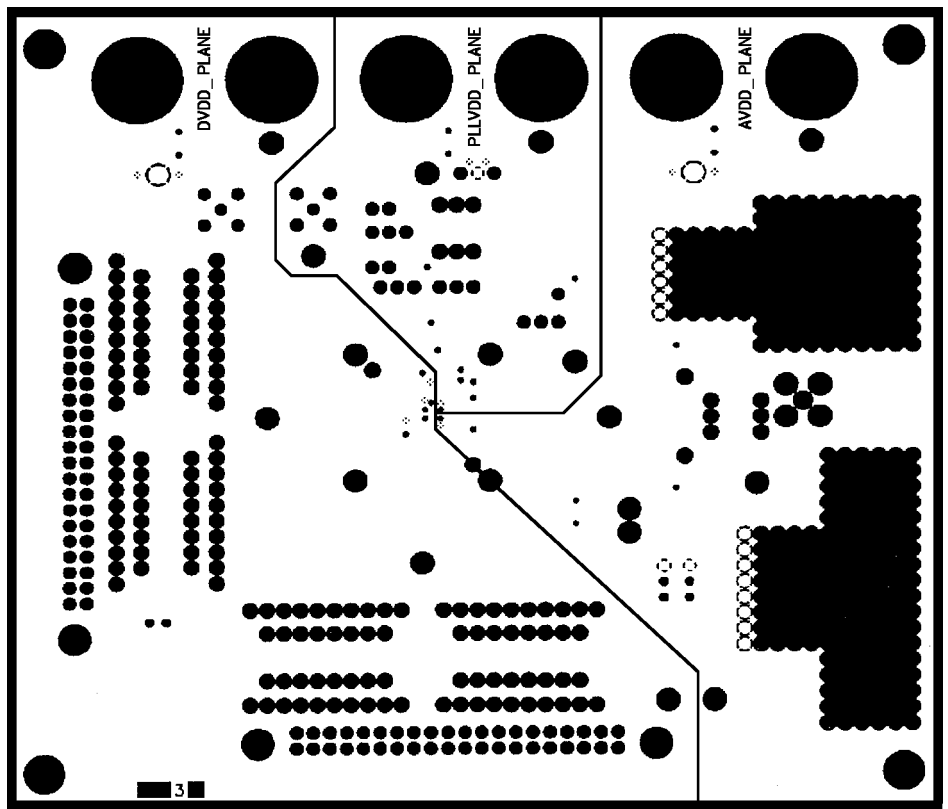

Figure 40. Evaluation Board, Layer 3, Power Plane

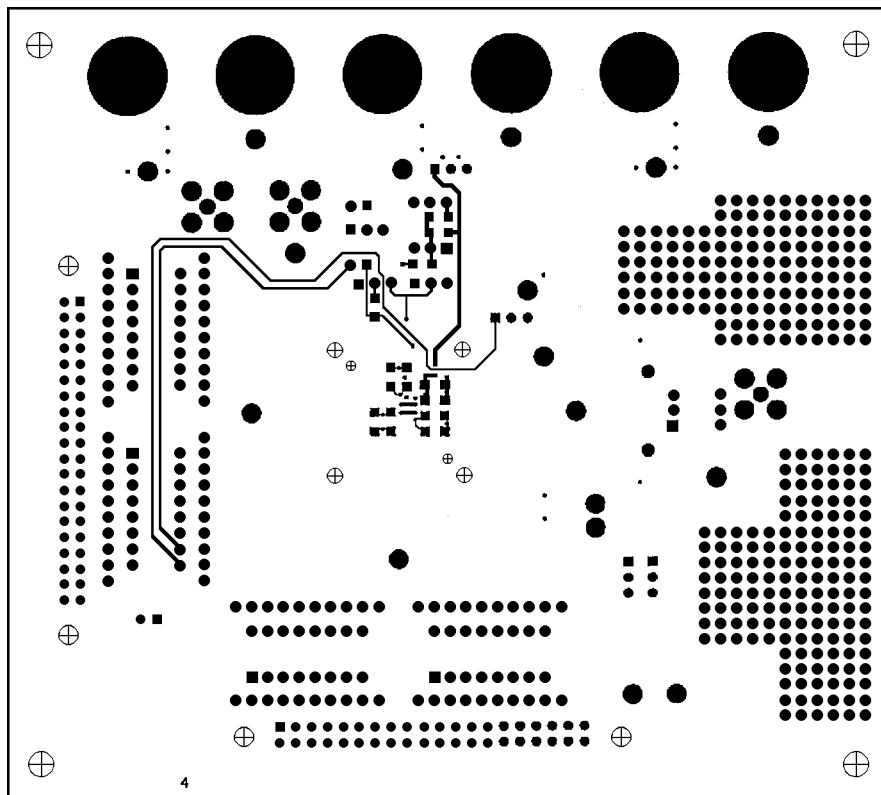

Figure 41. Evaluation Board, Bottom Layer

OUTLINE DIMENSIONS

Dimensions shown in inches and (mm).

48-Lead LQFP Package
(ST-48)

