

AD713

FEATURES

Enhanced Replacement for LF347 and TL084

AC PERFORMANCE

1 μ s Settling to 0.01% for 10 V Step

20 V/ μ s Slew Rate

0.0003% Total Harmonic Distortion (THD)

4 MHz Unity Gain Bandwidth

DC PERFORMANCE

0.5 mV max Offset Voltage (AD713K)

20 μ V/ $^{\circ}$ C max Drift (AD713K)

200 V/mV min Open Loop Gain (AD713K)

2 μ V p-p typ Noise, 0.1 Hz to 10 Hz

True 14-Bit Accuracy

Single Version: AD711, Dual Version: AD712

Available in 16-Pin SOIC, 14-Pin Plastic DIP and

Hermetic Cerdip Packages and in Chip Form

MIL-STD-883B Processing Available

Standard Military Drawing Available

APPLICATIONS

Active Filters

Quad Output Buffers for 12- and 14-Bit DACs

Input Buffers for Precision ADCs

Photo Diode Preamplifier Applications

PRODUCT DESCRIPTION

The AD713 is a quad operational amplifier, consisting of four AD711 BiFET op amps. These precision monolithic op amps offer excellent dc characteristics plus rapid settling times, high slew rates, and ample bandwidths. In addition, the AD713 provides the close matching ac and dc characteristics inherent to amplifiers sharing the same monolithic die.

The single-pole response of the AD713 provides fast settling: 1 μ s to 0.01%. This feature, combined with its high dc precision, makes it suitable for use as a buffer amplifier for 12- or 14-bit DACs and ADCs. It is also an excellent choice for use in active filters in 12-, 14- and 16-bit data acquisition systems. Furthermore, the AD713's low total harmonic distortion (THD) level of 0.0003% and very close matching ac characteristics make it an ideal amplifier for many demanding audio applications.

The AD713 is internally compensated for stable operation at unity gain and is available in seven performance grades. The AD713J and AD713K are rated over the commercial temperature range of 0 $^{\circ}$ C to +70 $^{\circ}$ C. The AD713A and AD713B are rated over the industrial temperature of -40 $^{\circ}$ C to +85 $^{\circ}$ C. The AD713S and AD713T are rated over the military temperature range of -55 $^{\circ}$ C to +125 $^{\circ}$ C and are available processed to MIL-STD-883B, Rev. C.

REV. B

Information furnished by Analog Devices is believed to be accurate and reliable. However, no responsibility is assumed by Analog Devices for its use, nor for any infringements of patents or other rights of third parties which may result from its use. No license is granted by implication or otherwise under any patent or patent rights of Analog Devices.

CONNECTION DIAGRAMS

Plastic (N) and Cerdip (Q) Packages

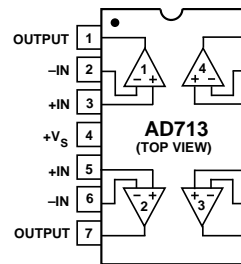

SOIC (R) Package

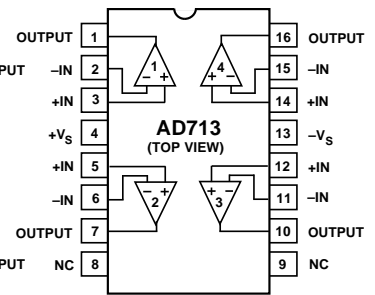

NC = NO CONNECT

The AD713 is offered in a 16-pin SOIC, 14-pin plastic DIP and hermetic cerdip package, or in chip form.

PRODUCT HIGHLIGHTS

1. The AD713 is a high speed BiFET op amp that offers excellent performance at competitive prices. It upgrades the performance of circuits using op amps such as the TL074/TL084, LT1058, LF347 and OPA404.
2. Slew rate is 100% tested for a guaranteed minimum of 16 V/ μ s (J, A and S Grades).
3. The combination of Analog Devices' advanced processing technology, laser wafer drift trimming and well-matched ion-implanted JFETs provides outstanding dc precision. Input offset voltage, input bias current and input offset current are specified in the warmed-up condition and are 100% tested.
4. Very close matching of ac characteristics between the four amplifiers makes the AD713 ideal for high quality active filter applications.

AD713—SPECIFICATIONS ($V_S = \pm 15\text{ V}$ @ $T_A = +25^\circ\text{C}$ unless otherwise noted)

Parameter	Conditions	AD713J/A/S			AD713K/B/T			Units
		Min	Typ	Max	Min	Typ	Max	
INPUT OFFSET VOLTAGE ¹								
Initial Offset	T_{MIN} to T_{MAX}		0.3	1.5		0.2	0.5	mV
Offset vs. Temp				5	2/2/2		0.4	0.7/0.7/1.0
vs. Supply	T_{MIN} to T_{MAX}		78	95		84	100	$\mu\text{V}/^\circ\text{C}$
vs. Supply			76/76/76	95		84	100	dB
Long-Term Stability				15			15	dB
								$\mu\text{V}/\text{Month}$
INPUT BIAS CURRENT ²	$V_{\text{CM}} = 0\text{ V}$		40	150		40	75	pA
	$V_{\text{CM}} = 0\text{ V @ } T_{\text{MAX}}$			3.4/9.6/154			1.7/4.8/77	nA
	$V_{\text{CM}} = \pm 10\text{ V}$		55	200		55	120	pA
INPUT OFFSET CURRENT	$V_{\text{CM}} = 0\text{ V}$		10	75		10	35	pA
	$V_{\text{CM}} = 0\text{ V @ } T_{\text{MAX}}$			1.7/4.8/77			0.8/2.2/36	nA
MATCHING CHARACTERISTICS								
Input Offset Voltage	T_{MIN} to T_{MAX}		0.5	1.8		0.4	0.8	mV
Input Offset Voltage				0.7	2.3/2.3/2.3		0.6	1.0/1.0/1.3
Input Offset Voltage Drift	$f = 1\text{ kHz}$		8			6	25	$\mu\text{V}/^\circ\text{C}$
Input Bias Current			10	100		10	35	pA
Crosstalk		$f = 100\text{ kHz}$			-130			-130
				-95			-95	dB
FREQUENCY RESPONSE								
Small Signal Bandwidth	Unity Gain	3.0	4.0		3.4	4.0		MHz
Full Power Response	$V_O = 20\text{ V p-p}$		200			200		kHz
Slew Rate	Unity Gain	16	20		18	20		V/ μs
Settling Time to 0.01%			1.0	1.2		1.0	1.2	μs
Total Harmonic Distortion	$f = 1\text{ kHz}; R_L \geq 2\text{ k}\Omega;$ $V_O = 3\text{ V rms}$		0.0003			0.0003		%
INPUT IMPEDANCE								
Differential			$3 \times 10^{12} \parallel 5.5$			$3 \times 10^{12} \parallel 5.5$		$\Omega \parallel \text{pF}$
Common Mode			$3 \times 10^{12} \parallel 5.5$			$3 \times 10^{12} \parallel 5.5$		$\Omega \parallel \text{pF}$
INPUT VOLTAGE RANGE								
Differential ³			± 20			± 20		V
Common-Mode Voltage ⁴	T_{MIN} to T_{MAX}		+14.5, -11.5			+14.5, -11.5		V
			-11		+13	-11		+13
Common Mode	$V_{\text{CM}} = \pm 10\text{ V}$	78	88		84	94		dB
Rejection Ratio	T_{MIN} to T_{MAX}	76/76/76	84		82	90		dB
	$V_{\text{CM}} = \pm 11\text{ V}$	72	84		78	90		dB
	T_{MIN} to T_{MAX}	70/70/70	80		74	84		dB
INPUT VOLTAGE NOISE	0.1 Hz to 10 Hz		2			2		$\mu\text{V p-p}$
	$f = 10\text{ Hz}$		45			45		$\text{nV}/\sqrt{\text{Hz}}$
	$f = 100\text{ Hz}$		22			22		$\text{nV}/\sqrt{\text{Hz}}$
	$f = 1\text{ kHz}$		18			18		$\text{nV}/\sqrt{\text{Hz}}$
	$f = 10\text{ kHz}$		16			16		$\text{nV}/\sqrt{\text{Hz}}$
INPUT CURRENT NOISE	$f = 1\text{ kHz}$		0.01			0.01		$\text{pA}/\sqrt{\text{Hz}}$
OPEN-LOOP GAIN	$V_O = \pm 10\text{ V}; R_L \geq 2\text{ k}\Omega$	150	400		200	400		V/mV
	T_{MIN} to T_{MAX}	100/100/100			100			V/mV
OUTPUT CHARACTERISTICS								
Voltage	$R_L \geq 2\text{ k}\Omega$	+13, -12.5	+13.9, -13.3		+13, -12.5	+13.9, -13.3		V
	T_{MIN} to T_{MAX}	$\pm 12/\pm 12/\pm 12$	+13.8, -13.1		± 12	+13.8, -13.1		V
Current	Short Circuit		25			25		mA
POWER SUPPLY								
Rated Performance			± 15			± 15		V
Operating Range		± 4.5		± 18	± 4.5		± 18	V
Quiescent Current			10.0	13.5		10.0	12.0	mA
TRANSISTOR COUNT	# of Transistors		120			120		

NOTES

¹Input Offset Voltage specifications are guaranteed after 5 minutes of operation at $T_A = +25^\circ\text{C}$.

²Bias Current specifications are guaranteed maximum at either input after 5 minutes of operation at $T_A = +25^\circ\text{C}$. For higher temperatures, the current doubles every 10°C .

³Defined as voltage between inputs, such that neither exceeds $\pm 10\text{ V}$ from ground.

⁴Typically exceeding -14.1 V negative common-mode voltage on either input results in an output phase reversal.

Specifications subject to change without notice.

ABSOLUTE MAXIMUM RATINGS^{1, 2}

Supply Voltage	±18 V
Internal Power Dissipation ²	
Input Voltage ³	±18 V
Output Short Circuit Duration (For One Amplifier)	Indefinite
Differential Input Voltage	+V _S and -V _S
Storage Temperature Range (Q)	-65°C to +150°C
Storage Temperature Range (N, R)	-65°C to +125°C
Operating Temperature Range	
AD713J/K	0°C to +70°C
AD713A/B	-40°C to +85°C
AD713S/T	-55°C to +125°C
Lead Temperature Range (Soldering 60 sec)	+300°C

NOTES

¹Stresses above those listed under “Absolute Maximum Ratings” may cause permanent damage to the device. This is a stress rating only and functional operation of the device at these or any other conditions above those indicated in the operational section of this specification is not implied. Exposure to absolute maximum rating conditions for extended periods may affect device reliability.

²Thermal Characteristics:

14-Pin Plastic Package:	$\theta_{JC} = 30^{\circ}\text{C/Watt}; \theta_{JA} = 100^{\circ}\text{C/Watt}$
14-Pin Cerdip Package:	$\theta_{JC} = 30^{\circ}\text{C/Watt}; \theta_{JA} = 110^{\circ}\text{C/Watt}$
16-Pin SOIC Package:	$\theta_{JC} = 30^{\circ}\text{C/Watt}; \theta_{JA} = 100^{\circ}\text{C/Watt}$

³For supply voltages less than ±18 V, the absolute maximum input voltage is equal to the supply voltage.

ORDERING GUIDE

Model	Temperature Range	Package Description	Package Option*
AD713AQ	-40°C to +85°C	14-Pin Ceramic DIP	Q-14
AD713BQ	-40°C to +85°C	14-Pin Ceramic DIP	Q-14
AD713JCHIPS	0°C to +70°C	Bare Die	
AD713JN	0°C to +70°C	14-Pin Plastic DIP	N-14
AD713JR-16	0°C to +70°C	16-Pin Plastic SOIC	R-16
AD713JR-16-REEL	0°C to +70°C	16-Pin Plastic SOIC	R-16
AD713JR-16-REEL7	0°C to +70°C	16-Pin Plastic SOIC	R-16
AD713KN	0°C to +70°C	14-Pin Plastic DIP	N-14
AD713SCHIPS	-55°C to +125°C	Bare Die	
AD713SQ	-55°C to +125°C	14-Pin Ceramic DIP	Q-14
AD713SQ/883B	-55°C to +125°C	14-Pin Ceramic DIP	Q-14
AD713TQ	-55°C to +125°C	14-Pin Ceramic DIP	Q-14
AD713TQ/883B	-55°C to +125°C	14-Pin Ceramic DIP	Q-14
5962-9063301MCA	-55°C to +125°C	14-Pin Ceramic DIP	Q-14
5962-9063302MCA	-55°C to +125°C	14-Pin Ceramic DIP	Q-14

*N = Plastic DIP; Q = Cerdip; R = Small Outline IC (SOIC).

METALIZATION PHOTOGRAPH

Dimensions shown in inches and (mm).
Contact factory for latest dimensions.

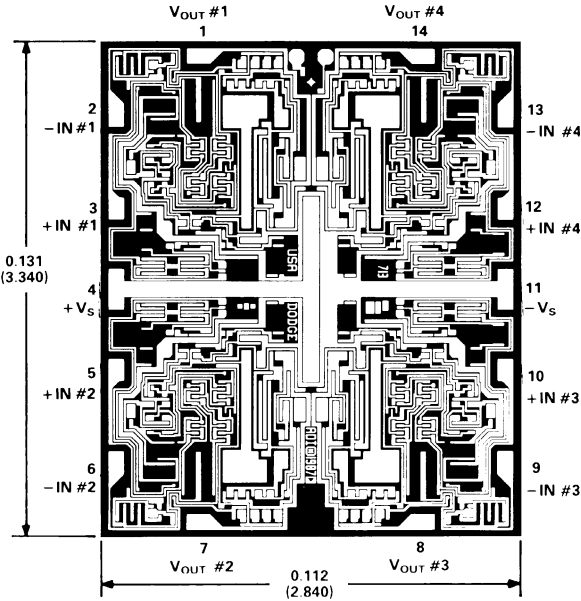

AD713—Typical Characteristics

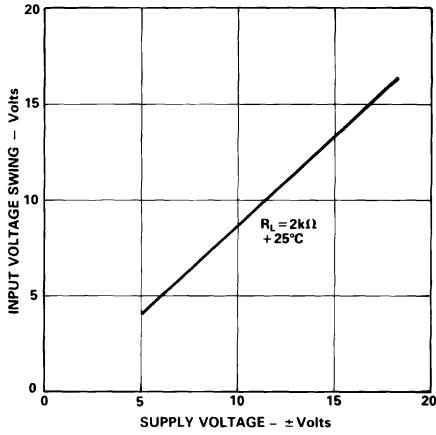

Figure 1. Input Voltage Swing vs. Supply Voltage

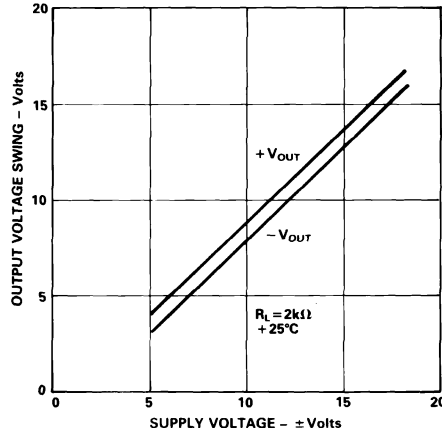

Figure 2. Output Voltage Swing vs. Supply Voltage

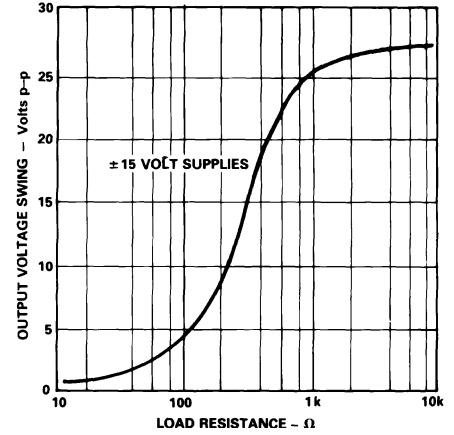

Figure 3. Output Voltage Swing vs. Load Resistance

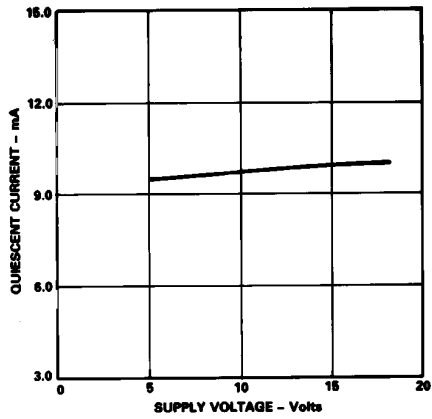

Figure 4. Quiescent Current vs. Supply Voltage

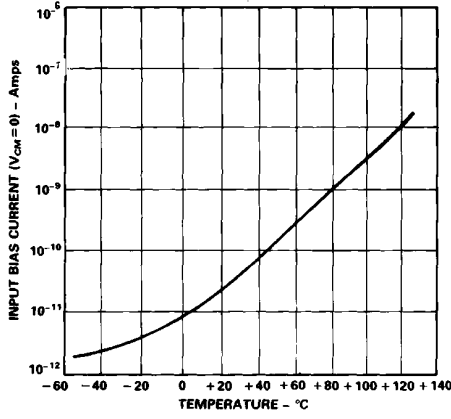

Figure 5. Input Bias Current vs. Temperature

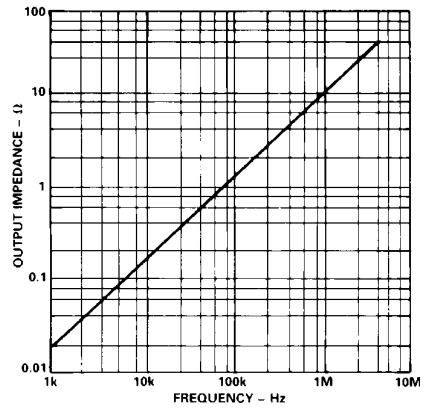

Figure 6. Output Impedance vs. Frequency, $G = 1$

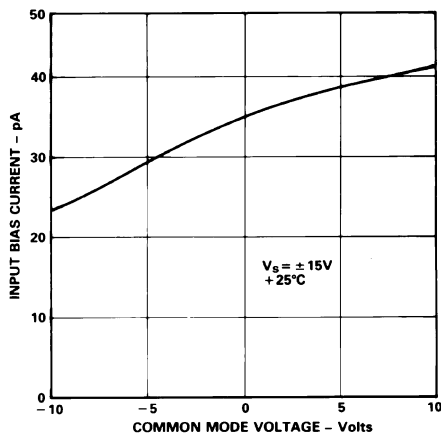

Figure 7. Input Bias Current vs. Common Mode Voltage

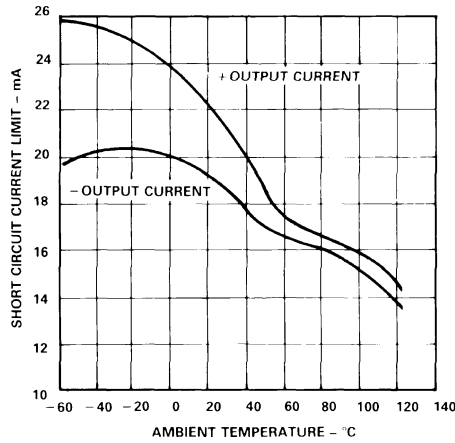

Figure 8. Short Circuit Current Limit vs. Temperature

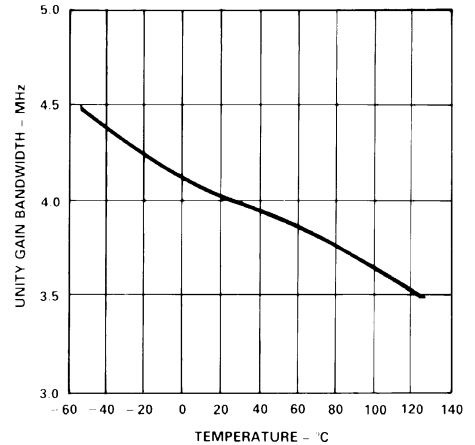

Figure 9. Gain Bandwidth Product vs. Temperature

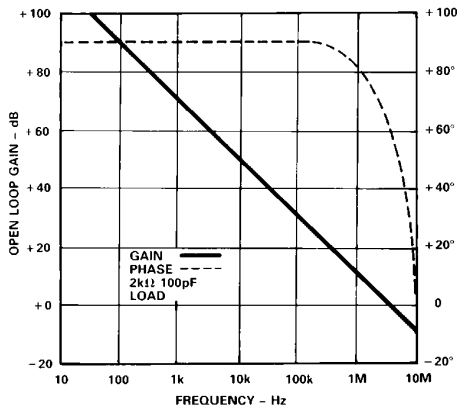

Figure 10. Open-Loop Gain and Phase Margin vs. Frequency

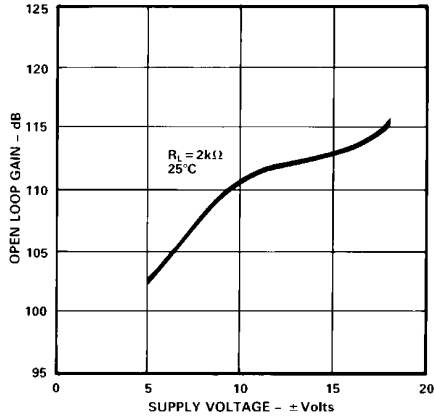

Figure 11. Open-Loop Gain vs. Supply Voltage

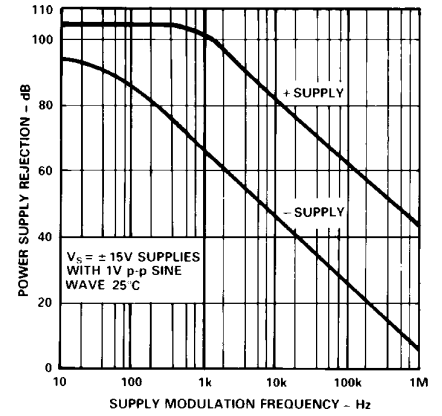

Figure 12. Power Supply Rejection vs. Frequency

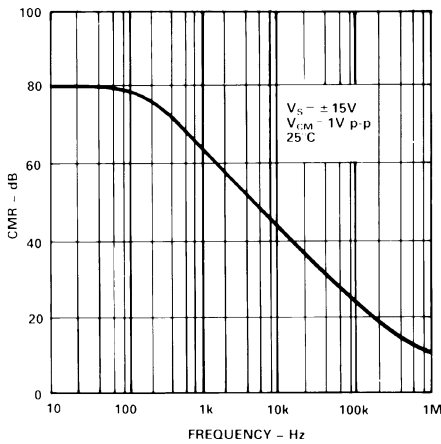

Figure 13. Common Mode Rejection vs. Frequency

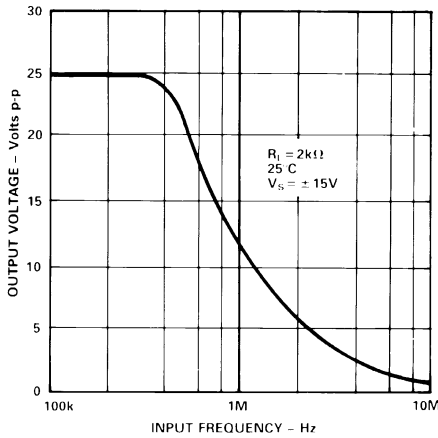

Figure 14. Large Signal Frequency Response

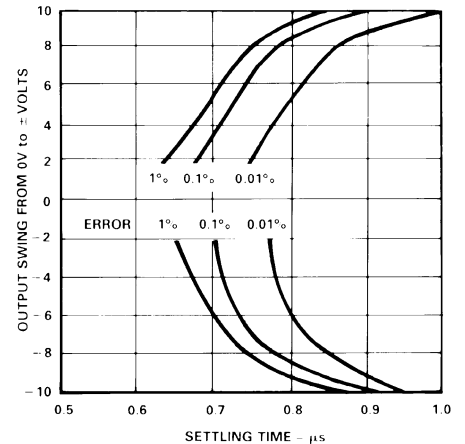

Figure 15. Output Swing and Error vs. Settling Time

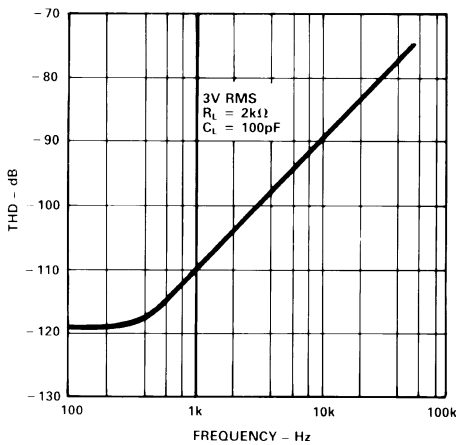

Figure 16. Total Harmonic Distortion vs. Frequency

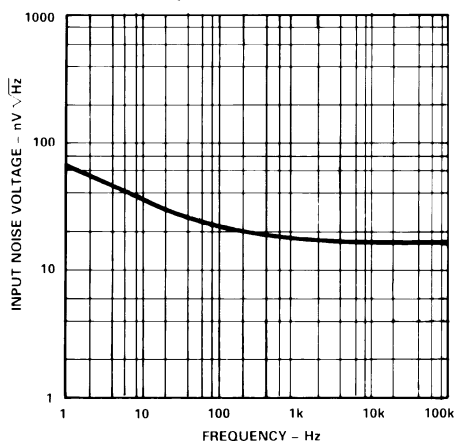

Figure 17. Input Noise Voltage Spectral Density

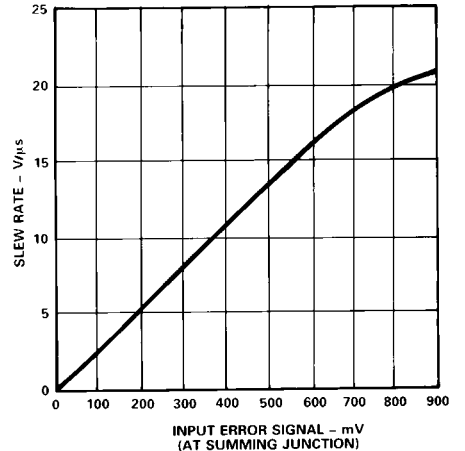
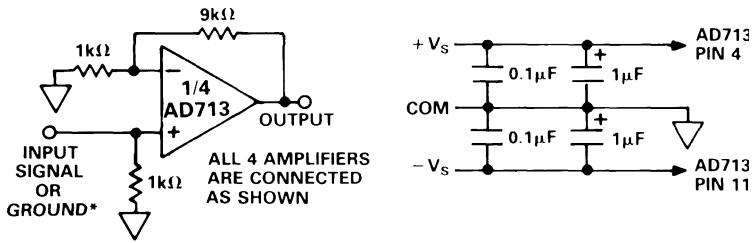

Figure 18. Slew Rate vs. Input Error Signal

AD713



*THE SIGNAL INPUT (1kHz SINEWAVE, 2V p-p) IS APPLIED TO ONE AMPLIFIER AT A TIME. THE OUTPUTS OF THE OTHER THREE AMPLIFIERS ARE THEN MEASURED FOR CROSSTALK.

Figure 19. Crosstalk Test Circuit

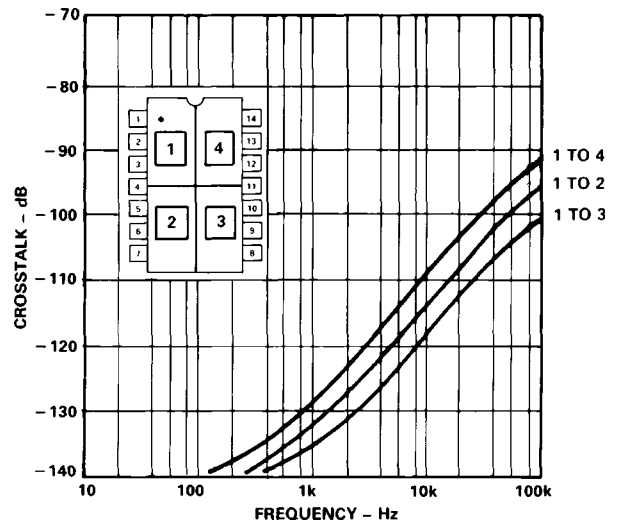

Figure 20. Crosstalk vs. Frequency

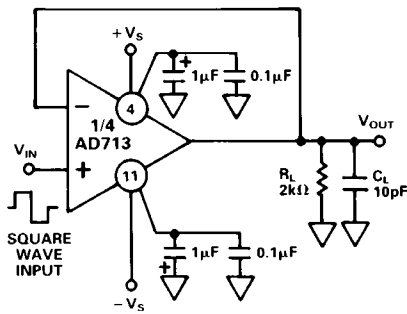

Figure 21a. Unity Gain Follower

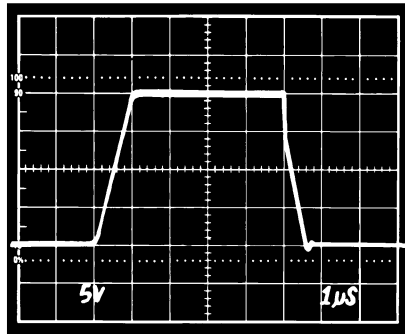

Figure 21b. Unity Gain Follower Pulse Response (Large Signal)

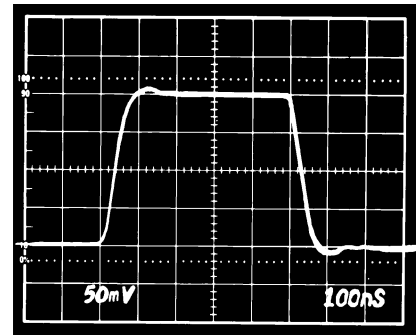

Figure 21c. Unity Gain Follower Pulse Response (Small Signal)

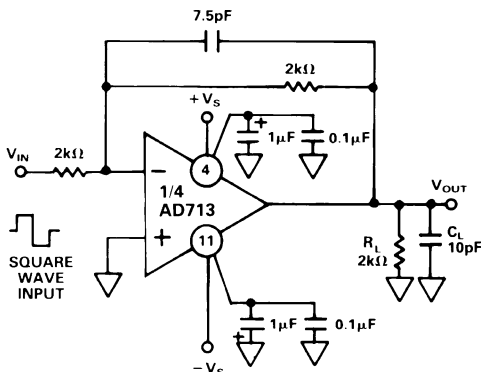

Figure 22a. Unity Gain Inverter

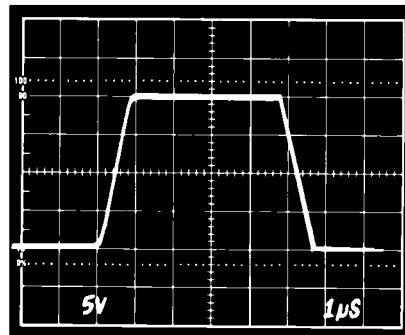

Figure 22b. Unity Gain Inverter Pulse Response (Large Signal)

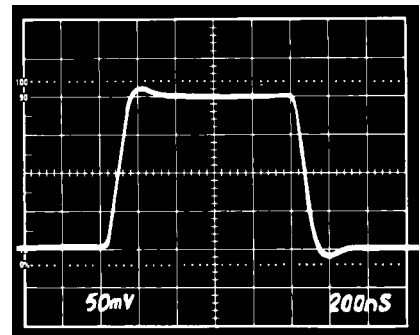

Figure 22c. Unity Gain Inverter Pulse Response (Small Signal)

MEASURING AD713 SETTLING TIME

The photos of Figures 24 and 25 show the dynamic response of the AD713 while operating in the settling time test circuit of Figure 23. The input of the settling time fixture is driven by a flat-top pulse generator. The error signal output from the false summing node of A1, the AD713 under test, is clamped, amplified by op amp A2 and then clamped again.

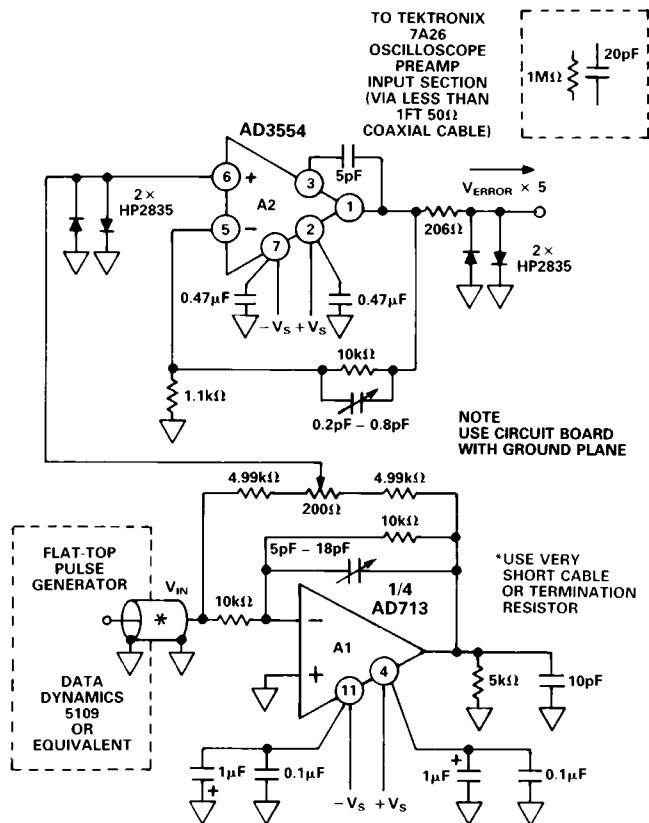

Figure 23. Settling Time Test Circuit

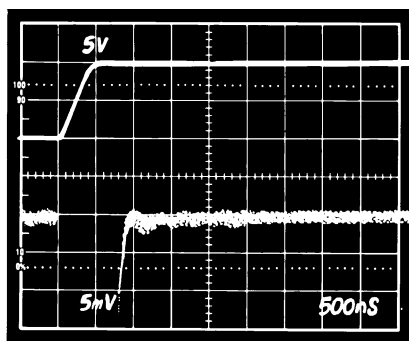

Figure 24. Settling Characteristics 0 V to +10 V Step. Upper Trace: Output of AD713 Under Test (5 V/div). Lower Trace: Amplified Error Voltage (0.01%/div)

The error signal is thus clamped twice: once to prevent overloading amplifier A2 and then a second time to avoid overloading the oscilloscope preamp. A Tektronix oscilloscope preamp type 7A26 was carefully chosen because it recovers from the approximately 0.4 volt overload quickly enough to allow accurate measurement of the AD713's 1 μs settling time. Amplifier A2 is a very high speed FET input op amp; it provides a voltage gain of 10, amplifying the error signal output of the AD713 under test (providing an overall gain of 5).

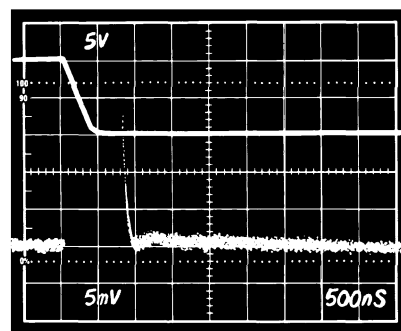

Figure 25. Settling Characteristics to -10 V Step. Upper Trace: Output of AD713 Under Test (5 V/div). Lower Trace: Amplified Error Voltage (0.01%/div)

POWER SUPPLY BYPASSING

The power supply connections to the AD713 must maintain a low impedance to ground over a bandwidth of 4 MHz or more. This is especially important when driving a significant resistive or capacitive load, since all current delivered to the load comes from the power supplies. Multiple high quality bypass capacitors are recommended for each power supply line in any critical application. A 0.1 μF ceramic and a 1 μF electrolytic capacitor as shown in Figure 26 placed as close as possible to the amplifier (with short lead lengths to power supply common) will assure adequate high frequency bypassing in most applications. A minimum bypass capacitance of 0.1 μF should be used for any application.

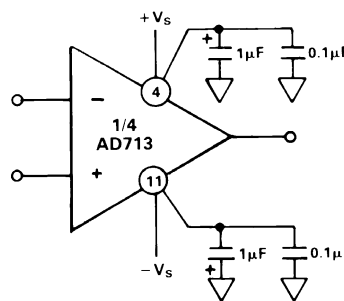

Figure 26. Recommended Power Supply Bypassing

AD713

A HIGH SPEED INSTRUMENTATION AMPLIFIER CIRCUIT

The instrumentation amplifier circuit shown in Figure 27 can provide a range of gains from unity up to 1000 and higher using only a single AD713. The circuit bandwidth is 1.2 MHz at a gain of 1 and 250 kHz at a gain of 10; settling time for the entire circuit is less than 5 μ s to within 0.01% for a 10 volt step, ($G = 10$). Other uses for amplifier A4 include an active data guard and an active sense input.

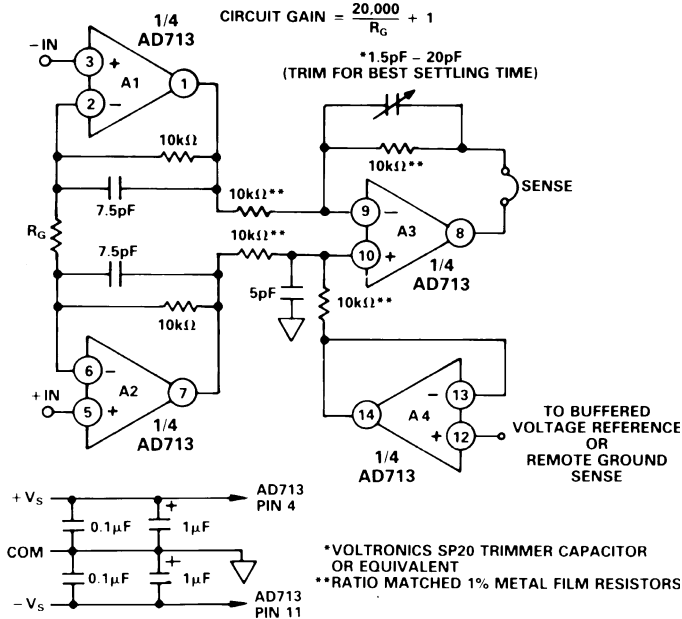

Figure 27. A High Speed Instrumentation Amplifier Circuit

Table I provides a performance summary for this circuit. The photo of Figure 28 shows the pulse response of this circuit for a gain of 10.

Table I. Performance Summary for the High Speed Instrumentation Amplifier Circuit

Gain	R_G	Bandwidth	T Settle (0.01%)
1	NC	1.2 MHz	2 μ s
2	20 k Ω	1.0 MHz	2 μ s
10	4.04 k Ω	0.25 MHz	5 μ s

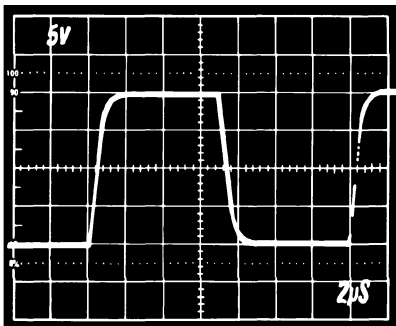

Figure 28. The Pulse Response of the High Speed Instrumentation Amplifier. Gain = 10

A HIGH SPEED FOUR OP AMP CASCADED AMPLIFIER CIRCUIT

Figure 29 shows how the four amplifiers of the AD713 may be connected in cascade to form a high gain, high bandwidth amplifier. This gain of 100 amplifier has a -3 dB bandwidth greater than 600 kHz.

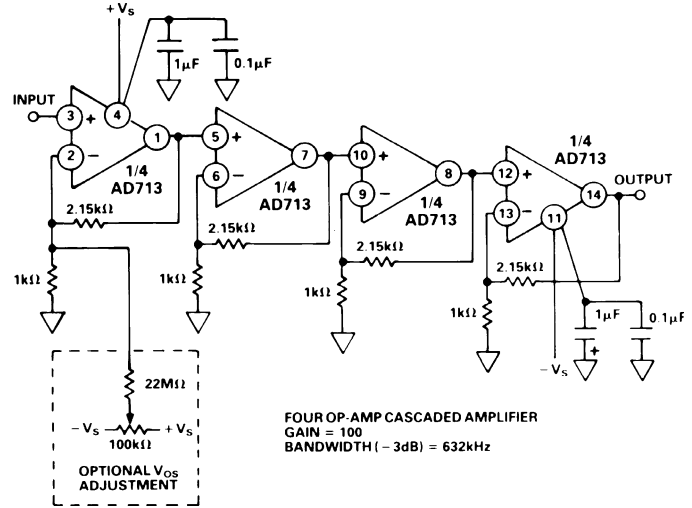

Figure 29. A High Speed Four Op Amp Cascaded Amplifier Circuit

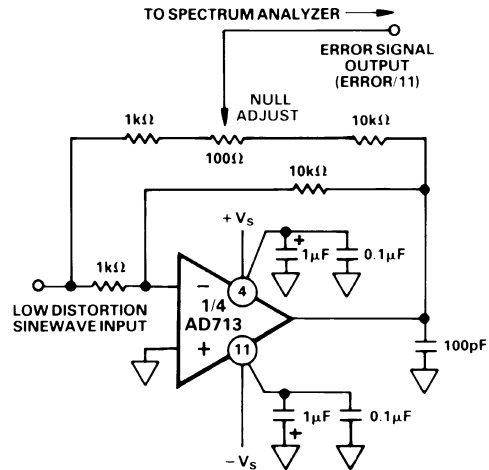

Figure 30. THD Test Circuit

HIGH SPEED OP AMP APPLICATIONS AND TECHNIQUES

DAC Buffers (I-to-V Converters)

The wide input dynamic range of JFET amplifiers makes them ideal for use in both waveform reconstruction and digital-audio DAC applications. The AD713, in conjunction with the AD1860 DAC, can achieve 0.0016% THD (here at a 4fs or a 176.4 kHz update rate) without requiring the use of a deglitcher. Just such a circuit is shown in Figure 31. The 470 pF feedback capacitor used with IC2a, along with op amp IC2b and its associated components, together form a 3-pole low-pass filter. Each or all of these poles can be tailored for the desired attenuation and phase characteristics required for a particular application. In this application, one half of an AD713 serves each channel in a two-channel stereo system.

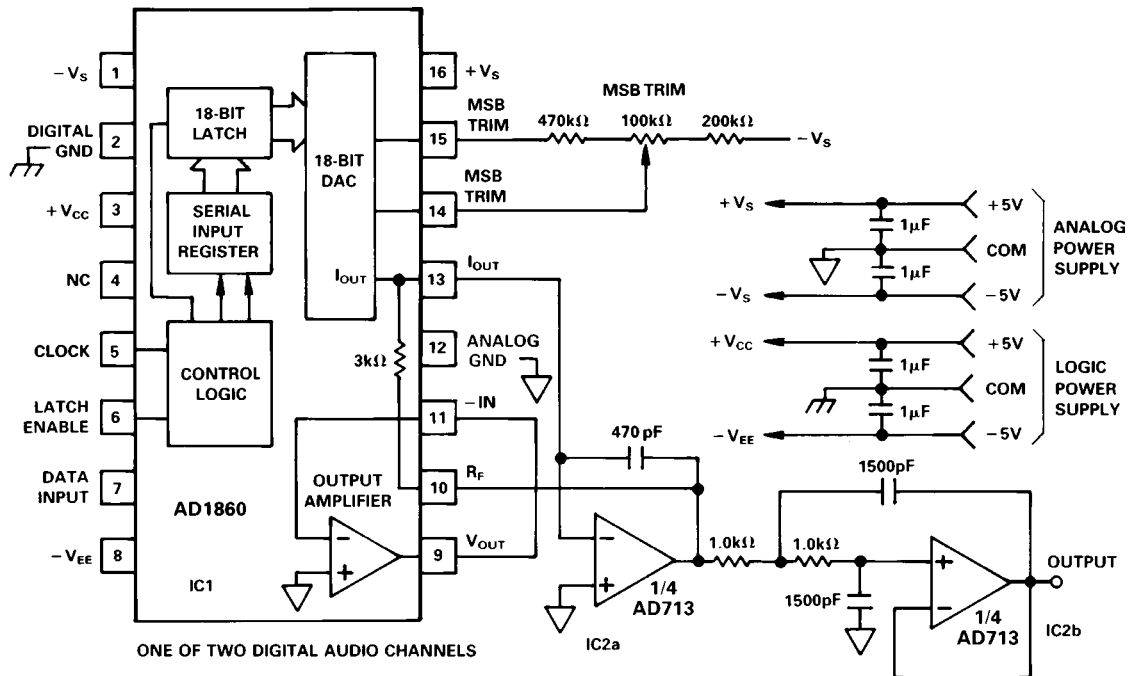

Figure 31. A D/A Converter Circuit for Digital Audio

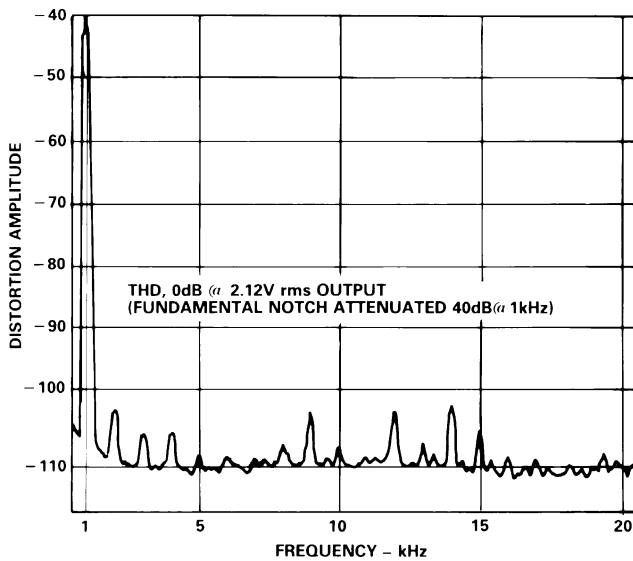

Figure 32. Harmonic Distortion as Frequency for the Digital Audio Circuit of Figure 31

Driving the Analog Input of an A/D Converter

An op amp driving the analog input of an A/D converter, such as that shown in Figure 33, must be capable of maintaining a constant output voltage under dynamically changing load conditions. In successive approximation converters, the input current is compared to a series of switched trial currents. The comparison point is diode clamped but may vary by several hundred millivolts, resulting in high frequency modulation of the A/D input current. The output impedance of a feedback amplifier is made artificially low by its loop gain. At high frequencies, where the loop gain is low, the amplifier output impedance can approach its open loop value.

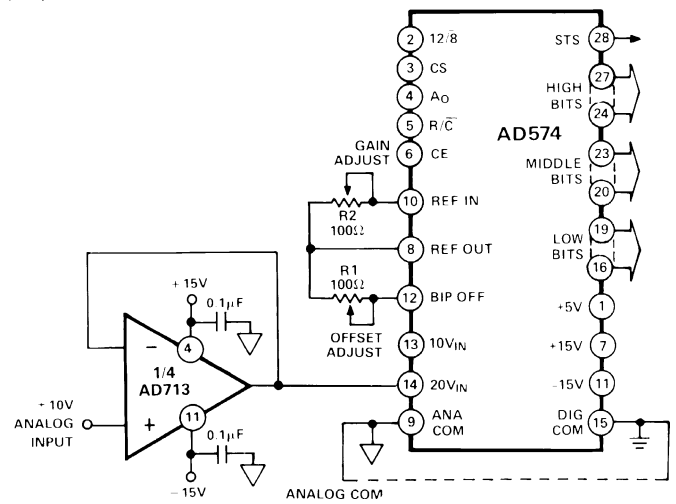

Figure 33. The AD713 as an ADC Buffer

Most IC amplifiers exhibit a minimum open loop output impedance of 25 Ω, due to current limiting resistors. A few hundred microamps reflected from the change in converter loading can introduce errors in instantaneous input voltage. If the A/D conversion speed is not excessive and the bandwidth of the amplifier is sufficient, the amplifier's output will return to the nominal value before the converter makes its comparison. However, many amplifiers have relatively narrow bandwidths, yielding slow recovery from output transients. The AD713 is ideally suited as a driver for A/D converters since it offers both a wide bandwidth and a high open loop gain.

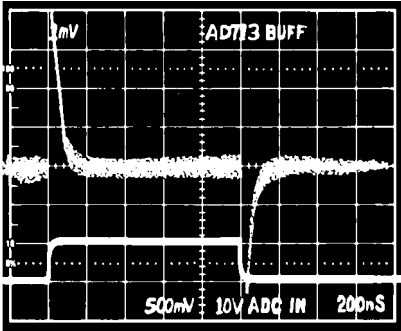

Figure 34. Buffer Recovery Time Source Current = 2 mA

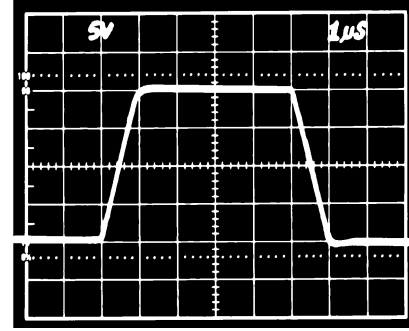

Figure 37. Transient Response, $R_L = 2\text{ k}\Omega$, $C_L = 500\text{ pF}$

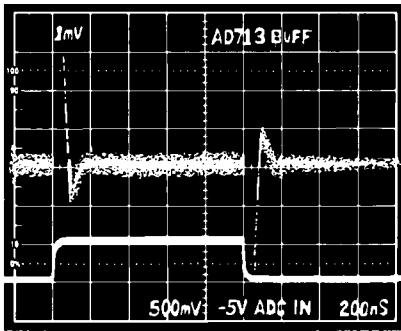

Figure 35. Buffer Recovery Time Sink Current = 1 mA

Driving A Large Capacitive Load

The circuit of Figure 36 employs a 100 Ω isolation resistor which enables the amplifier to drive capacitive loads exceeding 1500 pF; the resistor effectively isolates the high frequency feedback from the load and stabilizes the circuit. Low frequency feedback is returned to the amplifier summing junction via the low pass filter formed by the 100 Ω series resistor and the load capacitance, C1. Figure 37 shows a typical transient response for this connection.

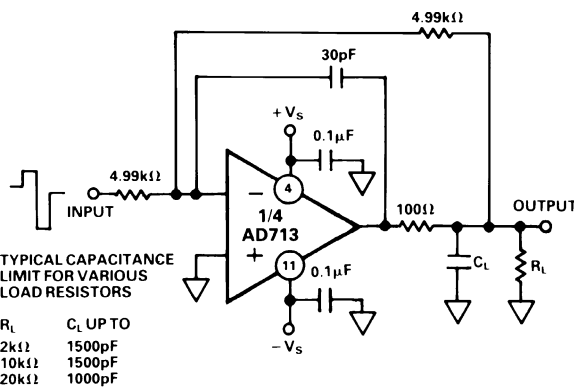

Figure 36. Circuit for Driving a Large Capacitance Load

Table II. Recommended Trim Resistor Values vs. Grades for AD7545 for $V_D = +5\text{ V}$

Trim Resistor	JN/AQ/SD	KN/BQ/TD	LN/CQ/UD	GLN/GCQ/GUD
R1	500 Ω	200 Ω	100 Ω	20 Ω
R2	150 Ω	68 Ω	33 Ω	6.8 Ω

CMOS DAC APPLICATIONS

The AD713 is an excellent output amplifier for CMOS DACs. It can be used to perform both 2 and 4 quadrant operation. The output impedance of a DAC using an inverted R-2R ladder approaches R for codes containing many “1”s, 3R for codes containing a single “1” and infinity for codes containing all zeros.

For example, the output resistance of the AD7545 will modulate between 11 k Ω and 33 k Ω . Therefore, with the DAC’s internal feedback resistance of 11 k Ω , the noise gain will vary from 2 to 4/3. This changing noise gain modulates the effect of the input offset voltage of the amplifier, resulting in nonlinear DAC amplifier performance. The AD713, with its guaranteed 1.5 mV input offset voltage, minimizes this effect achieving 12-bit performance.

Figures 38 and 39 show the AD713 and a 12-bit CMOS DAC, the AD7545, configured for either a unipolar binary (2-quadrant multiplication) or bipolar (4-quadrant multiplication) operation. Capacitor C1 provides phase compensation which reduces overshoot and ringing.

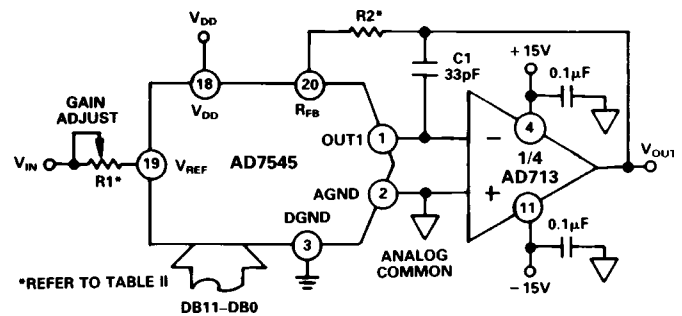

Figure 38. Unipolar Binary Operation

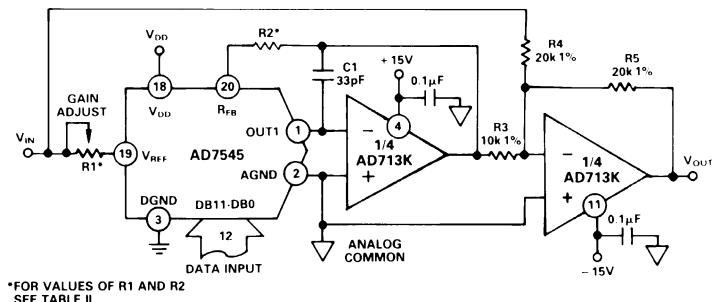

Figure 39. Bipolar Operation

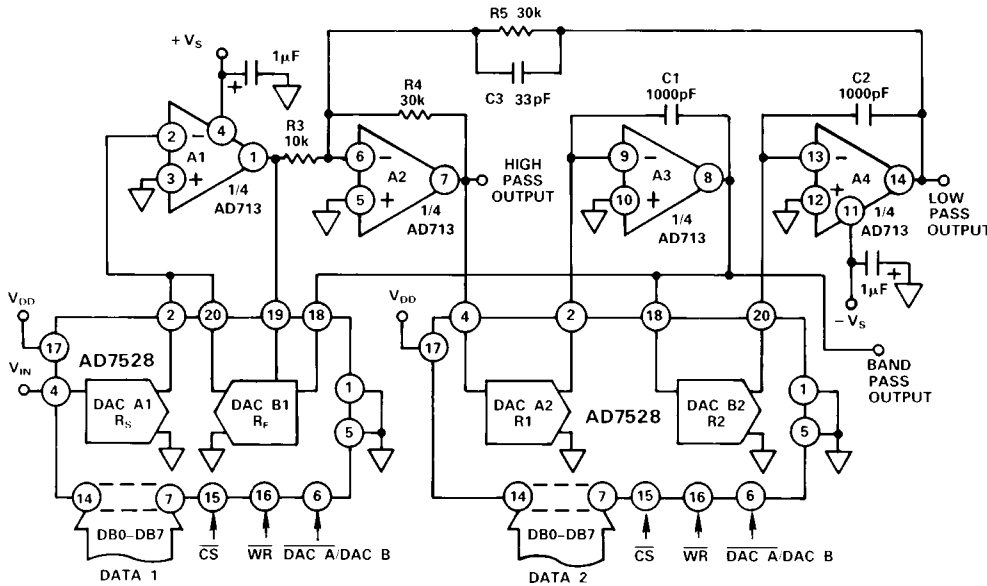

Figure 40. A Programmable State Variable Filter Circuit

FILTER APPLICATIONS

A Programmable State Variable Filter

For the state variable or universal filter configuration of Figure 40 to function properly, DACs A1 and B1 need to control the gain and Q of the filter characteristic, while DACs A2 and B2 must accurately track for the simple expression of f_c to be true. This is readily accomplished using two AD7528 DACs and one AD713 quad op amp. Capacitor C3 compensates for the effects of op amp gain-bandwidth limitations.

This filter provides low pass, high pass and band pass outputs and is ideally suited for applications where microprocessor control of filter parameters is required. The programmable range for component values shown is $f_c = 0$ to 15 kHz and $Q = 0.3$ to 4.5.

GIC and FDNR FILTER APPLICATIONS

The closely matched and uniform ac characteristics of the AD713 make it ideal for use in GIC (gyrator) and FDNR (frequency dependent negative resistor) filter applications. Figures

41 and 43 show the AD713 used in two typical active filters. The first shows a single AD713 simulating two coupled inductors configured as a one-third octave bandpass filter. A single section of this filter meets ANSI class II specifications and handles a 7.07 V rms signal with <0.002% THD (20 Hz–20 kHz).

Figure 43 shows a 7-pole antialiasing filter for a $2 \times$ oversampling (88.2 kHz) digital audio application. This filter has <0.05 dB pass band ripple and $19.8 \pm 0.3 \mu s$ delay, dc–20 kHz and will handle a 5 V rms signal ($V_s = \pm 15$ V) with no overload at any internal nodes.

The filter of Figure 41 can be scaled for any center frequency by using the formula:

$$f_c = \frac{1.11}{2\pi RC}$$

where all resistors and capacitors scale equally. Resistors R3–R8 should not be greater than 2 k Ω in value, to prevent parasitic oscillations caused by the amplifier’s input capacitance.

CIRCUIT EQUATIONS

$$C_1 = C_2, R_1 = R_2, R_4 = R_5$$

$$f_c = \frac{1}{2\pi R_1 C_1}$$

$$Q = \frac{R_3}{R_4} \cdot \frac{R_f}{R_{FBB1}}$$

$$A_o = - \frac{R_f}{R_s}$$

Note:
DAC equivalent resistance equals $256 \times (\text{DAC Ladder resistance})$
DAC Digital Code

$$f_c = \frac{1.11}{2\pi RC}$$

$$C_1 = C_2 = C_3 = C_4 = C$$

$$R_1 = R_2 = 4.76R$$

$$R_{11} = 4.32R$$

$$R_3 = R_4 = R_5 = R_6 = R_7 = R_8 = R_9 = R_{10} = R$$

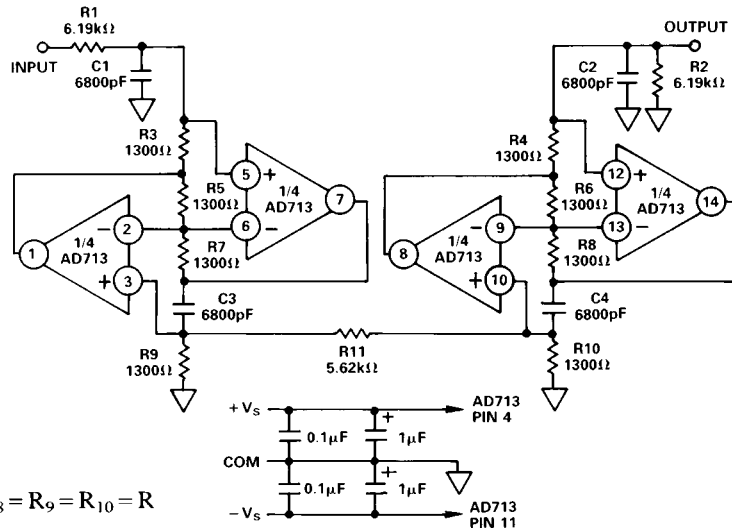

Figure 41. A 1/3 Octave Filter Circuit

AD713

If this is not practical, small lead capacitances (10–20 pF) should be added across R5 and R6. Figures 42 and 44 show the output amplitude vs. frequency of these filters.

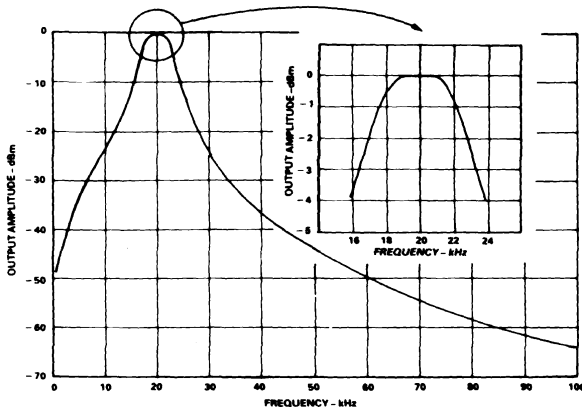

Figure 42. Output Amplitude vs. Frequency of 1/3 Octave Filter

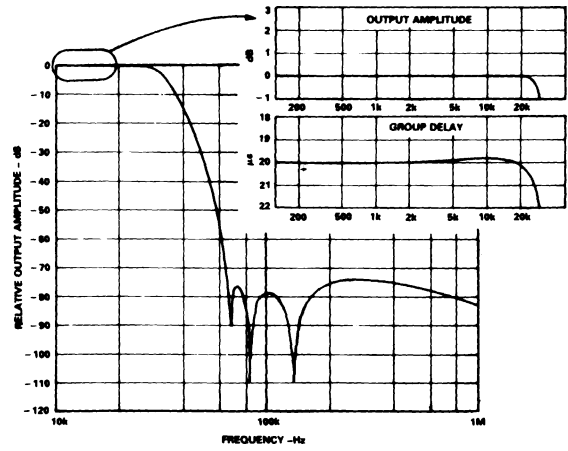

Figure 44. Relative Output Amplitude vs. Frequency of Antialiasing Filter

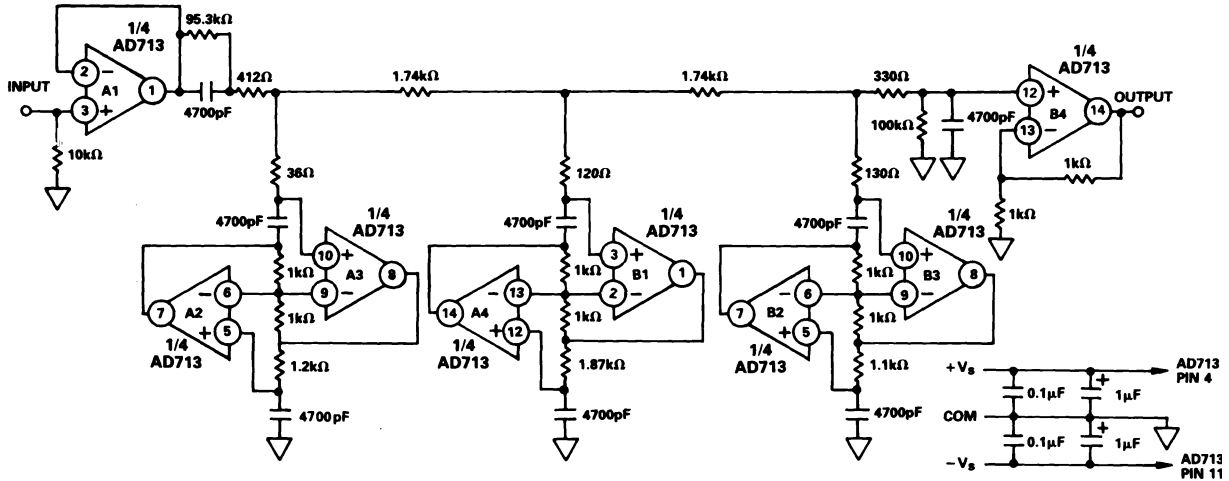
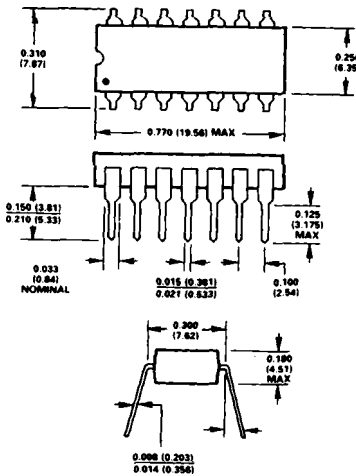

Figure 43. An Antialiasing Filter

OUTLINE DIMENSIONS

Dimensions shown in inches and (mm).

14-Pin Plastic (N-14A) DIP Package



14-Pin Cerdip (Q-14) Package

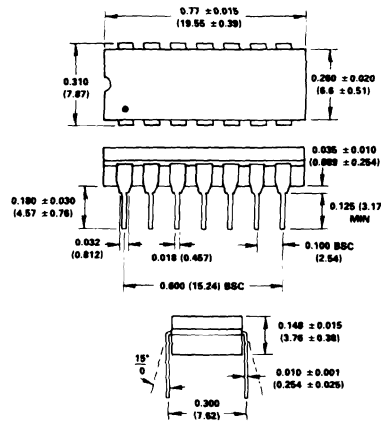

16-Pin SOIC (R-16) Package

