



Ultralow Power, +3.3 V, RS-232 Notebook PC Serial Port Drivers/Receivers

ADM560/ADM561

FEATURES

- RS-232 Compatible
- Operates with 3 V or 5 V Logic
- Ultralow Power CMOS: 1.3 mA Operation
- Low Power Shutdown: 0.2 μ A
- Suitable for Serial Port Mice
- 116 kbits/s Data Rate
- 1 μ F Charge Pump Capacitors
- Single +3 V to +3.6 V Power Supply
- Two Receivers Active in Shutdown (ADM560)

APPLICATIONS

- Laptop Computers
- Palmtop Computers
- Notebook Computers
- Peripherals
- Modems
- Printers
- Battery Operated Equipment

GENERAL DESCRIPTION

The ADM560/ADM561 are four driver/five receiver interface devices designed to meet the EIA-232 standard while operating with a single +3.3 V power supply. The devices feature an on-board dc-to-dc converter, eliminating the need for dual ± 5 V power supplies. This dc-dc converter contains a voltage doubler and voltage inverter which internally generates ± 6.6 V from the input +3.3 V power supply.

The ADM560 and ADM561 consume only 5 mW making them ideally suited for battery and other power-sensitive applications. A shutdown facility is also provided which reduces the power to 0.66 μ W.

The ADM560 contains active low shutdown and active high receiver enable signals. In shutdown mode, two receivers remain active thereby allowing monitoring of peripheral devices. This feature allows the device to be shut down until a peripheral device begins communication. The active receivers can alert the processor which can then take the ADM560 out of the shutdown mode.

The ADM561 features active high shutdown and an active low receiver enable. In this device all receivers are disabled in shutdown.

The ADM560/ADM561 is fabricated using CMOS technology for minimal power consumption. It features a high level of over-voltage protection and latch-up immunity. The receiver inputs

FUNCTIONAL BLOCK DIAGRAM

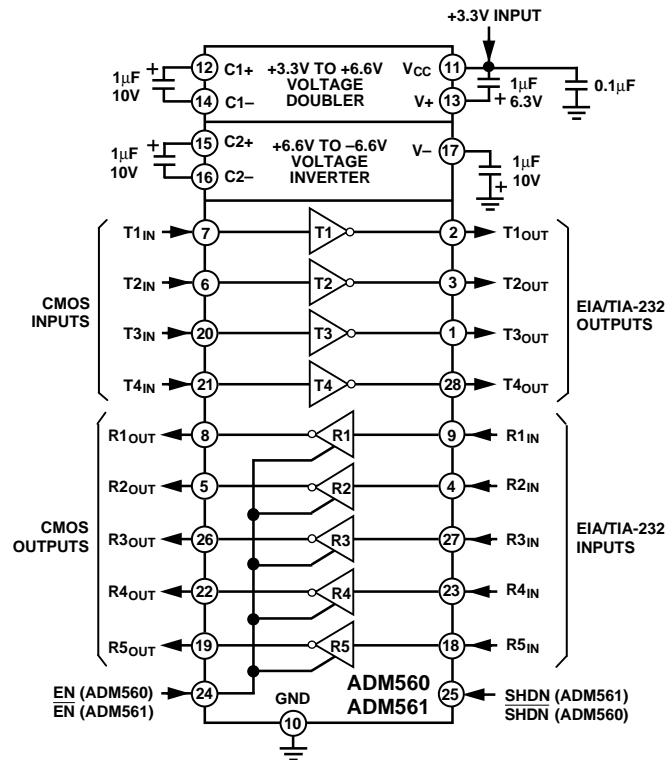

can withstand up to ± 25 V levels. The transmitter inputs can be driven from either 3 V or 5 V logic levels. This allows operation in mixed 3 V/5 V power supply systems.

The ADM560/ADM561 is packaged in a 28-pin SO and a 28-pin SSOP package.

ORDERING GUIDE

Model	Temperature Range	Package Option
ADM560JR	0°C to +70°C	R-28
ADM560JRS	0°C to +70°C	RS-28
ADM561JR	0°C to +70°C	R-28
ADM561JRS	0°C to +70°C	RS-28

REV. 0

Information furnished by Analog Devices is believed to be accurate and reliable. However, no responsibility is assumed by Analog Devices for its use, nor for any infringements of patents or other rights of third parties which may result from its use. No license is granted by implication or otherwise under any patent or patent rights of Analog Devices.

One Technology Way, P.O. Box 9106, Norwood, MA 02062-9106, U.S.A.
 Tel: 617/329-4700 Fax: 617/326-8703

ADM560/ADM561—SPECIFICATIONS ($V_{CC} = +3.3\text{ V} \pm 10\%$, C1–C4 = 1 μF . All specifications T_{MIN} to T_{MAX} unless otherwise noted.)

Parameter	Min	Typ	Max	Units	Test Conditions/Comments
Output Voltage Swing	± 5.0	± 5.5		Volts	$V_{CC} = 3.3\text{ V}$, Three Transmitter Outputs Loaded with 3 k Ω to Ground
	± 4	± 4.5		Volts	$V_{CC} = 3.0\text{ V}$, All Transmitter Outputs Loaded into 3 k Ω to Ground
V_{CC} Power Supply Current		1.3	2	mA	No Load, $T_{IN} = V_{CC}$
		2.2	3.0	mA	No Load, $T_{IN} = \text{GND}$
Shutdown Supply Current		0.2	5	μA	$\overline{\text{SHDN}} = \text{GND}$ (ADM560); SHDN = V_{CC} (ADM561), $T_{IN} = V_{CC}$
Input Logic Threshold Low, V_{INL}			0.4	V	$T_{IN}, \text{EN}, \overline{\text{EN}}, \text{SHDN}, \overline{\text{SHDN}}$
Input Logic Threshold High, V_{INH}	2.4			V	$T_{IN}, \text{EN}, \overline{\text{EN}}, \text{SHDN}, \overline{\text{SHDN}}$
Logic Pullup Current		3	20	μA	$T_{IN} = \text{GND}$
EIA-232 Input Voltage Range	-25		+25	V	
EIA-232 Input Threshold Low	0.4	0.8		V	
EIA-232 Input Threshold High		1.1	2.4	V	
EIA-232 Input Hysteresis		0.3		V	
EIA-232 Input Resistance	3	5	7	k Ω	
CMOS Output Voltage Low, V_{OL}			0.4	V	$I_{OUT} = 1.6\text{ mA}$
CMOS Output Voltage High, V_{OH}	2.8			V	$I_{OUT} = -40\ \mu\text{A}$
CMOS Output Leakage Current		0.05	± 5	μA	$\overline{\text{EN}} = V_{CC}, \text{EN} = \text{GND}, 0\text{ V} \leq R_{OUT} \leq V_{CC}$
Output Enable Time		200		ns	
Output Disable Time		300		ns	
Receiver Propagation Delay					
TPHL		0.4	1	μs	
TPLH		1.3	2	μs	
Instantaneous Slew Rate			30	V/ μs	$C_L = 50\text{ pF}, R_L = 3\text{ k}\Omega\text{--}7\text{ k}\Omega$
Transition Region Slew Rate		5.0		V/ μs	$R_L = 3\text{ k}\Omega, C_L = 2500\text{ pF}$ Measured from +3 V to -3 V or -3 V to +3 V
Transmitter Output Resistance	300			Ω	$V_{CC} = V+ = V- = 0\text{ V}, V_{OUT} = \pm 2\text{ V}$
RS-232 Output Short Circuit Current		± 10		mA	

Specifications subject to change without notice.

ABSOLUTE MAXIMUM RATINGS*

($T_A = +25^\circ\text{C}$ unless otherwise noted)

V_{CC}	-0.3 V to +6 V
V+	($V_{CC} - 0.3\text{ V}$) to +14 V
V-	+0.3 V to -14 V
Input Voltages	
T_{IN}	-0.3 V to ($V+, +0.3\text{ V}$)
R_{IN}	$\pm 25\text{ V}$
Output Voltages	
T_{OUT}	($V+, +0.3\text{ V}$) to ($V-, -0.3\text{ V}$)
R_{OUT}	-0.3 V to ($V_{CC} + 0.3\text{ V}$)
Short Circuit Duration	
T_{OUT}	Continuous

Power Dissipation

SSOP	900 mW
SOIC	900 mW
Operating Temperature Range	
Commercial (J Version)	0°C to +70°C
Storage Temperature Range	-65°C to +150°C
Lead Temperature (Soldering, 10 sec)	+300°C
ESD Rating	>2000 V

*This is a stress rating only and functional operation of the device at these or any other conditions above those indicated in the operation sections of this specification is not implied. Exposure to absolute maximum rating conditions for extended periods of time may affect reliability.

ADM560/ADM561

PIN FUNCTION DESCRIPTION

Mnemonic	Function
V _{CC}	Power Supply Input 3.3 V ± 10%.
V+	Internally Generated Positive Supply (+6.6 V Nominal).
V-	Internally Generated Negative Supply (-6.6 V Nominal).
GND	Ground Pin. Must Be Connected to 0 V.
C1+, C1-	External Capacitor 1 Is Connected Between These Pins.
C2+, C2-	External Capacitor 2 Is Connected Between These Pins.
T _{IN}	Transmitter (Driver) Inputs. These Inputs Accept 3 V or 5 V Logic Levels. An Internal 400 kΩ Pull-Up Resistor to V _{CC} Is Connected On Each Input.
T _{OUT}	Transmitter (Driver) Outputs (Typically ±6 V).
R _{IN}	Receiver Inputs. These inputs accept RS-232 Signal Levels. An Internal 5 kΩ Pull-Down Resistor to GND Is Connected on Each of These Inputs.
R _{OUT}	Receiver Outputs. These are 3 V Logic Levels.
EN/ $\overline{\text{EN}}$	Receiver Enable (Active High on ADM560); Active Low on ADM561) Refer to Table I.
$\overline{\text{SHDN}}$ /SHDN	Shutdown Control (Active Low on ADM560); (Active High on ADM561) Refer to Table I.

PIN CONFIGURATIONS

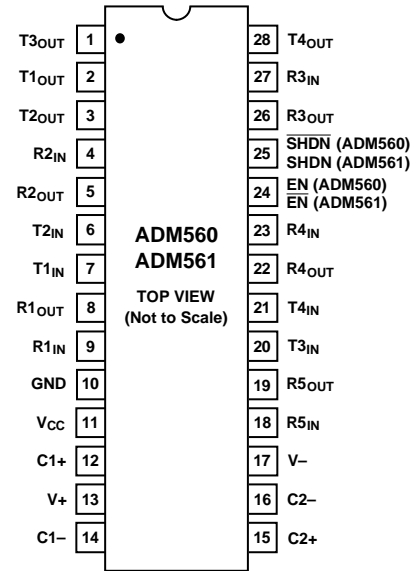

Table I.

	ADM560	ADM561
Normal Operation	$\overline{\text{SHDN}} = 1$ EN = 1 Receivers Active EN = 0 Receivers Inactive	SHDN = 0 $\overline{\text{EN}} = 0$; Receivers Active EN = 1; Receivers Inactive
Shutdown Mode	$\overline{\text{SHDN}} = 0$ EN = 1 Receivers R1–R3 Inactive EN = 1 Receivers R4 & R5 Active EN = 0 Receivers R1–R5 Inactive	SHDN = 1 $\overline{\text{EN}} = 0$; Receivers Inactive EN = 1; Receivers Inactive

ADM560/ADM561

GENERAL DESCRIPTION

The ADM560/ADM561 are RS-232 transmission line drivers/receivers which operate from a single +3.3 V supply. This is achieved by integrating step up voltage converters and level shifting transmitters and receivers onto the same chip. CMOS technology is used to keep the power dissipation to an absolute minimum. The ADM560/ADM561 is a modification, enhancement and improvement to the AD230-AD241 family and derivatives thereof. It is essentially plug-in compatible and does not have materially different applications.

The ADM560/ADM561 contains an internal voltage doubler and a voltage inverter which generates ± 6.6 V from the +3.3 V input. Four external 1 μ F capacitors are required for the internal voltage converter.

CIRCUIT DESCRIPTION

The internal circuitry consists of three main sections. These are:

1. A charge pump voltage converter
2. 3 V Logic to EIA-232 transmitters
3. EIA-232 to 3 V Logic receivers.

Charge Pump DC-DC Voltage Converter

The Charge Pump Voltage converter consists of an oscillator and a switching matrix. The converter generates a ± 6.6 V supply from the input +3.3 V level. This is done in two stages using a switched capacitor technique as illustrated below. First, the 3.3 V input supply is doubled to 6.6 V using capacitor C1 as the charge storage element. The 6.6 V level is then inverted to generate -6.6 V using C2 as the storage element.

Capacitors C3 and C4 are used to reduce the output ripple. Their values are not critical and can be reduced if higher levels of ripple are acceptable. The charge pump capacitors C1 and C2 may also be reduced at the expense of higher output impedance on the V+ and V- supplies.

The V+ and V- supplies may also be used to power external circuitry if the current requirements are small.

Transmitter (Driver) Section

The Drivers convert 3 V or 5 V logic input levels into EIA-232 output levels. With $V_{CC} = +3.3$ V and driving an EIA-232 load, the output voltage swing is typically ± 5.5 V.

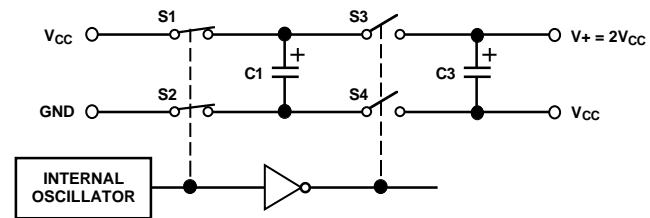

Figure 1. Charge Pump Voltage Doubler

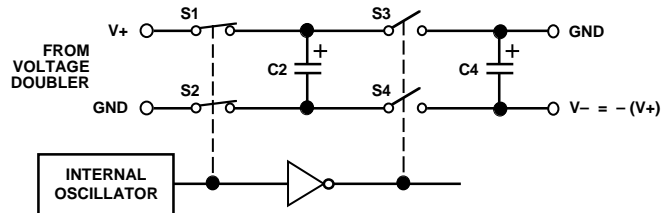

Figure 2. Charge Pump Voltage Inverter

Unused inputs may be left unconnected, as an internal 400 k Ω pull-up resistor pulls them high forcing the outputs into a low state. The input pull-up resistors typically source 8 μ A when grounded so unused inputs should either be connected to V_{CC} or left unconnected in order to minimize power consumption.

Receiver Section

The receivers are inverting level shifters which accept EIA-232 input levels and translate them into 3 V logic output levels. The inputs have internal 5 k Ω pull-down resistors to ground and are also protected against overvoltages of up to ± 25 V. The guaranteed switching thresholds are 0.4 V minimum and 2.4 V maximum. Unconnected inputs are pulled to 0 V by the internal 5 k Ω pull-down resistor. This, therefore, results in a Logic 1 output level for unconnected inputs or for inputs connected to GND.

The receivers have schmitt trigger input with a hysteresis level of 0.3 V. This ensures error-free reception for both noisy inputs and for inputs with slow transition times.

ENABLE AND SHUTDOWN

Table I shows the truth table for the enable and shutdown control signals. When disabled, all receivers are placed in a high impedance state. In shutdown, all transmitters are disabled and all receivers on the ADM561 are disabled. On the ADM560, receivers R4 and R5 remain enabled in shutdown.

Typical Performance Curves

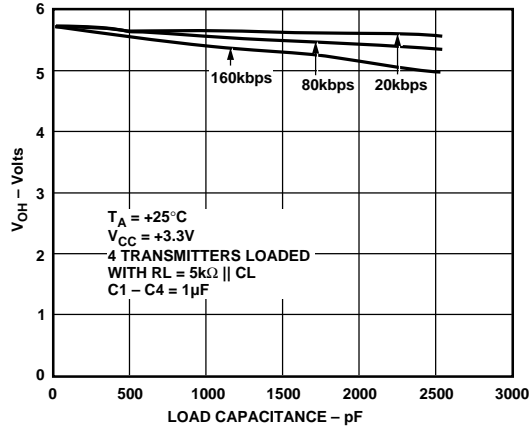

Figure 3. Transmitter Output Voltage High vs. Load Capacitance

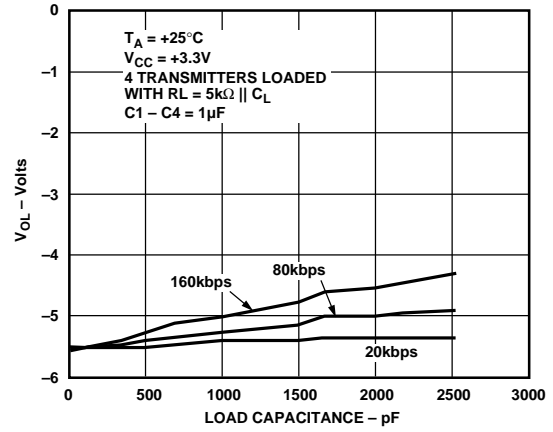

Figure 6. Transmitter Output Voltage Low vs. Load Capacitance

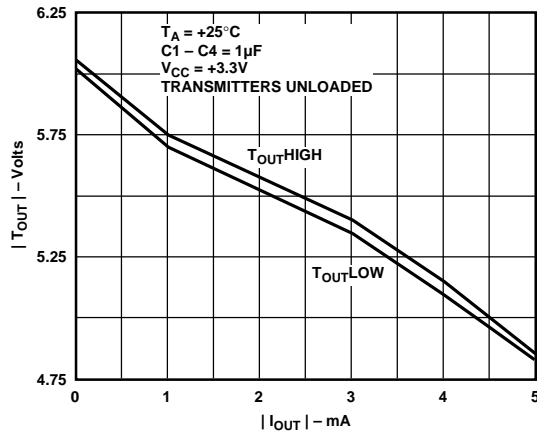

Figure 4. Transmitter Output Voltage vs. Load Current

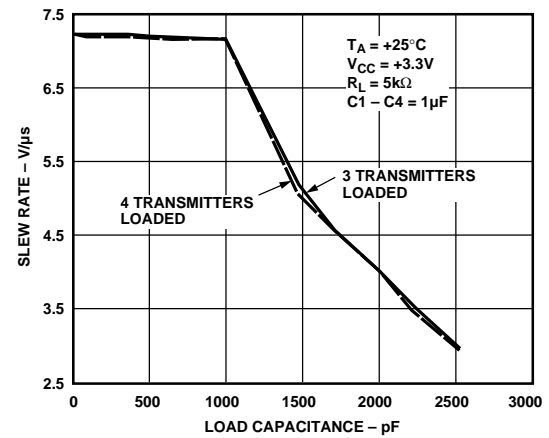

Figure 7. Transmitter Slew Rate vs. Load Capacitance

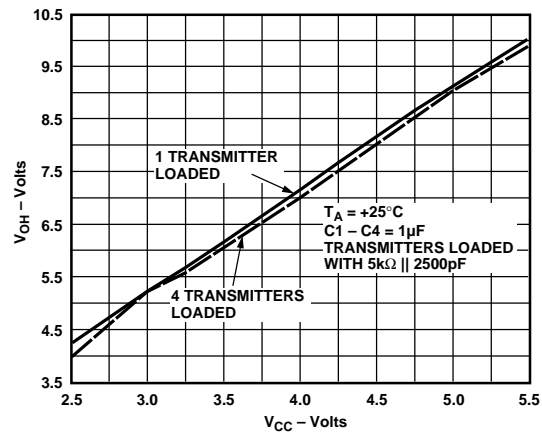

Figure 5. Transmitter Output Voltage High vs. V_{CC}

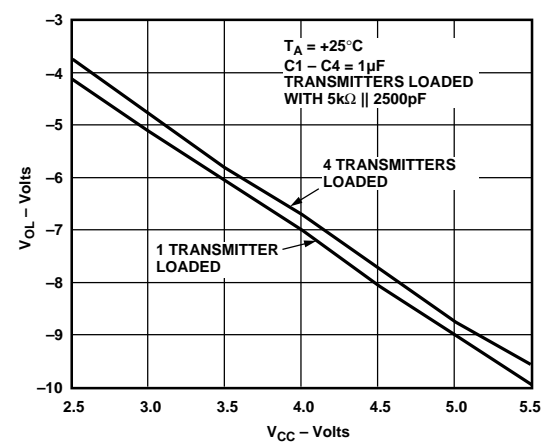

Figure 8. Transmitter Output Voltage Low vs. V_{CC}

ADM560/ADM561

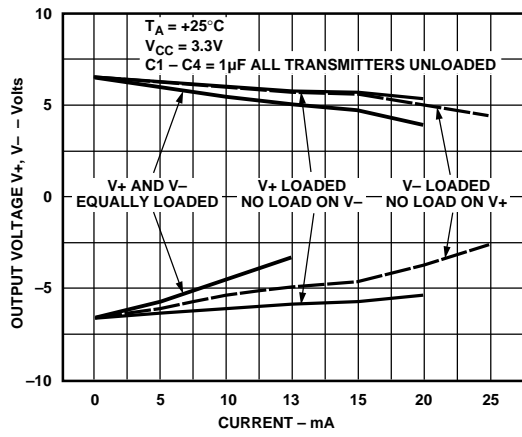
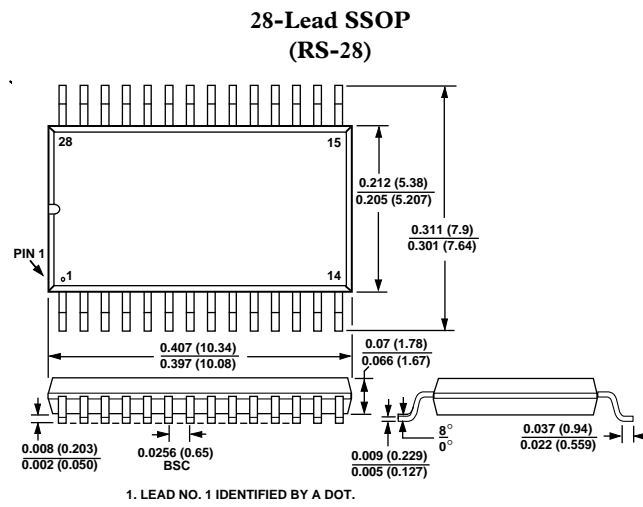
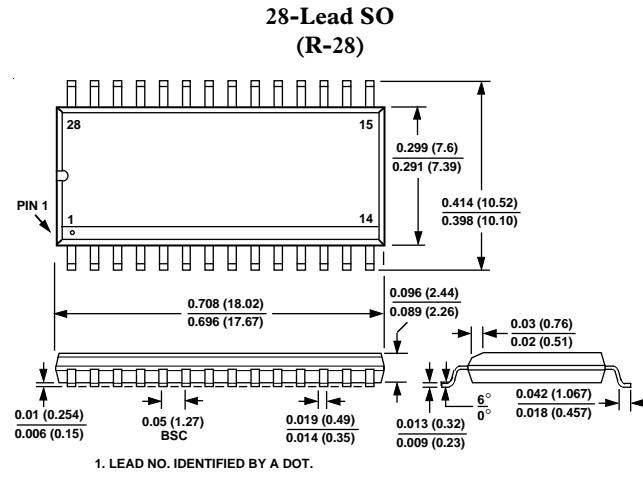

Figure 9. V_+ , V_- vs. Load Current

OUTLINE DIMENSIONS

Dimensions shown in inches and (mm).



C1940-5-7/94

PRINTED IN U.S.A.