

## ADM222/ADM232A/ADM242\*

### FEATURES

- 200 kB/s Transmission Rate
- Small (0.1  $\mu$ F) Charge Pump Capacitors
- Single 5 V Power Supply
- Meets All EIA-232-E and V.28 Specifications
- Two Drivers and Two Receivers
- On-Board DC-DC Converters
- $\pm 9$  V Output Swing with 5 V Supply
- $\pm 30$  V Receiver Input Levels
- Pin Compatible with MAX222/MAX232A/MAX242

### APPLICATIONS

- Computers
- Peripherals
- Modems
- Printers
- Instruments

### GENERAL DESCRIPTION

The ADM222, ADM232A, ADM242 are a family of high-speed RS-232 line drivers/receivers offering transmission rates up to 200 kB/s. Operating from a single 5 V power supply, a highly efficient on-chip charge pump using small (0.1  $\mu$ F) external capacitors allows RS-232 bipolar levels to be developed. Two RS-232 drivers and two RS-232 receivers are provided on each device.

The devices are fabricated on BiCMOS, an advanced mixed technology process that combines low power CMOS with high-speed bipolar circuitry. This allows for transmission rates up to 200 kB/s, yet minimizes the quiescent power supply current to under 5 mA.

The ADM232A is a pin-compatible, high-speed upgrade for the AD232 and for the ADM232L. It is available in 16-lead DIP and in both narrow and wide surface-mount (SOIC) packages.

The ADM222 contains an additional shutdown ( $\overline{\text{SHDN}}$ ) function that may be used to disable the device, thereby reducing the supply current to 0.1  $\mu$ A. During shutdown, all transmit/receive

### FUNCTIONAL BLOCK DIAGRAM

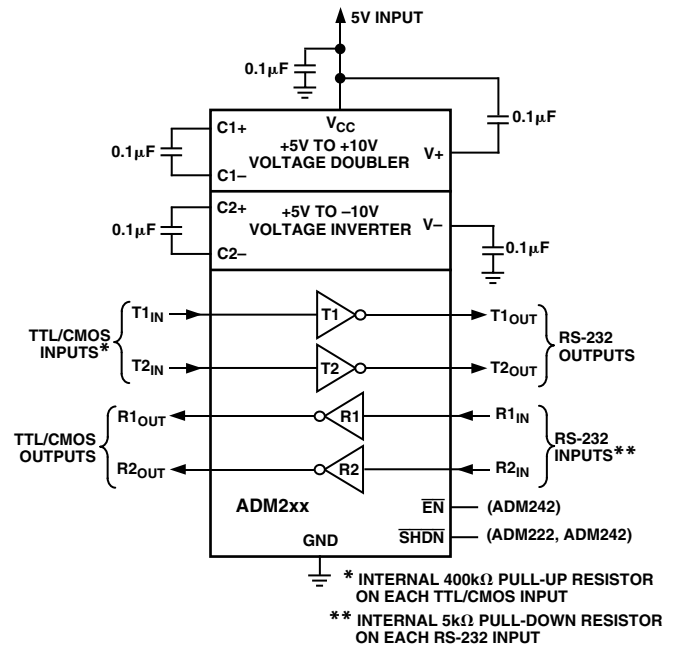

functions are disabled. The ADM222 is available in 18-lead DIP and in a wide surface-mount (SOIC) package.

The ADM242 combines both shutdown ( $\overline{\text{SHDN}}$ ) and enable ( $\overline{\text{EN}}$ ) functions. The shutdown function reduces the supply current to 0.1 mA. During shutdown, the transmitters are disabled but the receivers continue to operate normally. The enable function allows the receiver outputs to be disabled thereby facilitating sharing a common bus. The ADM242 is available in 18-lead DIP and in a wide surface-mount (SOIC) package.

\*Protected by U.S. Patent No. 5,237,209.

### REV. A

Information furnished by Analog Devices is believed to be accurate and reliable. However, no responsibility is assumed by Analog Devices for its use, nor for any infringements of patents or other rights of third parties which may result from its use. No license is granted by implication or otherwise under any patent or patent rights of Analog Devices.

# ADM222/ADM232A/ADM242—SPECIFICATIONS (V<sub>CC</sub> = 5 V ± 10%. C1–C4 = 0.1 μF; all specifications T<sub>MIN</sub> to T<sub>MAX</sub> unless otherwise noted.)

Parameter	Min	Typ	Max	Unit	Test Conditions/Comments
<b>RS-232 TRANSMITTERS</b>					
Output Voltage Swing	±5	±9		V	All Transmitter Outputs Loaded with 3 kΩ to Ground
Input Logic Threshold Low, V <sub>INL</sub>		1.7	0.8	V	T <sub>IN</sub>
Input Logic Threshold High, V <sub>INH</sub>	2.4	1.7		V	T <sub>IN</sub>
Logic Pull-Up Current		12	40	μA	T <sub>IN</sub> = 0 V
Data Rate	200			kB/s	
Output Resistance	300			Ω	V <sub>CC</sub> = V+ = V- = 0 V, V <sub>OUT</sub> = ±2 V
Output Short Circuit Current (Instantaneous)		±10		mA	
<b>RS-232 RECEIVERS</b>					
RS-232 Input Voltage Range	-30		+30	V	
RS-232 Input Threshold Low	0.8	1.2		V	
RS-232 Input Threshold High		1.6	2.4	V	
RS-232 Input Hysteresis	0.2	0.4	1.0	V	V <sub>CC</sub> = 5 V
RS-232 Input Resistance	3	5	7	kΩ	T <sub>A</sub> = 0°C to 85°C
TTL/CMOS Output Voltage Low, V <sub>OL</sub>		0.05	0.4	V	I <sub>OUT</sub> = 3.2 mA
TTL/CMOS Output Voltage High, V <sub>OH</sub>	3.5			V	I <sub>OUT</sub> = -1.0 mA
TTL/CMOS Output Short-Circuit Current	-2	-85		mA	Source Current (V <sub>OUT</sub> = GND)*
TTL/CMOS Output Short-Circuit Current	10	35		mA	Sink Current (V <sub>OUT</sub> = V <sub>CC</sub> )*
TTL/CMOS Output Leakage Current		±0.05	±10	μA	$\overline{\text{SHDN}} = \text{GND}/\overline{\text{EN}} = \text{V}_{\text{CC}}$ 0 V ≤ V <sub>OUT</sub> ≤ V <sub>CC</sub>
$\overline{\text{EN}}$ Input Threshold Low, V <sub>INL</sub>		1.4	0.8	V	
$\overline{\text{EN}}$ Input Threshold High, V <sub>INH</sub>	2.0	1.4		V	
<b>POWER SUPPLY</b>					
Power Supply Current		4	8	mA	No Load
		13		mA	3 kΩ Load on Both Outputs
Shutdown Power Supply Current		0.1	10	μA	
$\overline{\text{SHDN}}$ Input Leakage Current			±1	μA	
$\overline{\text{SHDN}}$ Input Threshold Low, V <sub>INL</sub>		1.4	0.8	V	
$\overline{\text{SHDN}}$ Input Threshold High, V <sub>INH</sub>	2.0	1.4		V	
<b>AC CHARACTERISTICS</b>					
Transition Region Slew Rate	3	8	30	V/μs	C <sub>L</sub> = 50 pF to 1000 pF, R <sub>L</sub> = 3 kΩ to 7 kΩ Measured from +3 V to -3 V or -3 V to +3 V
Transmitter Propagation Delay TTL to RS-232		0.85	3.5	μs	t <sub>PHLT</sub>
		1.0	3.5	μs	t <sub>PLHT</sub>
Receiver Propagation Delay RS-232 to TTL		0.1	0.5	μs	t <sub>PHLR</sub>
		0.3	0.5	μs	t <sub>PLHR</sub>
Receiver Output Enable Time		125	500	ns	t <sub>ER</sub>
Receiver Output Disable Time		160	500	ns	t <sub>DR</sub>
Transmitter Output Enable Time		250		μs	$\overline{\text{SHDN}}$ Goes High
Transmitter Output Disable Time		3.5		μs	$\overline{\text{SHDN}}$ Goes Low
Transmitter + to - Propagation Delay Difference		150		ns	
Receiver + to - Propagation Delay Difference		200		ns	

\*Guaranteed by design, not production tested.

Specifications subject to change without notice.

# ADM222/ADM232A/ADM242

## ABSOLUTE MAXIMUM RATINGS\*

( $T_A = 25^\circ\text{C}$  unless otherwise noted)

$V_{CC}$ .....	6 V
$V_+$ .....	( $V_{CC} - 0.3$ V) to +13 V
$V_-$ .....	+0.3 V to -13 V
<b>Input Voltages</b>	
$T_{IN}$ .....	-0.3 V to ( $V_{CC} + 0.3$ V)
$R_{IN}$ .....	$\pm 30$ V
<b>Output Voltages</b>	
$T_{OUT}$ .....	( $V_+$ , +0.3 V) to ( $V_-$ , -0.3 V)
$R_{OUT}$ .....	-0.3 V to ( $V_{CC} + 0.3$ V)
<b>Short Circuit Duration</b>	
$T_{OUT}$ .....	Continuous
<b>Power Dissipation N-16</b> .....	
	400 mW
	(Derate 7.5 mW/ $^\circ\text{C}$ above $70^\circ\text{C}$ )
$\theta_{JA}$ , Thermal Impedance .....	80 $^\circ\text{C}/\text{W}$
<b>Power Dissipation R-16N</b> .....	
	400 mW
	(Derate 7 mW/ $^\circ\text{C}$ above $70^\circ\text{C}$ )
$\theta_{JA}$ , Thermal Impedance .....	80 $^\circ\text{C}/\text{W}$
<b>Power Dissipation R-16W</b> .....	
	400 mW
	(Derate 7 mW/ $^\circ\text{C}$ above $70^\circ\text{C}$ )
$\theta_{JA}$ , Thermal Impedance .....	80 $^\circ\text{C}/\text{W}$
<b>Power Dissipation N-18</b> .....	
	400 mW
	(Derate 7 mW/ $^\circ\text{C}$ above $70^\circ\text{C}$ )
$\theta_{JA}$ , Thermal Impedance .....	80 $^\circ\text{C}/\text{W}$

Power Dissipation R-18W .....	400 mW
	(Derate 7 mW/ $^\circ\text{C}$ above $70^\circ\text{C}$ )
$\theta_{JA}$ , Thermal Impedance .....	80 $^\circ\text{C}/\text{W}$
<b>Operating Temperature Range</b>	
Industrial (A Version) .....	-40 $^\circ\text{C}$ to +85 $^\circ\text{C}$
Storage Temperature Range .....	-65 $^\circ\text{C}$ to +150 $^\circ\text{C}$
Lead Temperature (Soldering, 10 sec) .....	300 $^\circ\text{C}$
Vapor Phase (60 sec) .....	215 $^\circ\text{C}$
Infrared (15 sec) .....	220 $^\circ\text{C}$

\*This is a stress rating only and functional operation of the device at these or any other conditions above those indicated in the operation sections of this specification is not implied. Exposure to absolute maximum rating conditions for extended periods of time may affect reliability.

## ORDERING GUIDE

Model	Temperature Range	Package Description	Package Option
ADM222AN	-40 $^\circ\text{C}$ to +85 $^\circ\text{C}$	Plastic DIP	N-18
ADM222AR	-40 $^\circ\text{C}$ to +85 $^\circ\text{C}$	Wide SOIC	R-18W
ADM232AAN	-40 $^\circ\text{C}$ to +85 $^\circ\text{C}$	Plastic DIP	N-16
ADM232AARN	-40 $^\circ\text{C}$ to +85 $^\circ\text{C}$	Narrow SOIC	R-16N
ADM232AARW	-40 $^\circ\text{C}$ to +85 $^\circ\text{C}$	Wide SOIC	R-16W
ADM242AN	-40 $^\circ\text{C}$ to +85 $^\circ\text{C}$	Plastic DIP	N-18
ADM242AR	-40 $^\circ\text{C}$ to +85 $^\circ\text{C}$	Wide SOIC	R-18W

## Test Circuits

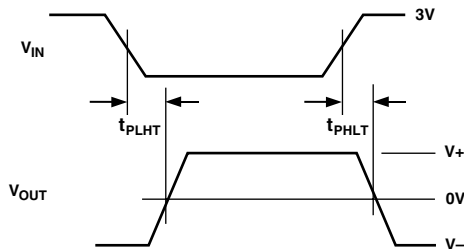

Figure 1. Transmitter Propagation Delay Timing

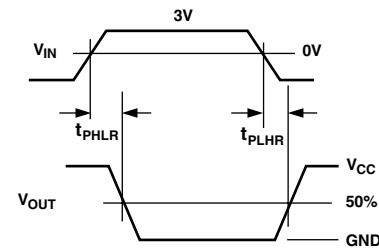

Figure 3. Receiver Propagation Delay Timing

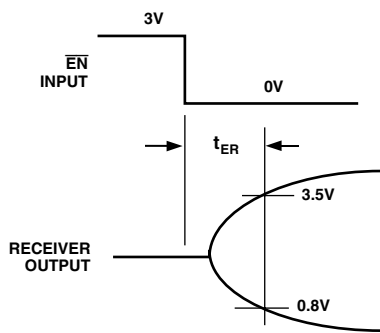

Figure 2. Receiver Enable Timing

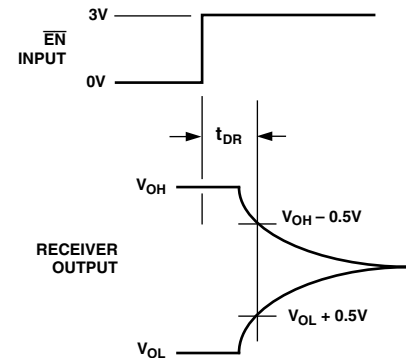

Figure 4. Receiver Disable Timing

# ADM222/ADM232A/ADM242

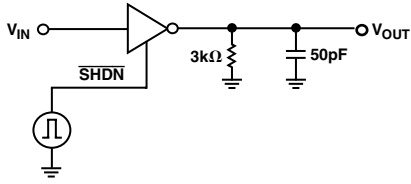

Figure 5. Shutdown Test Circuit

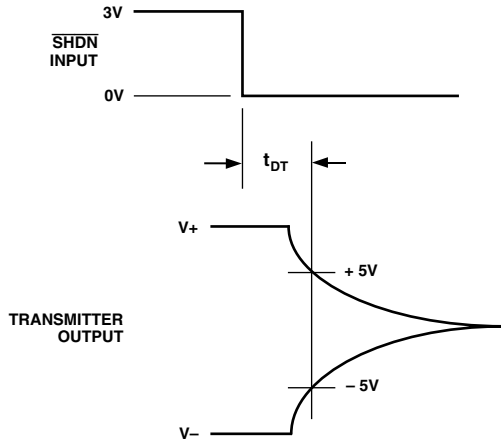

Figure 6. Transmitter Shutdown Disable Timing

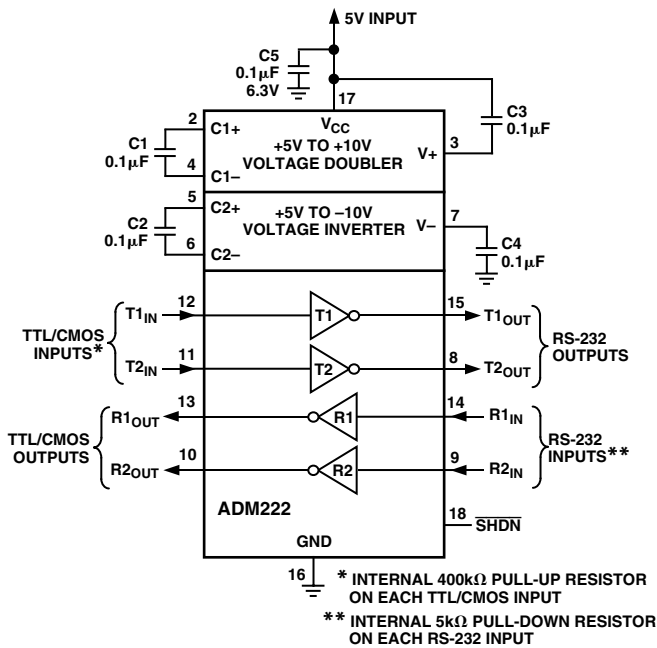

Figure 7. ADM222 Typical Operating Circuit

## PIN FUNCTION DESCRIPTION

Mnemonic	Function
V <sub>CC</sub>	Power Supply Input, 5 V ± 10%.
V+	Internally generated positive supply (+10 V nominal).
V-	Internally generated negative supply (-10 V nominal).
GND	Ground Pin. Must be connected to 0 V.
C1+	External capacitor 1, (+ terminal) is connected to this pin.
C1-	External capacitor 1, (- terminal) is connected to this pin.
C2+	External capacitor 2, (+ terminal) is connected to this pin.
C2-	External capacitor 2, (- terminal) is connected to this pin.
T <sub>IN</sub>	Transmitter (Driver) Inputs. These inputs accept TTL/CMOS levels. An internal 400 kΩ pull-up resistor to V <sub>CC</sub> is connected on each input.
T <sub>OUT</sub>	Transmitter (Driver) Outputs. These are RS-232 levels (typically ±9 V).
R <sub>IN</sub>	Receiver Inputs. These inputs accept RS-232 signal levels. An internal 5 kΩ pull-down resistor to GND is connected on each of these inputs.
R <sub>OUT</sub>	Receiver Outputs. These are TTL/CMOS levels.
NC	No Connect. No connections are required to this pin.
$\overline{\text{EN}}$	(ADM242 Only) Active Low Digital Input. May be used to enable or disable (three-state) both receiver outputs.
$\overline{\text{SHDN}}$	(ADM222 and ADM242) Active Low Digital Input. May be used to disable the device so that the power consumption is minimized. On the ADM222 all drivers and receivers are disabled. On the ADM242 the drivers are disabled but the receivers remain enabled.

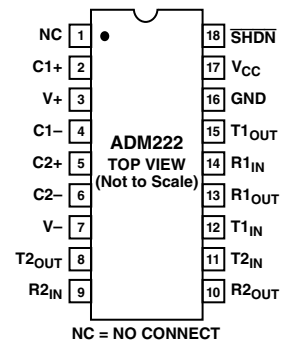

Figure 8. ADM222 DIP and SOIC Pin Configurations

# ADM222/ADM232A/ADM242

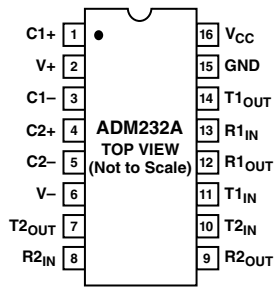

Figure 9. ADM232A DIP/SOIC Pin Configuration

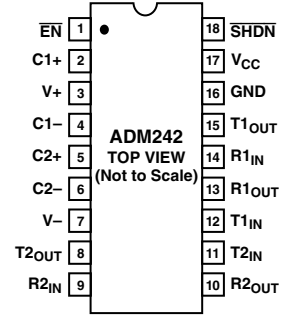

Figure 11. ADM242 DIP/SOIC Pin Configuration

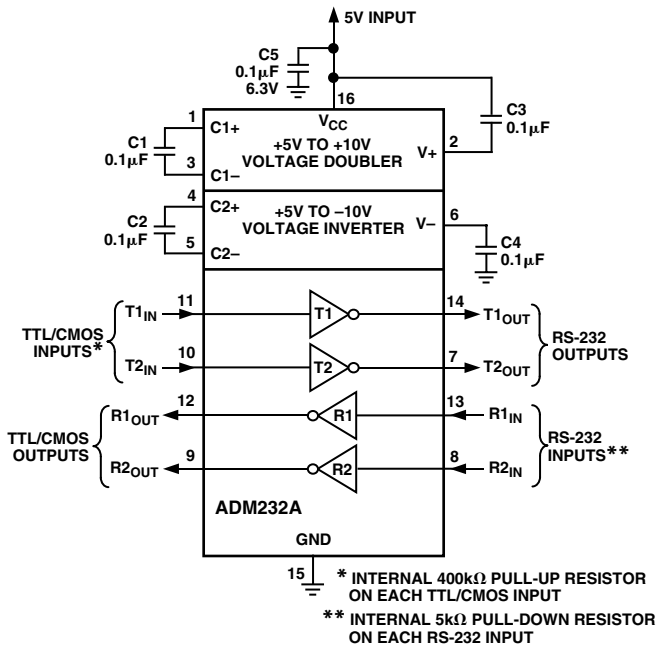

Figure 10. ADM232A Typical Operating Circuit

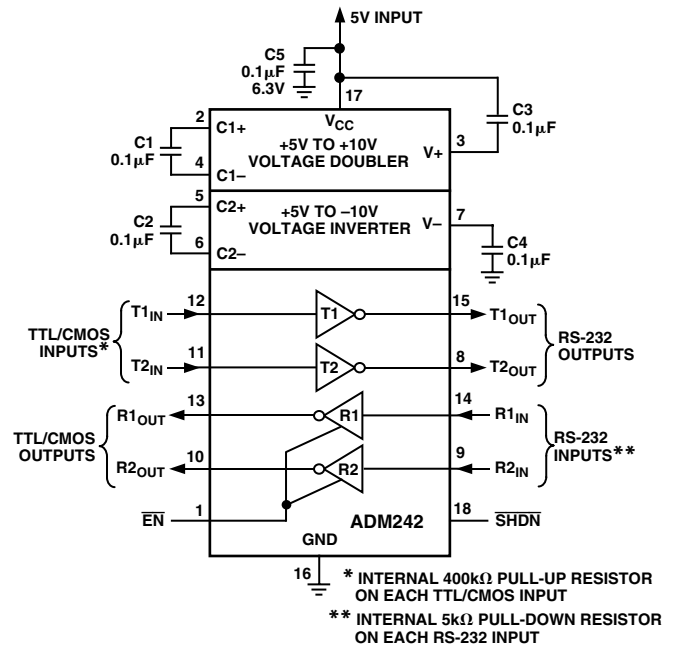
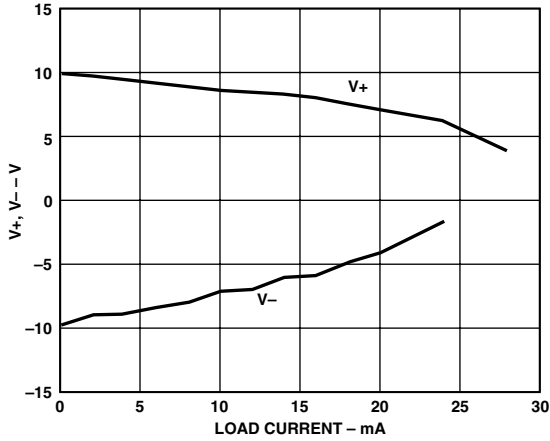
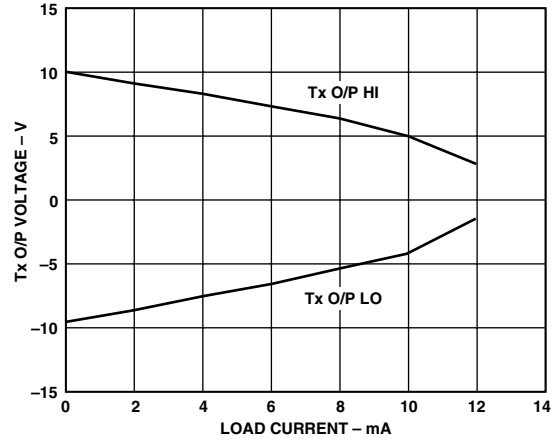

Figure 12. ADM242 Typical Operating Circuit

# ADM222/ADM232A/ADM242 – Typical Performance Characteristics



TPC 1. Charge Pump V+, V- vs. Current



TPC 4. Transmitter Output Voltage vs. Current

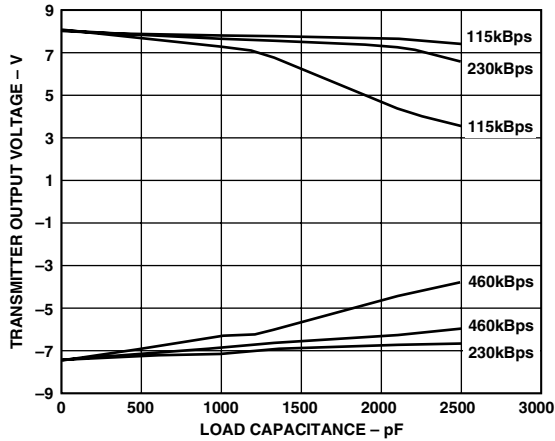

TPC 2. Transmitter Baud Rate vs. Load Capacitance

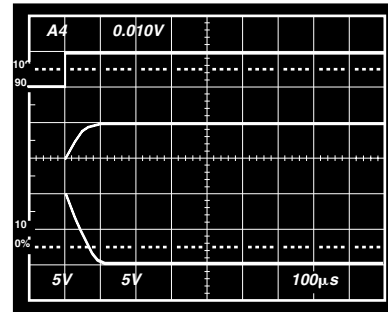

TPC 5. Charge Pump V+, V- Exiting Shutdown

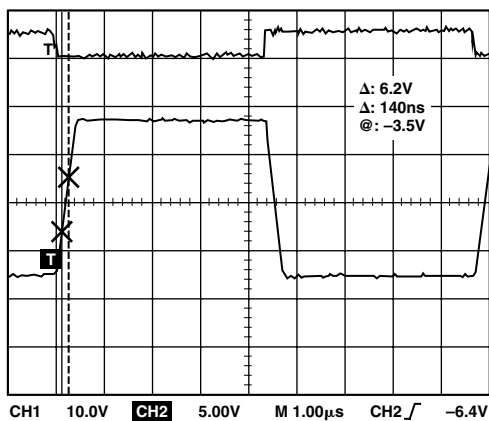

TPC 3. Transmitter Unloaded Slew Rate

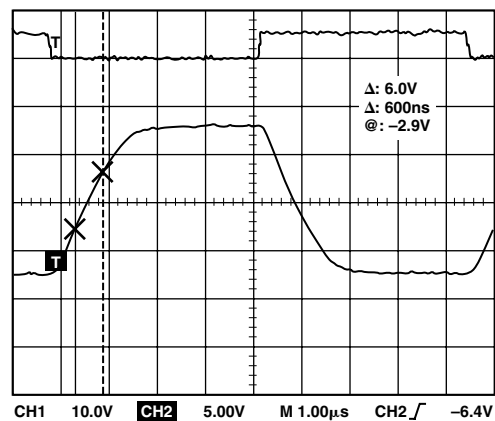

TPC 6. Transmitter Fully Loaded Slew Rate

## GENERAL INFORMATION

The ADM222/ADM232A/ADM242 are high-speed RS-232 drivers/receivers requiring a single digital 5 V supply. The RS-232 standard requires transmitters that will deliver  $\pm 5$  V minimum on the transmission channel and receivers that can accept signal levels down to  $\pm 3$  V. The parts achieve this by integrating step-up voltage converters and level-shifting transmitters and receivers onto the same chip. CMOS technology is used to keep the power dissipation to an absolute minimum. All devices contain an internal charge pump voltage doubler and a voltage inverter that generates  $\pm 10$  V from the 5 V input. Four external 0.1  $\mu$ F capacitors are required for the internal charge pump voltage converter.

The ADM222/ADM232A/ADM242 is a modification, enhancement and improvement to the AD230-AD241 family and derivatives thereof. It is essentially plug-in-compatible and does not have materially different applications.

## CIRCUIT DESCRIPTION

The internal circuitry consists of four main sections. These are:

- Charge Pump Voltage Converter
- TTL/CMOS to RS-232 Transmitters
- RS-232 to TTL/CMOS Receivers
- Enable and Shutdown Functions.

### Charge Pump DC-DC Voltage Converter

The Charge Pump Voltage converter consists of an oscillator and a switching matrix. The converter generates a  $\pm 10$  V supply from the input 5 V level. This is done in two stages using a switched capacitor technique. The 5 V input supply is doubled to 10 V using capacitor C1 as the charge storage element. The  $-10$  V level is also generated from the input 5 V supply using C1 and C2 as the storage elements.

Capacitors C3 and C4 are used to reduce the output ripple. Their values are not critical and can be reduced if higher levels of ripple are acceptable. The charge pump capacitors C1 and C2 may also be reduced at the expense of higher output impedance on the V+ and V- supplies.

The V+ and V- supplies may also be used to power external circuitry if the current requirements are small. Please refer to the typical performance characteristics which shows the V+, V- output voltage vs. current.

In the shutdown mode the charge pump is disabled and V+ decays to  $V_{CC}$  while V- decays to 0 V.

### Transmitter (Driver) Section

The Drivers convert TTL/CMOS input levels into RS-232 output levels. With  $V_{CC} = 5$  V and driving a typical RS-232 load, the output voltage swing is  $\pm 9$  V. Even under worst-case conditions the drivers are guaranteed to meet the  $\pm 5$  V RS-232 minimum requirement.

The input threshold levels are both TTL- and CMOS-compatible with the switching threshold set at  $V_{CC}/4$ . With a nominal  $V_{CC} = 5$  V, the switching threshold is 1.25 V typical. Unused inputs may be left unconnected, as an internal 400 k $\Omega$  pull-up resistor pulls them high forcing the outputs into a low state.

As required by the RS-232 standard, the slew rate is limited to less than 30 V/ $\mu$ s without the need for an external slew limiting capacitor, and the output impedance in the power-off state is greater than 300  $\Omega$ .

### Receiver Section

The receivers are inverting level-shifters that accept RS-232 input levels ( $\pm 3$  V to  $\pm 15$  V) and translate them into 5 V TTL/CMOS levels. The inputs have internal 5 k $\Omega$  pull-down resistors to ground and are also protected against overvoltages of up to  $\pm 30$  V. The guaranteed switching thresholds are 0.8 V minimum and 2.4 V maximum, which are well within the  $\pm 3$  V RS-232 requirement. The low level threshold is deliberately positive as it ensures that an unconnected input will be interpreted as a low level.

The receivers have Schmitt trigger input with a hysteresis level of 0.5 V. This ensures error-free reception for both noisy inputs and for inputs with slow transition times

### Enable and Shutdown Functions

On the ADM222, both receivers are fully disabled during shutdown.

On the ADM242, both receivers continue to operate normally. This function is useful for monitoring activity so that when it occurs, the device can be taken out of the shutdown mode.

The ADM242 also contains a receiver enable function ( $\overline{EN}$ ) which can be used to fully disable the receivers, independent of SHDN.

## APPLICATIONS INFORMATION

A selection of typical operating circuits is shown in TPCs 1-6 and Figure 13.

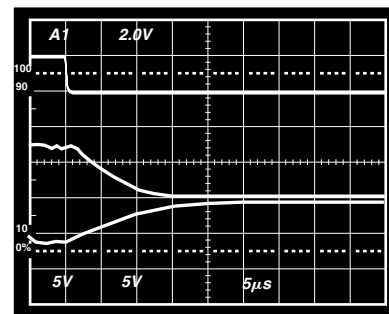

Figure 13. Transmitter Output Disable Timing

# ADM222/ADM232A/ADM242

## OUTLINE DIMENSIONS

Dimensions shown in inches and (mm).

### 16-Lead Plastic DIP (N-16)

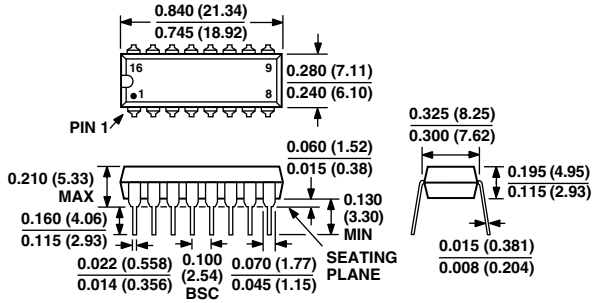

### 16-Lead Narrow SOIC (R-16N)

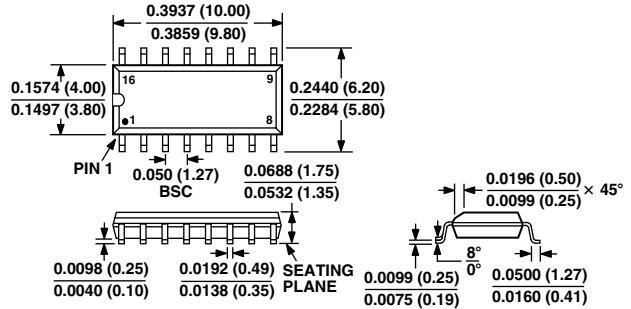

### 16-Lead Wide SOIC (R-16W)

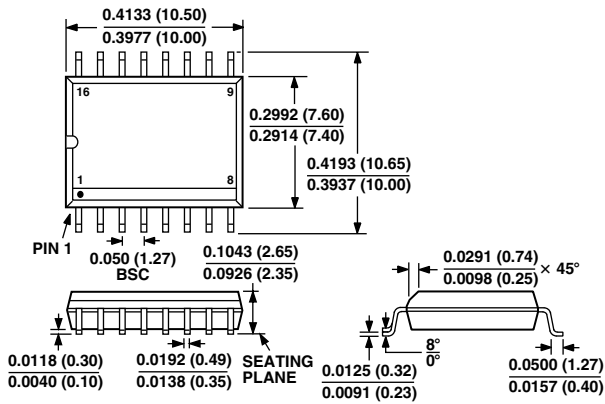

### 18-Lead Wide SOIC (R-18W)

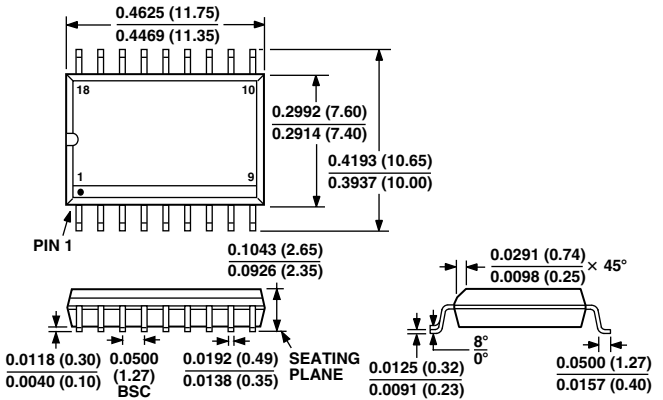

### 18-Lead Plastic DIP (N-18)

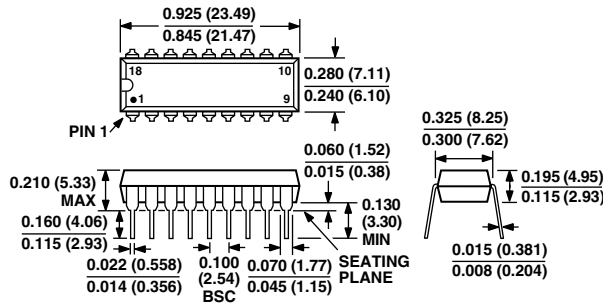

C01213-0-1/01 (rev. A)

PRINTED IN U.S.A.