

FEATURES

High Accuracy

1 Degree rms Quadrature Error @ 1.9 GHz

0.2 dB I/Q Amplitude Balance @ 1.9 GHz

Broad Frequency Range: 0.8 GHz–2.5 GHz

Sideband Suppression: –46 dBc @ 0.8 GHz

Sideband Suppression: –36 dBc @ 1.9 GHz

Modulation Bandwidth: DC–70 MHz

0 dBm Output Compression Level @ 0.8 GHz

Noise Floor: –147 dBm/Hz

Single 2.7 V–5.5 V Supply

Quiescent Operating Current: 45 mA

Standby Current: 1 μ A

16-Lead TSSOP Package

APPLICATIONS

Digital and Spread Spectrum Communication Systems

Cellular/PCS/ISM Transceivers

Wireless LAN/Wireless Local Loop

QPSK/GMSK/QAM Modulators

Single-Sideband (SSB) Modulators

Frequency Synthesizers

Image Reject Mixer

PRODUCT DESCRIPTION

The AD8346 is a silicon RFIC I/Q modulator for use from 0.8 GHz to 2.5 GHz. Its excellent phase accuracy and amplitude balance allow high performance direct modulation to RF.

The differential LO input is applied to a polyphase network phase splitter that provides accurate phase quadrature from 0.8 GHz to 2.5 GHz. Buffer amplifiers are inserted between two sections of the phase splitter to improve the signal-to-noise ratio. The I and Q outputs of the phase splitter drive the LO inputs of two Gilbert-cell mixers. Two differential V-to-I converters connected to the baseband inputs provide the baseband modulation signals for the mixers. The outputs of the two mixers are summed together at an amplifier which is designed to drive a 50 Ω load.

FUNCTIONAL BLOCK DIAGRAM

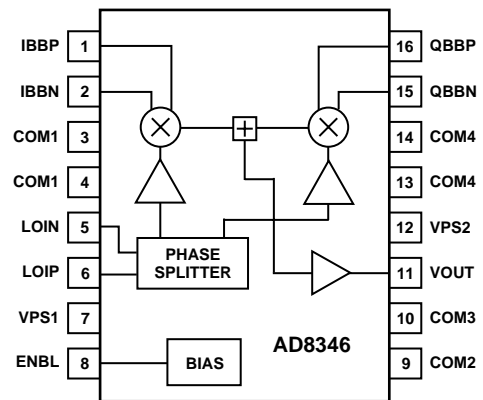

This quadrature modulator can be used as the transmit modulator in digital systems such as PCS, DCS, GSM, CDMA, and ISM transceivers. The baseband quadrature inputs are directly modulated by the LO signal to produce various QPSK and QAM formats at the RF output.

Additionally, this quadrature modulator can be used with direct digital synthesizers in hybrid phase-locked loops to generate signals over a wide frequency range with millihertz resolution.

The AD8346 is supplied in a 16-lead TSSOP package, measuring 6.5 \times 5.1 \times 1.1 mm. It is specified to operate over a –40°C to +85°C temperature range and 2.7 V to 5.5 V supply voltage range. The device is fabricated on Analog Devices' high performance 25 GHz bipolar silicon process.

REV. 0

Information furnished by Analog Devices is believed to be accurate and reliable. However, no responsibility is assumed by Analog Devices for its use, nor for any infringements of patents or other rights of third parties which may result from its use. No license is granted by implication or otherwise under any patent or patent rights of Analog Devices.

AD8346—SPECIFICATIONS ($V_S = 5\text{ V}$; $T_A = +25^\circ\text{C}$, LO frequency = 1900 MHz; LO level = -10 dBm; BB frequency = 100 kHz; BB inputs are dc biased to 1.2 V; BB input level = 1.0 V p-p each pin for 2.0 V p-p differential drive; LO source and RF output load impedances are 50 Ω , dBm units are referenced to 50 Ω unless otherwise noted.)

Parameters	Conditions	Min	Typ	Max	Units
RF OUTPUT					
Operating Frequency		0.8		2.5	GHz
Quadrature Phase Error	(See Figure 29 for Setup)		1		Degree rms
I/Q Amplitude Balance	(See Figure 29 for Setup)		0.2		dB
Output Power	I and Q Channels in Quadrature	-13	-10	-6	dBm
Output VSWR			1.25:1		
Output P1 dB			-3		dBm
Carrier Feedthrough			-42	-35	dBm
Sideband Suppression			-36	-25	dBc
IM3 Suppression			-60		dBc
Equivalent Output IP3			+20		dBm
Output Noise Floor	20 MHz Offset from LO		-147		dBm/Hz
RESPONSE TO CDMA IS95 BASEBAND SIGNALS					
ACPR (Adjacent Channel Power Ratio)	(See Figure 29 for Setup)		-72		dBc
EVM (Error Vector Magnitude)	(See Figure 29 for Setup)		2.5		%
Rho (Waveform Quality Factor)	(See Figure 29 for Setup)		0.9974		
MODULATION INPUT					
Input Resistance			12		k Ω
Modulation Bandwidth	-3 dB		70		MHz
LO INPUT					
LO Drive Level		-12		-6	dBm
Input VSWR			1.9:1		
ENABLE					
ENBL HI Threshold				2.0	V
ENBL LO Threshold		0.5			V
ENBL Turn-On Time	Settle to Within 0.5 dB of Final SSB Output Power		2.5		μs
ENBL Turn-Off Time	Time for Supply Current to Drop Below 2 mA		12		μs
POWER SUPPLIES					
Voltage		2.7		5.5	V
Current Active (ENBL HI)		35	45	55	mA
Current Standby (ENBL LO)			1	20	μA

Specifications subject to change without notice.

ABSOLUTE MAXIMUM RATINGS*

Supply Voltage VPS1, VPS2	5.5 V
Input Power LOIP, LOIN (re. 50 Ω)	+10 dBm
Min Input Voltage IBBP, IBBN, QBBP, QBBN	0 V
Max Input Voltage IBBP, IBBN, QBBP, QBBN	2.5 V
Internal Power Dissipation	500 mW
θ_{JA}	125°C/W
Operating Temperature Range	-40°C to +85°C
Storage Temperature Range	-65°C to +150°C
Lead Temperature Range (Soldering 60 sec)	+300°C

*Stresses above those listed under Absolute Maximum Ratings may cause permanent damage to the device. This is a stress rating only; functional operation of the device at these or any other conditions above those indicated in the operational section of this specification is not implied. Exposure to absolute maximum rating conditions for extended periods may effect device reliability.

CAUTION

ESD (electrostatic discharge) sensitive device. Electrostatic charges as high as 4000 V readily accumulate on the human body and test equipment and can discharge without detection. Although the AD8346 features proprietary ESD protection circuitry, permanent damage may occur on devices subjected to high energy electrostatic discharges. Therefore, proper ESD precautions are recommended to avoid performance degradation or loss of functionality.



ORDERING GUIDE

Model	Temperature Range	Package Description	Package Option
AD8346ARU AD8346ARU-REEL AD8346ARU-REEL7 AD8346-EVAL	-40°C to +85°C	Tube (16-Lead TSSOP) Thin Shrink Small Outline Package 13" Tape and Reel 7" Tape and Reel Evaluation Board	RU-16

PIN CONFIGURATION

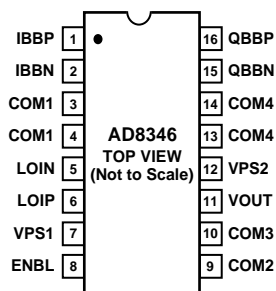

PIN FUNCTION DESCRIPTIONS

Pin	Name	Description	Equivalent Circuit
1	IBBP	I Channel Baseband Positive Input Pin. Input should be dc biased to approximately 1.2 V. Nominal characterized ac swing is 1 V p-p (0.7 V to 1.7 V). This makes the differential input 2 V p-p when IBBN is 180 degrees out of phase from IBBP.	Circuit A
2	IBBN	I Channel Baseband Negative Input Pin. Input should be dc biased to approximately 1.2 V. Nominal characterized ac swing is 1 V p-p (0.7 V to 1.7 V). This makes the differential input 2 V p-p when IBBN is 180 degrees out of phase from IBBP.	Circuit A
3	COM1	Ground pin for the LO phase splitter and LO buffers.	
4	COM1	Ground pin for the LO phase splitter and LO buffers.	
5	LOIN	LO Negative Input Pin. Internal dc bias (approximately VPS1–800 mV) is supplied. This pin must be ac coupled.	Circuit B
6	LOIP	LO Positive Input Pin. Internal dc bias (approximately VPS1–800 mV) is supplied. This pin must be ac coupled.	Circuit B
7	VPS1	Power supply pin for the bias cell and LO buffers. This pin should be decoupled using local 100 pF and 0.01 μ F capacitors.	
8	ENBL	Enable Pin. A high level enables the device; a low level puts the device in sleep mode.	Circuit C
9	COM2	Ground pin for the input stage of output amplifier.	
10	COM3	Ground pin for the output stage of output amplifier.	
11	VOUT	50 Ω DC Coupled RF Output. User must provide ac coupling on this pin.	Circuit D
12	VPS2	Power supply pin for Baseband input voltage to current converters and mixer core. This pin should be decoupled using local 100 pF and 0.01 μ F capacitors.	
13	COM4	Ground pin for Baseband input voltage to current converters and mixer core.	
14	COM4	Ground pin for Baseband input voltage to current converters and mixer core.	
15	QBBN	Q Channel Baseband Negative Input. Input should be dc biased to approximately 1.2 V. Nominal characterized ac swing is 1 V p-p. This makes the differential input 2 V p-p when QBBN is 180 degrees out of phase from QBBP.	Circuit A
16	QBBP	Q Channel Baseband Positive Input. Input should be dc biased to approximately 1.2 V. Nominal characterized ac swing is 1 V p-p. This makes the differential input 2 V p-p when QBBN is 180 degrees out of phase from QBBP.	Circuit A

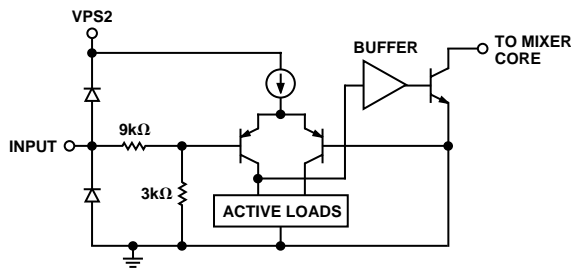

Circuit A

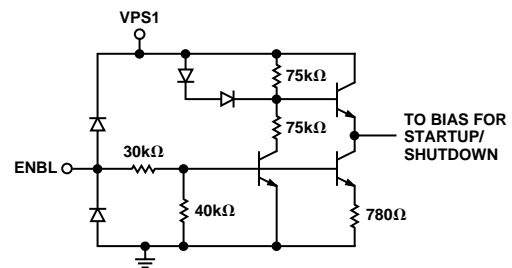

Circuit C

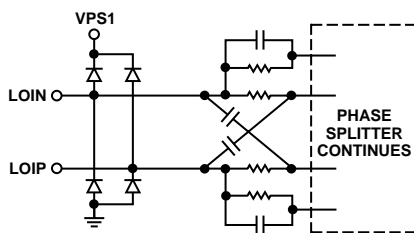

Circuit B

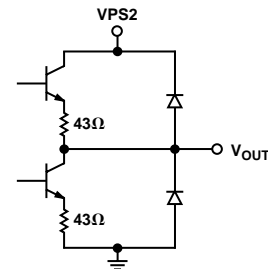

Circuit D

Figure 1. Equivalent Circuits

Typical Performance Characteristics—AD8346

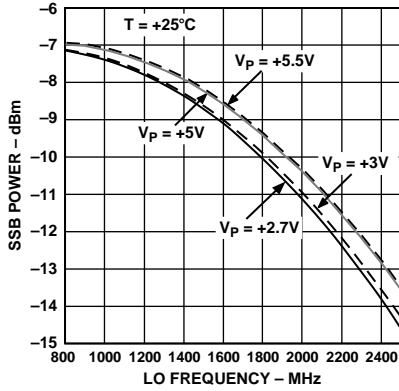

Figure 2. Single Sideband (SSB) Output Power (P_{OUT}) vs. LO frequency (F_{LO}). I and Q inputs driven in quadrature at Baseband Freq (F_{BB}) = 100 kHz with differential amplitude of 2.00 V p-p.

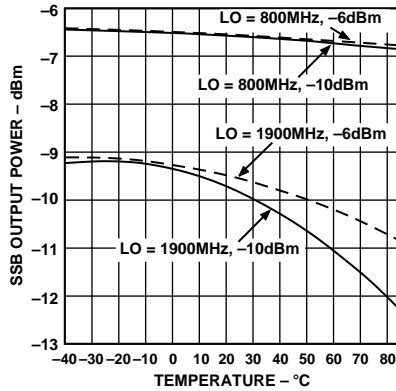

Figure 3. SSB P_{OUT} vs. Temperature. I and Q inputs driven in quadrature with differential amplitude of 2.00 V p-p at F_{BB} = 100 kHz.

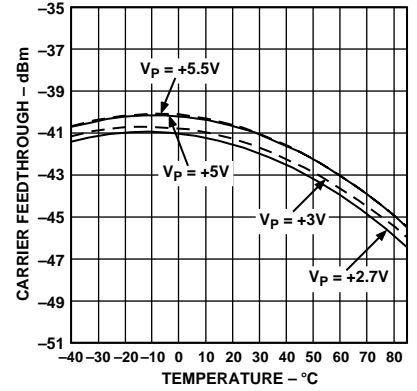

Figure 4. Carrier Feedthrough vs. Temperature. F_{LO} = 1900 MHz, LO input level = -10 dBm.

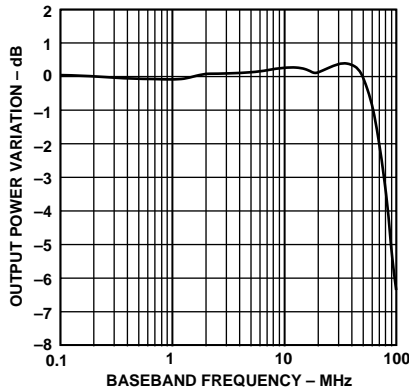

Figure 5. I and Q Input Bandwidth. F_{LO} = 1900 MHz, I or Q inputs driven with differential amplitude of 2.00 V p-p.

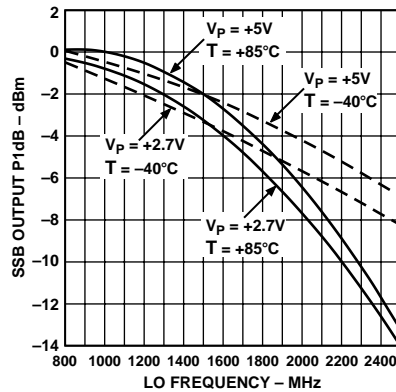

Figure 6. SSB Output 1 dB Compression Point (OP 1 dB) vs. F_{LO} . I and Q inputs driven in quadrature at F_{BB} = 100 kHz.

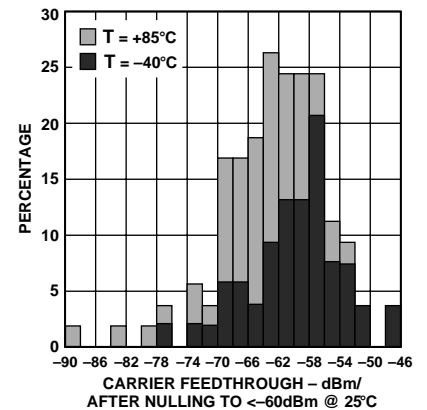

Figure 7. Histogram showing Carrier Feedthrough distributions at the temperature extremes after nulling at ambient at F_{LO} = 1900 MHz, LO input level = -10 dBm.

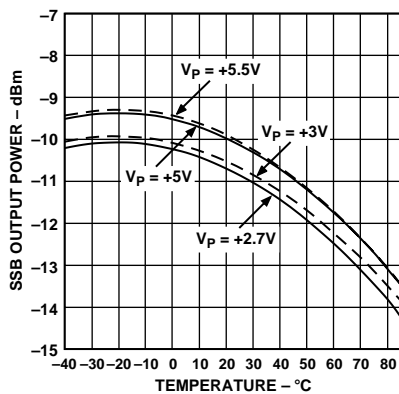

Figure 8. SSB P_{OUT} vs. Temperature. F_{LO} = 1900 MHz, I and Q inputs driven in quadrature with differential amplitude of 2.00 V p-p at F_{BB} = 100 kHz.

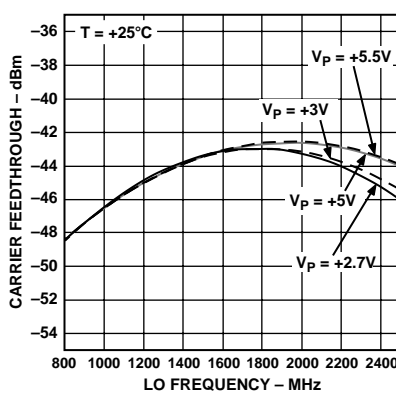

Figure 9. Carrier Feedthrough vs. F_{LO} . LO input level = -10 dBm.

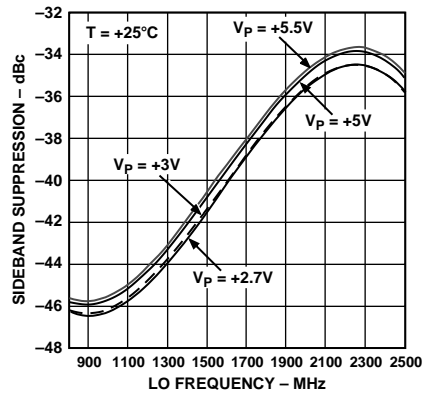

Figure 10. Sideband Suppression vs. F_{LO} . V_{POS} = 2.7 V, I and Q inputs driven in quadrature with differential amplitude of 2.00 V p-p at F_{BB} = 100 kHz.

AD8346

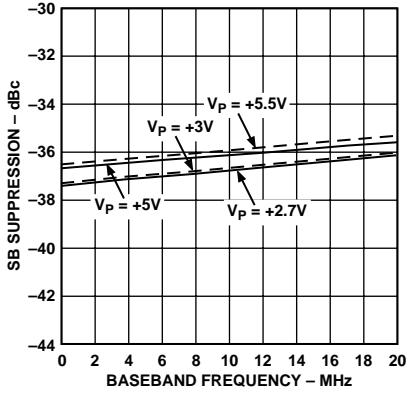

Figure 11. Sideband Suppression vs. F_{BB} . $F_{LO} = 1900$ MHz, I and Q inputs driven in quadrature with differential amplitude of 2.00 V p-p.

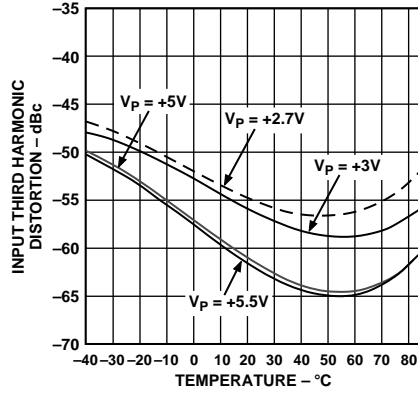

Figure 12. 3rd Harmonic Distortion vs. Temperature. $F_{LO} = 1900$ MHz, I and Q inputs driven in quadrature with differential amplitude of 2.00 V p-p at $F_{BB} = 100$ kHz.

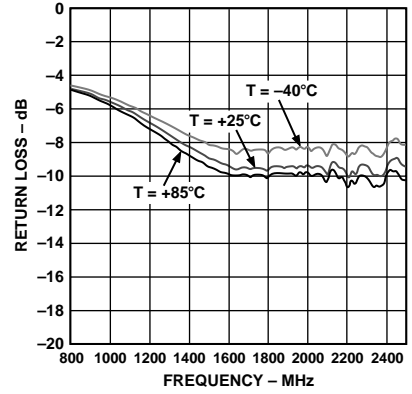

Figure 13. Return Loss of LOIN Input vs. F_{LO} . $V_{POS} = 5.0$ V, LOIP pin ac coupled to ground.

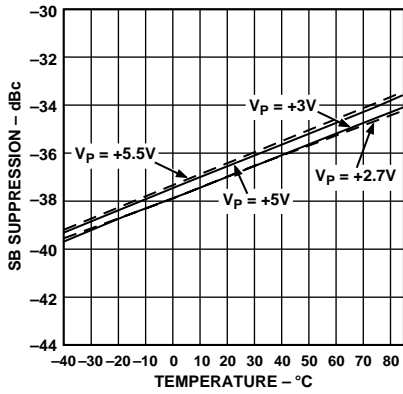

Figure 14. Sideband Suppression vs. Temperature. $F_{LO} = 1900$ MHz, I and Q inputs driven in quadrature with differential amplitude of 2.00 V p-p at $F_{BB} = 100$ kHz.

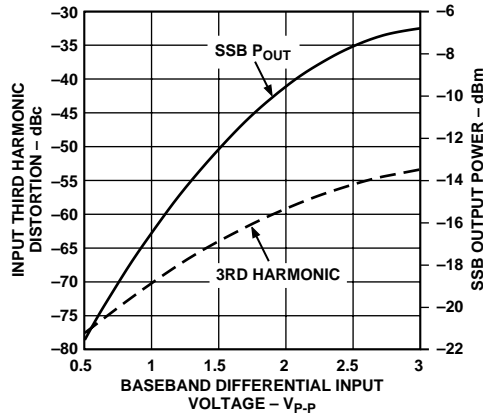

Figure 15. 3rd Harmonic Distortion and SSB Output Power vs. Baseband differential input voltage level. $F_{LO} = 1900$ MHz, I and Q inputs driven in quadrature at $F_{BB} = 100$ kHz.

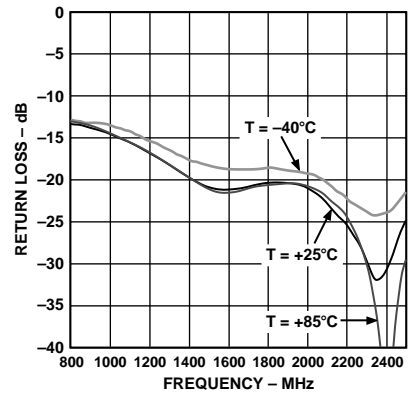

Figure 16. Return Loss of V_{OUT} Output vs. F_{LO} . $V_{POS} = 2.7$ V.

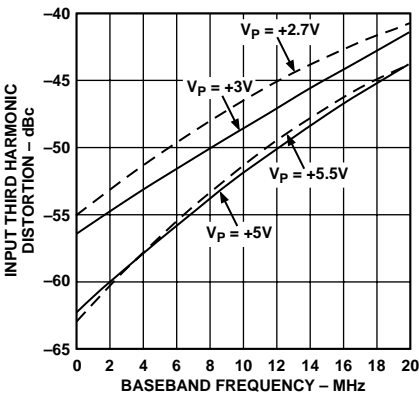

Figure 17. 3rd Harmonic Distortion vs. F_{BB} . $F_{LO} = 1900$ MHz, I and Q inputs driven in quadrature with differential amplitude of 2.00 V p-p.

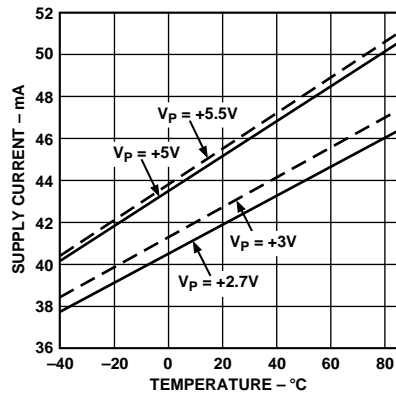

Figure 18. Power Supply Current vs. Temperature

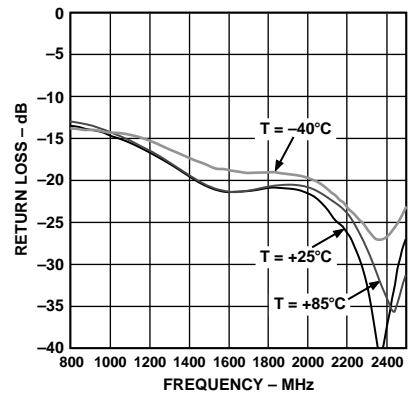

Figure 19. Return Loss of V_{OUT} Output vs. F_{LO} . $V_{POS} = 5.0$ V.

CIRCUIT DESCRIPTION

OVERVIEW

The AD8346 can be divided into the following sections: Local Oscillator (LO) Interface, Mixer, Voltage-to-Current (V-to-I) Converter, Differential-to-Single-ended (D-to-S) Converter, and Bias. A detailed block diagram of the part is shown in Figure 20.

The LO Interface generates two LO signals, with 90 degrees of phase difference between them, to drive two mixers in quadrature. Baseband voltage signals are converted into current form in the V-to-I converters, feeding into two mixers. The output of the mixers are combined to feed the D-to-S converter which provides the 50 Ω output interface. Bias currents to each section are controlled by the Enable (ENBL) signal. Detailed description of each section follows.

LO Interface

The differential LO inputs allow the user to drive the LO differentially in order to achieve maximum performance. The LO can be driven single-endedly but the LO feedthrough performance will be degraded, especially towards the higher end of the frequency range. The LO Interface consists of interleaved stages of polyphase network phase-splitters and buffer amplifiers. The phase-splitter contains resistors and capacitors connected in a circular manner to split the LO signal into I and Q paths in precise quadrature with each other. The signal on each path goes through a buffer amplifier to make up for the loss and high frequency roll-off. The two signals then go through another polyphase network to enhance the quadrature accuracy. The broad operating frequency range of 0.8 GHz to 2.5 GHz is achieved by staggering the RC time constants in each stage of

the phase-splitters. The outputs of the second phase-splitter are fed into the driver amplifiers for the mixers' LO inputs.

V-to-I Converter

Each baseband input pin is connected to an op amp driving an emitter follower. Feedback at the emitter maintains a current proportional to the input voltage through the transistor. This current is fed to the two mixers in differential form.

Mixers

There are two double-balanced mixers, one for the In-Phase Channel (I-channel) and one for the Quadrature Channel (Q-channel). Each mixer uses the Gilbert-cell design with four cross-connected transistors. The bases of the transistors are driven by the LO signal of the corresponding channel. The output currents from the two mixers are summed together in two resistors in series with two coupled on-chip inductors. The signal developed across the R-L loads are sent to the D-to-S stage.

Differential-to-Single-Ended Converter

The differential-to-single-ended converter consists of two emitter followers driving a totem-pole output stage. Output impedance is established by the emitter resistors in the output transistors. The output of this stage is connected to the output (VOUT) pin.

Bias

A bandgap reference circuit based on the ΔV_{BE} principle generates the Proportional-To-Absolute-Temperature (PTAT) currents used by the different sections as references. The bandgap voltage is also used to generate a temperature-stable current in the V-to-I converters to produce a temperature independent slew rate. When the bandgap reference is disabled by pulling down the ENBL pin, all other sections are shut off accordingly.

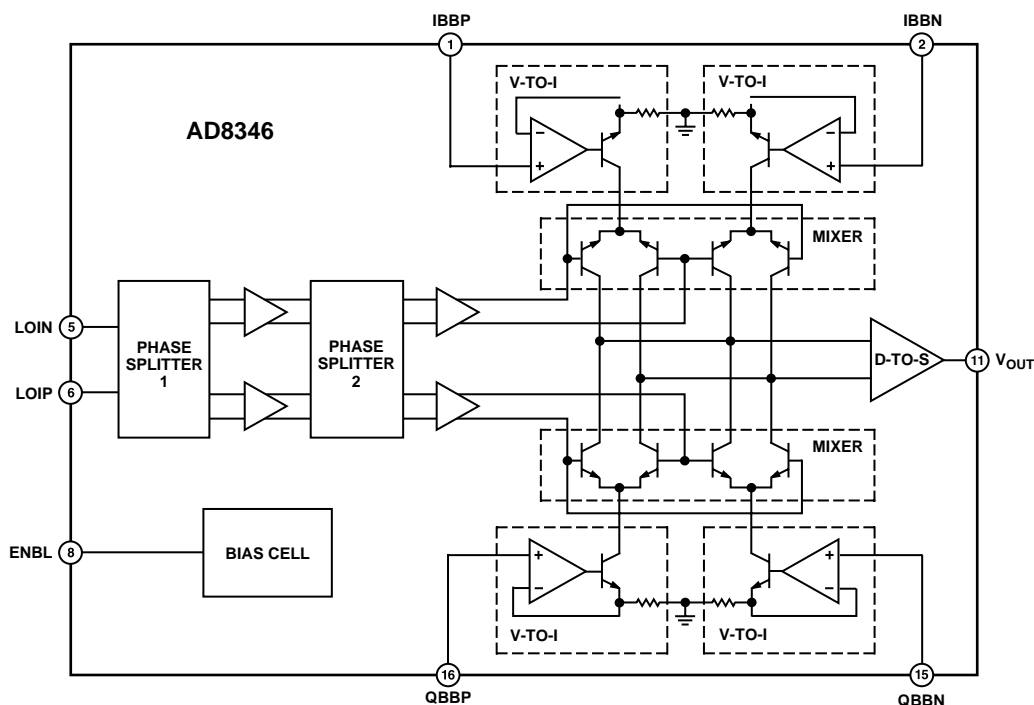

Figure 20. Detailed Block Diagram

AD8346

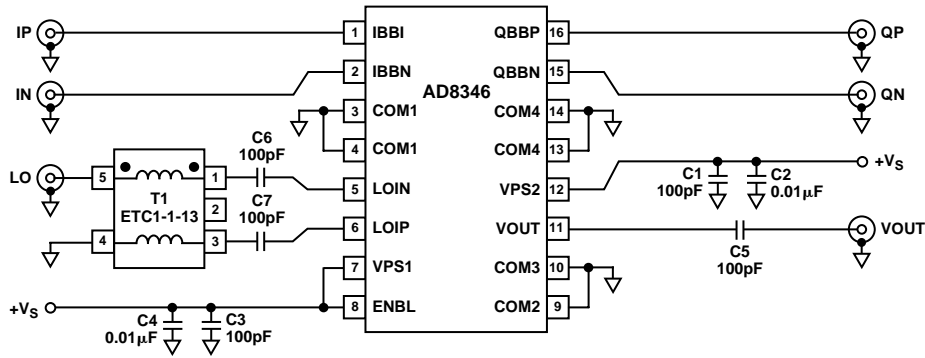

Figure 21. Basic Connections

Basic Connections

The basic connections for operating the AD8346 are shown in Figure 21. A single power supply of between 2.7 V and 5.5 V is applied to pins VPS1 and VPS2. A pair of ESD protection diodes are connected internally between VPS1 and VPS2 so these must be tied to the same potential. Both pins should be individually decoupled using 100 pF and 0.01 μ F capacitors, located as close as possible to the device. For normal operation, the enable pin, ENBL, must be pulled high. The turn-on threshold for ENBL is 2 V. To put the device in its power-down mode, ENBL must be pulled below 0.5 V. Pins COM1 to COM4 should all be tied to a low impedance ground plane.

The I and Q ports should be driven differentially. This is convenient as most modern high speed DACs have differential outputs. For optimal performance, the drive signal should be a 2 V p-p (differential) signal with a bias level of 1.2 V, that is, each input swings from 0.7 V to 1.7 V. The I and Q inputs have input impedances of 12 k Ω . By dc coupling the DAC to the AD8346 and applying small offset voltages, the LO feedthrough can be reduced to well below its nominal value of -42 dBm (see Figure 7).

LO Drive

The return loss of the LO port is shown in Figure 13. No additional matching circuitry is required to drive this port from a 50 Ω source. For maximum LO suppression at the output, a differential LO drive is recommended. In Figure 21, this is achieved using a balun (M/A-COM Part Number ETC1-1-13). The output of the balun, is ac coupled to the LO inputs which have a bias level about 800 mV below supply. An LO drive level of between -6 dBm and -12 dBm is required. For optimal performance, a drive level of -10 dBm is recommended although a level of -6 dBm will result in more stable temperature performance (see Figure 3). Higher levels will degrade linearity while lower levels will tend to increase the noise floor.

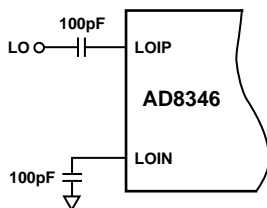

Figure 22. Single-Ended LO Drive

The LO terminal can be driven single-ended as shown in Figure 22 at the expense of slightly higher LO feedthrough. LOIN is ac coupled to ground using a capacitor and LOIP is driven through a coupling capacitor from a (single-ended) 50 Ω source (this scheme could also be reversed with LOIP being ac-coupled to ground).

RF Output

The RF output is designed to drive a 50 Ω load but must be ac coupled as shown in Figure 21. If the I and Q inputs are driven in quadrature by 2 V p-p signals, the resulting output power will be around -10 dBm (see Figure 2 for variation in output power over frequency).

Interface to AD9761 TxDAC[®]

Figure 23 shows a dc coupled current output DAC interface. The use of dual integrated DACs such as the AD9761 with specified ± 0.02 dB and ± 0.004 dB gain and offset matching characteristics ensures minimum error contribution (over temperature) from this portion of the signal chain. The use of a precision thin-film resistor network sets the bias levels precisely, to prevent the introduction of offset errors, which will increase LO feedthrough. For instance, selecting resistor networks with 0.1% ratio matching characteristics will maintain 0.03 dB gain and offset matching performance.

Using resistive division, the dc bias level at the I and Q inputs to the AD8346 is set to approximately 1.2 V. The four current outputs of the DAC each delivers a full-scale current of 10 mA, giving a voltage swing of 0 V to 1 V (at the DAC output). This results in a 0.5 V p-p swing at the I and Q inputs of the AD8346 (resulting in a 1 V p-p differential swing).

Note that the ratio matching characteristics of the resistive network, as opposed to its absolute accuracy, is critical in preserving the gain and offset balance between the I and Q signal path.

By applying small dc offsets to the I and Q signals from the DAC, the LO suppression can be reduced from its nominal value of -42 dBm to as low as -60 dBm while holding to approximately -50 dBm over temperature (see Figure 7 for a plot of LO feedthrough over temperature for an offset compensated circuit.)

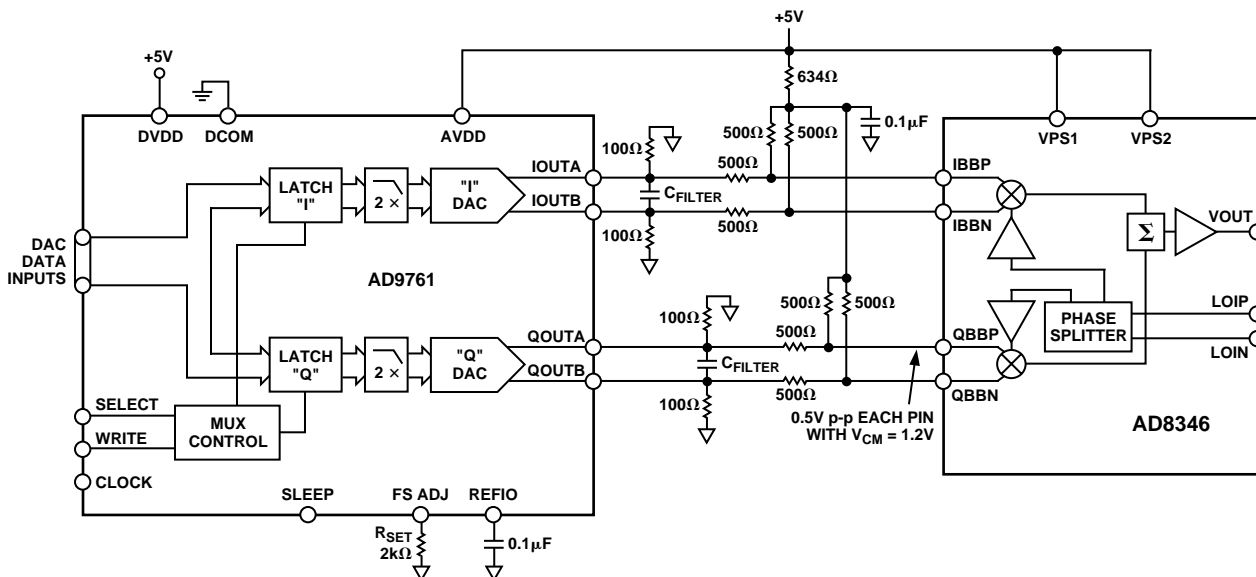

Figure 23. AD8346 Interface to AD9761 TxDAC

AC Coupled Interface

An ac coupled interface can also be implemented. This is shown in Figure 24. This has the advantage that there is almost no voltage loss due to the biasing network, allowing the AD8346 inputs to be driven by the full 2 V p-p differential signal from the AD9761 (each of the DAC's four outputs delivering 1 V p-p).

As in the dc coupled case, the bias levels on the I and Q inputs should be set to as precise a level as possible, relative to each other. This prevents the introduction of additional input offset voltages. In the example shown, the bias level on each input is set to approximately 1.2 V. The 2.43 kΩ resistors should have a ratio tolerance of 0.1% or better.

The network shown has a high-pass corner frequency of approximately 14.3 kHz (note that the 12 kΩ input impedance of the AD8346 has been factored into this calculation). Increasing the resistors in the network or increasing the coupling capacitance will reduce the corner frequency further.

Note that the LO suppression can be manually optimized by replacing a portion of the four “top” 2.43 kΩ resistors with potentiometers. In this case, the “bottom” four resistors in the biasing network would no longer need to be precision devices.

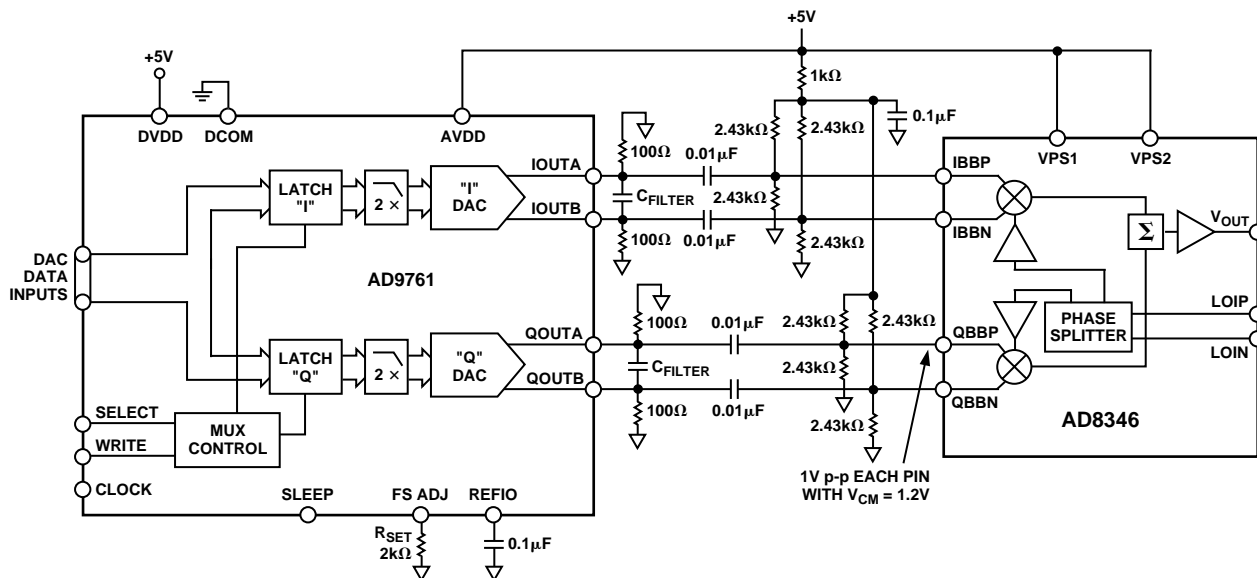

Figure 24. AC-Coupled DAC Interface

AD8346

EVALUATION BOARD

The schematic of the AD8346 evaluation board is shown in Figure 25. This is a 4-layer FR4 board, the two center layers being used as ground planes and the top and bottom layers being used for signal and power respectively. The layout and silkscreen of the top (signal) layer is shown in Figure 26. The circuit closely follows the basic connections circuit shown in Figure 21. For normal operation the board's only jumper should be in place (connecting ENBL to the supply). If the jumper is

removed, ENBL will be pulled to ground by a 10 kΩ resistor, putting the device into its power-down mode.

All connectors are SMA-type. The I and Q inputs are dc coupled to allow direct connection to a dual DAC with differential outputs. The local oscillator input is driven through a balun (M/A-COM Part Number. ETC1-1-13). To implement a single-ended drive, remove the balun and replace it with two surface mount 0 Ω resistors (i.e., from Pin 4 to 3 and Pin 1 to 5 of the balun).

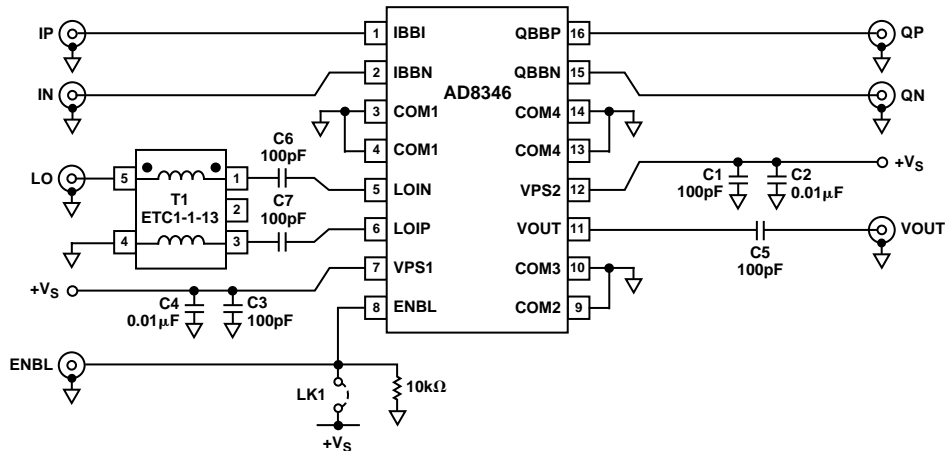

Figure 25. Evaluation Board Schematic

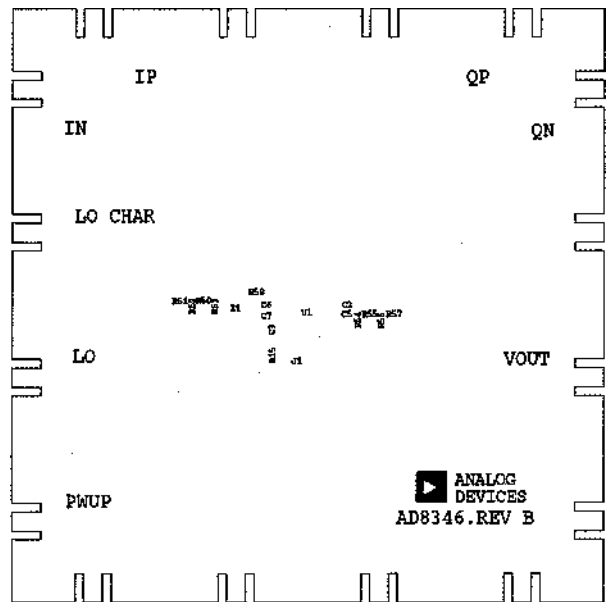
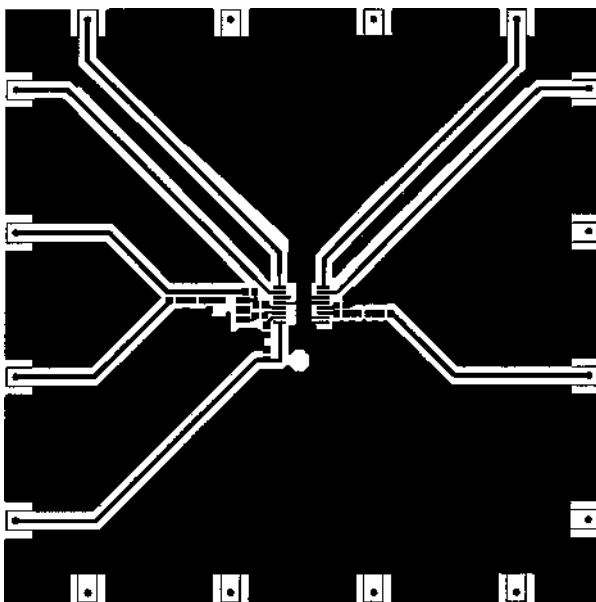

Figure 26. Layout and Silkscreen of Evaluation Board Signal Layer

CHARACTERIZATION SETUPS

SSB Setup

Two main setups were used to characterize this product. These setups are shown below in Figures 27 and 29. Figure 27 shows the setup used to evaluate the product as a Single Sideband modulator. The AD8346 Motherboard had circuitry that converted the single-ended I and Q inputs from the arbitrary function generator to differential inputs with a dc bias of approximately 1.2 V. In addition, the Motherboard also provided connections for power supply routing. The HP34970A and its associated plug-in 34901 were used to monitor power supply currents and voltages being supplied to the AD8346 Evaluation Board (a full schematic of the AD8346 Evaluation Board can be found in Figure 25). The 2 HP34907 plug-ins were used to provide additional miscellaneous dc and control signals to the Motherboard. The LO was driven by an RF signal generator (through the balun on the evaluation board to present a differential LO signal to the device) and the output was measured with a spectrum analyzer. With the I channel driven with a sine wave and the Q channel driven with a cosine wave, the lower sideband output. The typical SSB output spectrum is shown below in Figure 28.

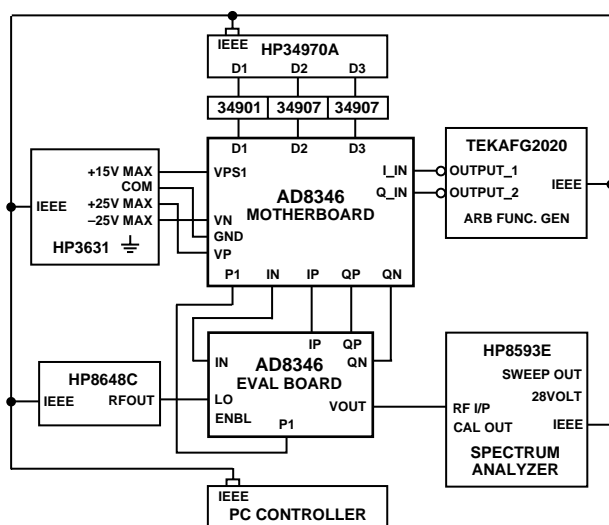

Figure 27. Evaluation Board SSB Test Setup

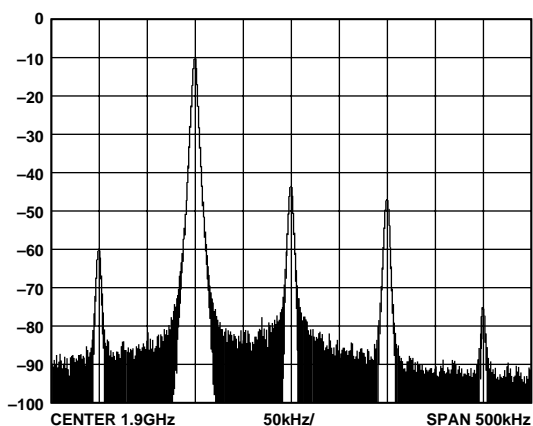

Figure 28. Typical SSB Output Spectrum

CDMA Setup

For evaluating the AD8346 with CDMA waveforms the setup shown in Figure 29 was used. This is essentially the same as that used for the single sideband characterization except the AFG2020 was replaced with the AWG2021 for providing the I and Q input signals, and the spectrum analyzer used to monitor the output was changed to an FSEA30 Rohde-Schwarz analyzer with vector demodulation capability. The I/Q input signals for these measurements were IS95 baseband signals generated with Tektronix I/Q SIM software and downloaded to the AWG2021.

For measuring ACPR the I/Q input signals used were generated with Pilot (Walsh Code 00), Sync (WC 32), Paging (WC 01), and 6 Traffic (WC 08, 09, 10, 11, 12, 13) channels active. The I/Q SIM software was set for 32x oversampling and was using a BS equifilter. Figure 30 shows the typical output spectrum for this configuration. The ACPR was measured 885 kHz away from the carrier frequency.

For performing EVM, Rho, phase, and amplitude balance measurements the I/Q input signals used were generated with only the Pilot Channel (Walsh Code 00) active. The I/Q SIM software was set for 32x oversampling and was using a CDMA equifilter.

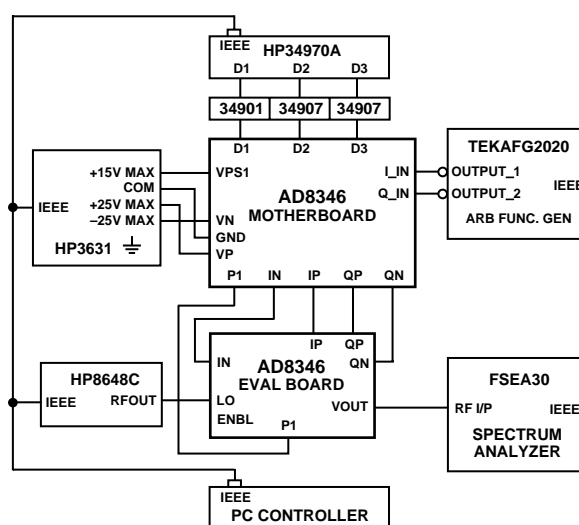

Figure 29. Evaluation Board CDMA Test Setup

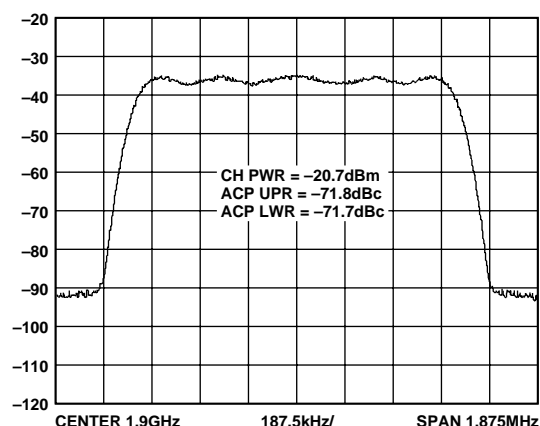

Figure 30. Typical CDMA Output Spectrum

OUTLINE DIMENSIONS

Dimensions shown in inches and (mm).

**16-Lead TSSOP
(RU-16)**

